

# Electrical Measuring Instruments



# Index

Contents:	Page
<b>Measuring Centres</b>	
MC 320 – Energy meter, MC 330 – Multimeter	3
MC 760/UMC 760 – Network Analyzer, MC 750/UMC 750 - Network Recorder	5
MC 740 – Multifunction Meter	7
MC 744 – Multifunction Meter, MC 754 – Network Recorder, MC 764 – Network Analyzer	9
MC 660/MC 666 – Network Analyzer for Rail Mounting	12
MC 650/MC 656 – Network Recorder for Rail Mounting	13
MC 640/MC 646 – Multifunction Meter for Rail Mounting	14
<b>Measuring Transducers</b>	
MT 5x0/UMT 5x0 Measuring Transducers	15
MT 560/UMT 560 – Transducer & Analyser	17
MT 550/UMT 550 – Transducer & Recorder	18
MT 540/UMT 540 – Multifunction Transducer	18
RD 500 – Remote Display for Measuring Transducers MT 5x0/UMT 5x0	19
MT 510/UMT 510 - Power Transducer	20
MT 511/UMT 511 - Power Transducer & Recorder	21
MT 516/UMT 516 - Voltage Transducer	22
MT 518/UMT 518 - Current Transducer	23
MT 406 - AC Voltage self powered Transducers	24
MT 408 - AC Current self powered Transducers	25
MT 416 - Programmable AC Voltage Transducers	26
MT 418 - Programmable AC Current Transducers	27
MT 440 - Multifunctional Transducers	28
MT 4xx - Measuring Transducers	29
MIBOX - Communicators	30
MIQEN	32
MISMART	34
<b>Communication Adapters</b>	
MI 480 – GSM Device for remote control	36
MI 485 – RS 232 / RS 485 Interface	38
MI 486, MI 488 – Interface TCP / IP	39
<b>Digital Meters</b>	
Digital Meters with LED Display	40
<b>Synchronization Meters</b>	
	42
<b>Energy Meters with Power Display</b>	
	43
<b>Hour Meters &amp; Pulse Countres</b>	
Hour Meters HK 30 - HK 49	44
Pulse Counters SI 63, SI 64, SI 65, MC 703, MC 723	45

# Index

## Analogue Meters

Active or Reactive Power Meters	46
Power Factor Meters	47
Pointer Frequency Meters	48
Reed Frequency Meters	49
Meter with Limit Contact	50
Meters for DC Voltage or Current with Moving Coil	51
TAP Position Meters with Moving Coil	52
Meters for AC Voltage or Current with Moving Coil and a Rectifier	54
Meters for DC Voltage or Current with Moving Coil	55
Meters for AC Voltage or Current with Moving Iron	56
Bimetal Maximum Current Meters	58
Combined Bimetal Maximum Current Meters	59
Phase Sequence Indicator and Temperature Meters	60

## Portable Meters

MI 7033 Analogue Multiwattmeter	61
Multimeters	62
Educational Programme	63
MI 7022 Digital Temperature Meter	64

## Equipment and Accessories

Shunts	65
Current Measuring Transformers	66

## Special Demands

67

## General Explanations

68

## Dimensional Drawings

72

## Conection Diagrams

87

## Instruments Conformity to Standards

105

NOTE:  
Data about ENERGY METERS can be found in separate brochure.

# Measuring Centres

## MC 320 - ENERGY METER, MC 330 - MULTIMETER



### USE

For electricity distribution and energy production companies, utilities, dwellings, energy management solution providers, industry, business buildings, designers of small power stations, panel builders, etc.

### Main features are:

- Measurements of instantaneous values for more than 60 quantities (U, I, P, Q, S, PF, PA, f, j, THD, MD ...)
- 4 Energy counters
- Accuracy class U, I, P 0.5 (Active energy Class 1, optional Class 0.5S)
- Large frequency range from 16 2/3 Hz to 400 Hz
- Up to 2 tariff inputs (option)
- Up to 2 pulse or relay outputs (option)
- AC or Universal (option) power supply
- Graphical LCD; 128 x 64 dots with illumination
- Automatic range of nominal current (max. 12.5 A) and voltage (option)
- User-adjustable display of measurements
- Multilingual support (13 languages)
- RS 485 or RS232 communication up to 115,200 bit/s (option)
- MODBUS communication protocol supported
- User-friendly PC MiQen software for setting via RS485 or RS232 communication

### Measurands

- RMS values of currents and voltages (only MC330)
- Measurements of active, reactive, apparent power and power factor (only MC330)
- Measurements of energy in all 4 quadrants
- Average values of measurands per interval (only MC330)

225.9<sub>2</sub> V U1  
144.2<sub>9</sub> mA I1  
23.7<sub>3</sub> W P1

42.7<sub>3</sub> W P  
39.2<sub>6</sub> var<sup>+</sup> Q  
59.0<sub>3</sub> VA S

MD values  
P+ = 143.2<sub>0</sub> kW  
P+ = 184.5<sub>0</sub> kW

3.1<sub>2</sub> % U1%  
2.9<sub>2</sub> % U2%  
3.4<sub>3</sub> % U3%

### Input / output modules

The modules are available with double inputs/outputs. Each module has three terminals. The meter is available with-out, with one or with two modules. The following modules are available:

- Output module (relay version MC330 only) 2 outputs
- Tariff input 2 inputs

Output module is available as:

- Opto output according EN62053-31:2001 (27 V, 27 mA)
- Relay output in MC330 can be used for pulse output or alarm output (40 V, 1 A).

### Communication

Option is communication module for reading measured values and instrument setting. Available is RS232 or RS485 communication type module. Communication is galvanic separated from other circuits. For setting we suggest using MIQEN software.

### Supply

Standard is AC power supply enables connection of the meter to AC voltage (57.7 & 63.5 / 100 & 110 / 230 / 400). Option is a universal power supply enables connection of the meter to DC (20–300 V) or AC voltage (48–276 V / 50 Hz).

### MiQEN

MiQen software is intended for supervision of the meter on PC. It enables setting meter parameters that are transferred into the instrument via communication (option). Multilingual software functions on Windows 98, 2000, NT, XP operating systems.

# Measuring Centres

## MULTIMETER MC 330, ENERGY METER MC 320

### Accuracy

Accuracy is presented as percentage from nominal value of the measurand except when it is stated as an absolute value.

Measurand		Accuracy
Rms current (I1, I2, I3, Iavg, In, MD)		0.5
Rms phase voltage (U1, U2, U3, Uavg, MD)	25 ... 600 V	0.5
Phase-to-phase voltage (U12, U23, U31, Uavg)		0.5
Frequency (f)		10 mHz
Power factor (PF)		0.5
Phase and phase-to-phase angle ( $\varphi$ , $\varphi_{12}$ , $\varphi_{23}$ , $\varphi_{31}$ )		0.5°
Active, reactive and apparent power		0.5
Active energy	EN 62053-21	Class 1
Reactive energy	EN 62053-23	Class 2
Pulse output	EN 62053-31	Class A & B

### Inputs

Inputs signals	Current	Voltage
Nominal frequency range		50, 60 Hz
Measuring frequency range		16 - 400 Hz
Nominal value (In, Un)	1 / 5 A	75, 120, 250, 500 V <sub>L-N</sub>
Maximal value	12.5 A	600 V <sub>L-N</sub>
Consumption	< 0.1 VA	< 0.1 VA

### Power supply

Power supply	Universal	AC
Nominal voltage AC	48 - 276 V	57.7 & 63.5 / 100 & 110 / 230 / 400
Nominal frequency	40 - 65 Hz	40 - 65 Hz
Nominal voltage DC	20 - 300 V	—
Consumption	< 3 VA	< 3 VA

### Safety

Safety	Protection clas II 600 v rms, installation category II 300 v rms, installation category III Pollution degree 2 in compliance with EN 61010-1:2002
Enclosure material	PC/ABS Incombustibility-self-extinguish ability, complying with UL 94 V-0
Enclosure protection	IP 52 (IP 00 for terminals) in compliance with EN 60529:1997

### Reference conditions

Ambient temperature	-10 ... 23 ... 55 °C
Voltage input	+/- 20 % Un
Voltage input with voltage autorange	50 ... 500 V
Current input	0 ... 100 % In
Active/reactive power factor	$\cos \varphi = 1 / \sin \varphi$
Waveform	sinus

### Ambient conditions

Temperature range of operation	-10 to +55 °C
Storage temperature range	-40 to +70 °C
Average annual humidity	≤ 75 % r.h.

Dimensional drawings on page 82.  
Connection diagrams on pages 87.  
Software on pages 32-35.

# Measuring Centres

## MC 760/UMC 760 - NETWORK ANALYZER, MC 750/UMC 750 - NETWORK RECORDER

### USE

The MC 760/UMC 760 network analyzer is used for permanent analysis of electric voltage quality in compliance with the EN 50160 standard. Records are stored in the internal memory for the period of the last 3 years. Moreover, more than 170,000 deviations of the measured quantities from the standard values are stored, which enables finding of eventual reasons for the problems on network. Optional limits and required quality in a monitored period can be defined for each monitored characteristic.

The meter measures and records the following characteristics:

- Frequency deviations
- Voltage deviations
- Voltage dips
- Voltage interruptions
- Voltage unbalances
- Over-voltages
- Fast voltage changes
- Flicker intensity
- THD
- Harmonics

### Main features are:

- Evaluation of the quality of electric voltage in compliance with EN 50160 (only MC 760/UMC 760)
- Measurements of instantaneous values of more than 140 quantities (U, I, P, Q, S, PF, PA, f,  $\varphi$ , THD, MD, energy, energy price by tariffs, etc.).
- Accuracy class 0.5
- Harmonic analysis of phase, phase-to-phase voltages and currents up to the 63<sup>th</sup> harmonic (only MC 760/UMC 760)
- Recording up to 32 measured quantities and alarms in the internal memory (8 MB flash - MC 760/UMC 760, 4 MB flash - MC 750/ 750)
- Measurements of 40 minimal and maximal values in different time periods
- 32 adjustable alarms
- Wide frequency range from 16 Hz to 400 Hz
- RS 232/RS 485 communication up to 115,200 bit/s or Ethernet communication
- MODBUS and DNP3 communication protocol
- MMC memory card for data transmission, setting and upgrading
- Up to 4 inputs or outputs (analogue outputs, pulse outputs, alarm outputs, tariff inputs, pulse input, analogue input, bistable alarm, digital input)
- Universal or AC power supply
- Graphical LCD 128 x 64 dots with illumination
- Automatic range of nominal current up to 5 A and nominal voltage up to 500 V
- Adjustable tariff clock, display of electric energy consumption in optional currency
- Multilingual support
- User-friendly PC MiQen software

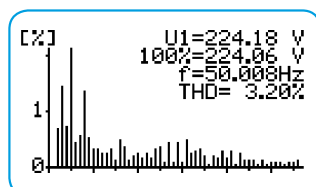
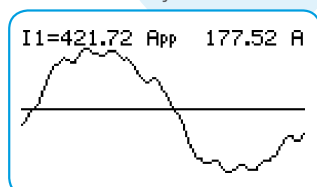

E1	<b>332.55</b>	EUR
E2	<b>54.74</b>	EUR
E3	<b>2.79</b>	EUR
E4	<b>21.58</b>	EUR
<b>Σ</b>	<b>411.66</b>	EUR

Active Power	
Max	<b>+381.23 kW</b>
	<b>132.47 kW</b> <sup>P</sup>
Min	<b>+13.55 kW</b>

# Measuring Centres

## MC 760/UMC 760 - NETWORK ANALYZER, MC 750/UMC 750 - NETWORK RECORDER

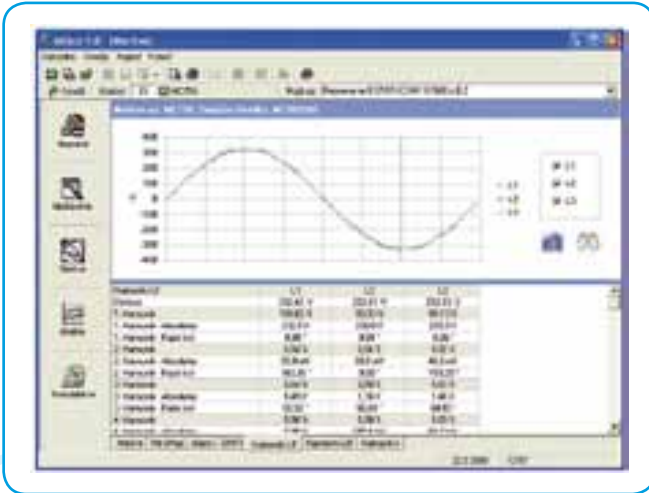

### Handling the costs

A special meter function is cost evaluation of energy (active, reactive and total) by tariffs. The meter itself enables tracing the energy costs in optional currency. The meter calculates consumption in optional currency by means of the adjustable tariff clock and electric energy price.

### Input / output modules

The modules are available with double inputs/outputs using a common connection contact (except a bistable alarm module - 1 output, 3 terminals). The meter is available without, with one or with two modules. The following modules are available:

- Alarm output 2 outputs
- Analogue output 2 x 20 mA outputs
- Pulse output 2 outputs
- Tariff input 2 inputs
- Bistable alarm output 1 output
- Additional communication port (COM2)
- Pulse input
- Analogue Input
- Digital input

Dimensional drawings on page 82.  
Connection diagrams on pages 88,89.  
Software on pages 32-35.

# Measuring Centres

## MC 740/UMC 740 - MULTIFUNCTION METER



### USE

The MC 740 multifunction meter is used for monitoring and measuring electrical quantities of a three-phase electric-energy distribution system. The meter is provided with 32 program adjustable alarms, up to four inputs or outputs and communication. The meter can be set and measurements can be checked with the RS 232/RS 485 or Ethernet communication. The meter also functions as an electricity meter, with the additional function of cost management by tariffs. A tariff input or a tariff clock can be set. At tariff clock setting, four periods and four work groups as well as electric energy price for each period and a work group (16 different price periods) are available. Additionally, 20 places are available for setting holidays or days when special tariff rules are valid. As an electricity meter it records energy in all four quadrants in four tariffs.

### Main features are:

- Measurement of instantaneous values of more than 130 quantities (U, I, P, Q, S, PF, PA, f, φ, MD, energy, energy price by tariffs, etc.).
- Accuracy class 0.5
- Measurement of 40 minimum and maximum values in different time periods
- 32 adjustable alarms
- Wide frequency range from 16 Hz to 400 Hz
- RS 232/RS 485 communication up to 115,200 bit/s or Ethernet communication
- MODBUS and DNP3 communication protocols
- MMC memory card for setting and upgrading the meter
- Up to 4 inputs or outputs (analogue outputs, pulse outputs, alarm outputs, tariff inputs, pulse input, analogue input, bistable alarm, digital input)
- Universal or AC power supply
- Graphic LCD 128 x 64 dots with illumination
- Automatic range of nominal current up to 5 A and nominal voltage up to 500 V
- Adjustable tariff clock, display of electric energy consumption in optional currency
- Multilingual support
- User-friendly PC MiGen software

3.12 U1%  
%THD  
2.92 U2%  
%THD  
3.43 U3%  
%THD

MD values  
P+= 143.20 kW  
MD at 18. 1. 8:19  
P+= 184.50 kW

MMC card  
MMC info  
Save data  
Save settings  
Load settings  
Software update  
↔ Main menu

1 ■ 3325.45 kWh  
T1 > 3282.73 kWh  
T2 15.25 kWh  
T3 6.44 kWh  
T4 21.01 kWh

# Measuring Centres

## MC 740/UMC 740 - MULTIFUNCTION METER

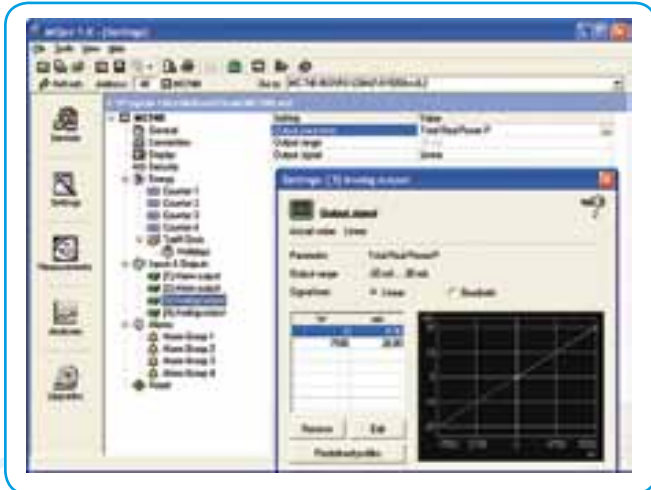

### Handling the costs

A special meter function is cost evaluation of energy (active, reactive and total) by tariffs. The meter itself enables tracing the energy costs in optional currency. The meter calculates consumption in optional currency by means of the adjustable tariff clock and electric energy price.

### Input / output modules

The modules are available with double inputs/outputs using a common connection contact (except a bistable alarm module - 1 output, 3 terminals). The meter is available without, with one or with two modules. The following modules are available:

- Alarm output 2 outputs
- Analogue output 2 x 20 mA outputs
- Pulse output 2 outputs
- Tariff input 2 inputs
- Bistable alarm output 1 output
- Pulse input
- Analogue Input
- Digital input

Dimensional drawings on page 82.  
Connection diagrams on pages 88,89.  
Software on pages 32-35.

# Measuring Centres

## MC 764 - NETWORK ANALYZER, MC 754 - NETWORK RECORDER, MC 744 - MULTIFUNCTION METER

### DESCRIPTION

The meter is intended for measuring, analysing and monitoring single-phase or three-phase electrical power network. The meter measures RMS value according to the principle of fast sampling of voltage and current signals. A built-in microprocessor calculates measurands (voltage, current, frequency, energy, power, power factor, THD phase angles, etc.) from the measured signals.

### USE

Meters from MC7x4 series are designed for environments where beside measurement of three-phase electrical power network additional analogue or digital measurements/controls must be made without additional hardware (PLC, OPLC, ...). Meters are housed in enclosure 144mm x 144mm.



### Features:

- Alarm or relay outputs
- Digital inputs/outputs
- Analogue outputs/inputs
- Evaluation of the electricity supply quality in compliance with EN 50160 (only MC 764)
- Measurements of instantaneous values of more than 140 quantities (U, I, P, Q, S, PF, PA, f, , THD, MD, energy, energy cost by tariffs, etc.)
- Accuracy class 0.5 (optional 0.2)
- Harmonic analysis of phase, phase-to-phase voltages and currents up to the 63rd harmonic (only MC 764)
- Recording up to 32 measurands and 32 alarms in the internal memory (only MC 754/764)
- Measurements of 40 minimal and maximal values in different time periods
- 32 adjustable alarms
- Frequency range from 16 Hz to 400 Hz
- RS 232/RS 485 communication up to 115,200 bit/s or Ethernet & USB communication
- MODBUS and DNP3 communication protocol
- MMC/SD card for data transmission, setting and upgrading
- Up to 4 inputs or outputs (analogue outputs, pulse outputs, alarm outputs, tariff inputs, pulse input, analogue input, bistable alarm, digital input)
- Additional I/O modules with up to 16 digital inputs or outputs, or up to 8 analogue outputs
- Additional communication port (COM2)
- Universal power supply
- Graphical LCD; 128 x 64 dots with illumination
- Automatic range of nominal current and voltage (max. 12.5 A and 750 V)
- Adjustable tariff clock, display of electric energy consumption in optional currency
- Multilingual support
- User-friendly PC MiQen software
- Additional analogue or digital measurements/controls can be made without additional hardware (PLC, OPLC, etc.)

Dimensional drawings on page 82.  
Connection diagrams on pages 90.  
Software on pages 32-35.

# Measuring Centres

## FAMILY OF MC 7x0/UMC 7x0, MC 7x4

### - COMPARISON AND COMMON CHARACTERISTICS

INSTRUMENT						
DIN 96	MC 744	MC 754	MC 764	MC 740	MC 750	MC 760
ANSI 100	-	-	-	UMC 740	UMC 750	UMC 760
<b>Hardware configuration</b>						
Backlight LCD 128x64	•	•	•	•	•	•
Keyboard keys	5	5	5	5	5	5
LED indicator (SD or MMC/com./alarm)	•/•/•	•/•/•	•/•/•	•/•/•	•/•/•	•/•/•
Slot for SD/MMC card	•	•	•	•	•	•
Power supply	Universal	Universal	Universal	Univ., AC	Univ., AC	Univ., AC
Energy meters	4	4	4	4	4	4
Real time clock	•	•	•	•	•	•
Internal flash memory	-	8 Mb	8 Mb	-	4 Mb	8 Mb
Auto Range Current	•	•	•	•	•	•
Auto Range Voltage	•	•	•	•	•	•
<b>Communication (COM1)</b>						
Communication ports	1	1	1	1	1	1
RS232 & RS485 / Ethernet & USB	•/•	•/•	•/•	•/•	•/•	•/•
Modbus and DNP3	•	•	•	•	•	•
<b>Inputs and Outputs (I/O)</b>						
I/O Slot 1 (2PO / 2PI / 2TI / 2AL / 2AI / 2PI / 1BA / 2AN / 2DI / COM2)	○/○/○/○/○/ ○/○/○/○/○-	○/○/○/○/○/ ○/○/○/○/○-	○/○/○/○/○/ ○/○/○/○/○-	○/○/○/○/○/ ○/○/○/○/○-	○/○/○/○/○/ ○/○/○/○/○-	○/○/○/○/○/ ○/○/○/○/○-
I/O Slot 2 (2PO / 2PI / 2TI / 2AL / 2AI / 2PI / 1BA / 2AN / 2DI / COM2*)	○/-/○/○/○/ ○/○/○/○/○	○/-/○/○/○/ ○/○/○/○/○	○/-/○/○/○/ ○/○/○/○/○	○/-/○/○/○/-/○/ ○/○/○/○/○	○/-/○/○/○/-/○/ ○/○/○/○/○	○/-/○/○/○/-/○/ ○/○/○/○/○
I/O Slot 3 (8AL / 8DO / 8DI / 4AN / 4AIR / 4AIU / 4AI)	○/○/○/○/ ○/○/○	○/○/○/○/ ○/○/○	○/○/○/○/ ○/○/○	-	-	-
I/O Slot 4 (8AL / 8DO / 8DI / 4AN / 4AIR / 4AIU / 4AI)	○/○/○/○/ ○/○/○	○/○/○/○/ ○/○/○	○/○/○/○/ ○/○/○	-	-	-
<b>Available functions</b>						
Setup wizard	•	•	•	•	•	•
Wrong connection warning	•	•	•	•	•	•
Custom screens	•	•	•	•	•	•
Reset default settings	•	•	•	•	•	•
Programmable refresh time	•	•	•	•	•	•
MD calculation (TF, FW, SW)	•,•,•	•,•,•	•,•,•	•,•,•	•,•,•	•,•,•
Tariff clock	•	•	•	•	•	•
Cost management	•	•	•	•	•	•
Programmable alarms	32	32	32	32	32	32
Alarms recording	-	•	•	-	•	•
Measurements recording	-	•	•	-	•	•
EN 50160 analysis	-	-	•	-	-	•
PC software	MIQen	MIQen	MIQen	MIQen	MIQen	MIQen
<b>Available measurements</b>						
Actual values: U, I, P, Q, S, PF, PA, f, φ	•	•	•	•	•	•
Energy	•	•	•	•	•	•
Maximum demands	•	•	•	•	•	•
Minimum values: U, I, P, Q, S, PF, PA, f, φ	•	•	•	•	•	•
Maximum values: U, I, P, Q, S, PF, PA, f, φ	•	•	•	•	•	•
THD (actual)	•	•	•	•	•	•
Harmonics	Up to 31st	Up to 31st	Up to 63rd	Up to 31st	Up to 31st	Up to 63rd

\*Additional COM2

# Measuring Centres

## FAMILY OF MC 7x0/UMC 7x0, MC 7x4

### - COMPARISON AND COMMON CHARACTERISTICS

#### Legend:

- - feature not supported
- - MC has feature
- - optional function
- PO - pulse output
- PI - pulse input
- TI - tariff input
- AL - alarm output

- AN - analogue output
- AI - analogue input
- BI - bistable alarm
- DI - digital input
- TF - thermal function
- FW - fixed window
- SW - sliding window
- COM - additional communication port (COM2)

#### INPUTS

Input signals	Current	Voltage
Nominal frequency range	50–60 Hz	
Measuring frequency range	16 2/3–400 Hz	
Nominal value (I <sub>n</sub> , U <sub>n</sub> )*	5 A	500 V <sub>L-N</sub>
Maximum value (sinus curve)	12,5 A	750 V <sub>L-N</sub>
Rating	1–5 A	57,7–500 V <sub>L-N</sub>
Consumption	< 0,1 VA	< 0,1 VA

\* Automatic range

#### POWER SUPPLY

Supply	Universal	AC
Power Supply	48–276 V	57,7 / 63,5 / 100 / 110 / 230 / 400 500 V
Nominal voltage AC	40–65 Hz	40–65 Hz
Nominal frequency		
Nominal voltage DC	20–300 V	–
Consumption	< 10 VA*	< 8 VA

\* Consumption at MC 7x0 family is < 7 VA

#### ACCURACY

Measured quantity		Accuracy
Rms current (I <sub>1</sub> , I <sub>2</sub> , I <sub>3</sub> , I <sub>avg</sub> , I <sub>n</sub> )		0,5 (optional 0,2)
Rms phase voltage (U <sub>1</sub> , U <sub>2</sub> , U <sub>3</sub> , U <sub>avg</sub> )	62.5 – 750 V	0,5 (optional 0,2)
Phase-to-phase voltage (U <sub>12</sub> , U <sub>23</sub> , U <sub>31</sub> , U <sub>avg</sub> )		0.5 (optional 0,2)
Frequency (f)		0.02
Power factor (PF)		0.5
Phase and phase-to-phase angle (φ, φ <sub>12</sub> , φ <sub>23</sub> , φ <sub>31</sub> )		0.5
THD	0...400 %	0.5
Active power		0.5 (optional 0.2)
Reactive power		1.0 (optional 0.5)
Apparent power		1.0 (optional 0.5)
Active energy	EN 62053-21	Class 1 (optional 0.5S)
Reactive energy	EN 62052-23	Class 2
Real time clock		1 min./month (30 ppm)
Analogue output		+ - 0.2 mA

# Measuring Centres

## MC 660/MC 666 NETWORK ANALYZER FOR RAIL MOUNTING



### USE

The instrument is used for permanent analysis of electricity supply quality in compliance with the EN 50160 standard. A partition in the internal memory is reserved for storing reports for a period of the last seven years. The internal memory capacity enables storing of more than 170,000 variations of the measurements from the standard values, which enables finding eventual reasons for the problems in network. Limits and required quality in a monitored period can be defined for each monitored characteristic. The following characteristics are measured and recorded:

- Frequency variations
- Voltage variations
- Voltage unbalances
- Voltage dips
- Voltage interruptions
- Rapid voltage changes
- Flickers Pst & Plt
- Temporary over voltages
- THD's
- Harmonics

### FEATURES:

- Evaluation of the electricity supply quality in compliance with EN 50160
- Measurements of instantaneous values of more than 150 quantities (U, I, P, Q, S, PF, PA, f,  $\varphi$ , T HD, MD, energy, energy cost by tariffs, etc.)
- Accuracy class 0.5
- Harmonic analysis of phase, phase-to-phase voltages and currents up to the 63rd harmonic
- Recording up to 32 measurements and 32 alarms in the internal memory (8 MB flash)
- Measurements of 40 minimal and maximal values in different time periods
- 32 adjustable alarms
- Frequency range from 16 Hz to 400 Hz
- RS 485 communication up to 115.200 bit/s
- MODBUS and DNP3 communication protocol
- Up to 4 (2+2) inputs or outputs (pulse outputs, alarm outputs, tariff inputs, digital inputs)
- Universal power supply 48-276V AC, 20-300V DC
- Graphical LCD; 128 x 64 dots with illumination
- Direct 65 A connection (MC 666)
- CT 5 A connection (MC 660)
- Housing for DIN rail mounting
- Adjustable tariff clock, display of electric energy consumption in optional currency
- Multilingual support
- User-friendly PC MiQen software

Dimensional drawings on page 82.  
Connection diagrams on pages 91, 92.  
Software on pages 32-35.

# Measuring Centres

## MC 650/MC 656 NETWORK RECORDER FOR RAIL MOUNTING

### USE

The instrument is used for monitoring, measuring and recording measurements of electric quantities of electrical power distribution system. Up to 32 measurements and up to 32 alarms are recorded in the internal memory. The memory is separated into two sections for measurements (A and B) and one section for recording alarms. The memory division is defined by the user via communication.



### FEATURES:

- Measurements of instantaneous values of more than 150 quantities (U, I, P, Q, S, PF, PA, f,  $\varphi$ , THD, MD, energy, energy cost by tariffs, etc.)
- Accuracy class 0.5
- Harmonic analysis of phase, phase-to-phase voltages and currents up to the 31st harmonic
- Recording up to 32 measurements and 32 alarms in the internal memory (8 MB flash)
- Measurements of 40 minimal and maximal values in different time periods
- 32 adjustable alarms
- Frequency range from 16 Hz to 400 Hz
- RS 485 communication up to 115.200 bit/s
- MODBUS and DNP3 communication protocol
- Up to 4 (2+2) inputs or outputs (pulse outputs, alarm outputs, tariff inputs, digital inputs)
- Universal power supply 48-276 V AC, 20 - 300 V DC
- Graphical LCD; 128 x 64 dots with illumination
- Direct 65 A connection (MC 656)
- CT 5 A connection (MC 650)
- Housing for DIN rail mounting
- Adjustable tariff clock, display of electric energy consumption in optional currency
- Multilingual support
- User-friendly PC MiQen software

Dimensional drawings on page 82.  
Connection diagrams on pages 91, 92.  
Software on pages 32-35.

# Measuring Centres

## MC 640/MC 646 MULTIFUNCTION METER FOR RAIL MOUNTING



### USE

The instrument is used for monitoring and measuring electric quantities of three-phase electrical power distribution system. The meter is provided with 32 program adjustable alarms, a serial communication port, two pulse (alarm) outputs and two tariff (digital) inputs. The meter can be set and measurements can be checked with the RS485 communication. The meter also functions as an energy counter, with the additional function of cost management by tariffs. A tariff input or a tariff clock can be set. At tariff clock setting, four seasons and four day groups as well as energy cost for each period and a day group (16 different cost periods) are available. Additionally, 20 places are available for setting holidays. As an energy counter it can record energy in all four quadrants in four tariffs.

### FEATURES

- Measurements of instantaneous values of more than 150 quantities (U, I, P, Q, S, PF, PA, f,  $\varphi$ , MD, energy, energy cost by tariffs, etc.)
- Accuracy class 0.5
- Harmonic analysis of phase, phase-to-phase voltages and currents up to the 31st harmonic
- Measurements of 40 minimal and maximal values in different time periods
- 32 adjustable alarms
- Frequency range from 16 Hz to 400 Hz
- RS 485 communication up to 115,200 bit/s
- MODBUS and DNP3 communication protocol
- Up to 4 (2+2) inputs or outputs (pulse outputs, alarm outputs, tariff inputs, digital inputs)
- Universal power supply 48-276 V AC, 20-300 V DC
- Graphical LCD 128 x 64 dots with illumination
- Direct 65 A connection (MC646)
- CT 5 A connection (MC640)
- Housing for DIN rail mounting
- Adjustable tariff clock, display of electric energy consumption in optional currency
- User-adjustable display of measurements
- Multilingual support
- User-friendly PC MiQen software

Dimensional drawings on page 82.  
Connection diagrams on pages 91, 92.  
Software on pages 32-35.

# Measuring Transducers

## MT 5x0/UMT 5x0

### - Comparison and common characteristics



Main features of all MT 5x0/UMT 5x0 Measuring Transducers

- Accuracy 0.2 (IEC EN 60688), 0.1 (on communication)
- 4 I/O modules:
  - up to 4 analogue outputs
  - up to 4 analogue inputs
  - up to 4 digital inputs
  - up to 4 digital outputs
  - up to 4 pulse outputs
  - up to 2 tariff inputs
  - up to 4 alarms
  - with combination of previously listed inputs/outputs
  - watchdog relay output
- An additional COM2 serial communication module can be set instead of the 4th I/O module
- Pulse outputs can be set separately for the chosen tariff and for all tariffs together
- For an analogue output with the ranges +/- 20 mA and +/- 10 V, other ranges are set with software
- Analogue inputs support bipolar voltage (+/- 10V) or bipolar current (+/- 20mA) or two-wire temperature (PT1000; -200°C to +850°C) and resistance (up to 4 kΩ)
- 2 communication ports:
  - COM1: 3 ways of communication, always just one available: serial (RS232/485) or USB or Ethernet & USB
- Communication protocols: Modbus (115,200 b/s), DNP3
- A transducers automatically detects communication protocols (MODBUS/DNP3)
- Frequency ranges: 16 2/3 Hz / 45-65 Hz / 400 Hz
- Real-time clock
- Universal auxiliary supply
- Dimension UMT 5x0 160 mm (weight) x 75 mm (height) x 125 mm (depth)
- User friendly and powerful settings software MiGen

Standard EN	Description
61010-1: 2001	Safety requirements for electrical equipment for measurement, control and laboratory use
60688:1995 / A2: 2001	Electrical measuring transducers for converting AC electrical variables into analogue and digital signals
50160:2010	Voltage characteristics of electricity supplied by public distribution networks
61326-1:2006	EMC requirements for electrical equipment for measurement, control and laboratory use - Part 1: General requirements
60529:1997/ A1:2000	Degrees of protection provided by enclosures (IP code)
60 068-2-1/ -2/ -6/ -27/-30	Environmental testing (-1 Cold, -2 Dry heat, -30 Damp heat, -6 Vibration, -27 Shock)
UL 94	Tests for flammability of plastic materials for parts in devices and appliances

Table 1: Compliance with standards

#### Tariff inputs:

- Nominal voltage - Un: 230 V
- Voltage supply: 0.8..1, 15 Un
- Current at nominal voltage < 0.5 mA
- Tariff inputs are electrically isolated from other circuits.



MiGen

# Measuring Transducers

## MT 5x0/UMT 5x0

### - Comparison and common characteristics

Instrument Description	Multifunction Transducer	Network Recorder	Network Analyzer
ANSI type	UMT 540	UMT 550	UMT 560
DIN type	MT 540	MT 550	MT 560
<b>Hardware Configuration</b>			
Accuracy class (typical, of reading) %	0.2	0.2	0.2
Power supply	Uni-LO / Uni-HI*	Uni-LO / Uni-HI*	Uni-LO / Uni-HI*
Energy counters	4	4	4
Real time clock	•	•	•
Remote display connection***	•	•	•
FLASH Memory size	-	8 Mb	8 Mb
Autorange Current	•	•	•
Autorange Voltage	•	•	•
<b>Input Range</b>			
Current - In=5 A, max.12 A	•	•	•
Voltage - Un=500 V L-N, max. 750 V L-N sin	•	•	•
Frequency - 16 2/3 Hz or 45 to 65 Hz or 300 Hz or 400 Hz	•	•	•
<b>Communication</b>			
Communication ports	1 Standard + 1 Optional ***	1 Standard + 1 Optional ***	1 Standard + 1 Optional ***
Comm. type: Serial (RS485 + RS232)/Ethernet/USB/Ethernet & USB**	• / • / - / •	• / • / - / •	• / • / - / •
Comm. protocol: Modbus (RTU, TCP) and DNP3	•	•	•
<b>Inputs/Outputs</b>			
I/O 1: AN / DI / DO / PO / TI / AL	○ / ○ / ○ / ○ / ○ / ○	○ / ○ / ○ / ○ / ○ / ○	○ / ○ / ○ / ○ / ○ / ○
I/O 2: AN / DI / DO / PO / TI / AL	○ / ○ / ○ / ○ / ○ / ○	○ / ○ / ○ / ○ / ○ / ○	○ / ○ / ○ / ○ / ○ / ○
I/O 3: AN / DI / DO / PO / TI / AL	○ / ○ / ○ / ○ / ○ / ○	○ / ○ / ○ / ○ / ○ / ○	○ / ○ / ○ / ○ / ○ / ○
I/O 4: AN / DI / DO / PO / TI / AL / COM2*	○ / ○ / ○ / ○ / ○ / ○ / ○	○ / ○ / ○ / ○ / ○ / ○ / ○	○ / ○ / ○ / ○ / ○ / ○ / ○
<b>Available Functions</b>			
Programmable refresh time (Communication)	•	•	•
MD calculation (TF, FW, SW)	•	•	•
Tariff clock	•	•	•
Cost management	•	•	•
Programmable alarms	32	32	32
Alarms recording	-	•	•
Measurements recording	-	•	•
Power supply quality EN50160	-	-	•
PC Software	MiGen	MiGen	MiGen
<b>Available Measurements</b>			
Actual values: U, I, P, Q, S, PF, PA, f, φ	•	•	•
Energy	•	•	•
Maximum demands	•	•	•
Minimum values: U, I, P, Q, S, PF, PA, f, φ	•	•	•
Maximum values: U, I, P, Q, S, PF, PA, f, φ	•	•	•
THD	•	•	•
Harmonics	up to 31 <sup>st</sup>	up to 31 <sup>st</sup>	up to 63 <sup>rd</sup>

\* Uni-LO: low voltage (45...70 V AC, 19...70 V DC); Uni-HI: high voltage (70...276 V AC, 70...300 V DC)

\*\* With some limits (see User's Manual MT/UMT 5x0)

\*\*\* The optional communication port (COM2) excludes the remote LED display connection and supports only RS485 serial communication type through the 4th I/O connector slot

#### Legend:

- - feature not supported  
 • - standard feature  
 ○ - optional feature  
 PO - pulse output  
 TI - tariff input  
 AL - alarm output

AN - analogue output  
 DI - digital input  
 DO - digital output  
 TF - thermal function  
 FW - fixed window  
 SW - sliding window  
 / - or

# Measuring Transducers

## MT 560/UMT 560 - TRANSDUCER & ANALYZER

### USE

The MT 560/UMT 560 multi transducer and analyzer is used for a permanent analysis of electricity supply quality in compliance with the EN 50160 standard. Records are stored in the internal memory for the period of the last three years. Moreover, more than 100,000 deviations of the measurands from the standard values are stored, which enables finding eventual reasons for the problems in network.

Input ranges width enables measurement of all basic AC voltages and currents. The transducer generates and accepts different I/O signals. An analogue output signal is proportional to measurand and is intended for the control of analogue and digital devices. A pulse output is intended for sending data to devices for checking and supervising consumed energy.



### The transducer measures and records the following characteristics:

- Frequency deviations
- Voltage deviations
- Voltage clips
- Voltage interruptions
- Voltage unbalances
- Over-voltages
- Fast voltage changes
- Flicker intensity
- THD
- Harmonics

Besides the features listed in the chapter “Family of Measuring Transducers MT 5x0/UMT 5x0 - comparison and common characteristics”, the transducer also has other features:

- Harmonic analysis of phase, phase-to-phase voltages and currents up to the 63rd harmonic (only MT/UMT 560)
- 32 adjustable alarms
- Recording up to 32 measurands and 32 alarms in the internal memory (8 MB flash)

Dimensional drawings on page 81.  
Connection diagrams on pages 94-97.  
Software on pages 32-35.

# Measuring Transducers

MT 550/UMT 550 - TRANSDUCER & RECORDER,

MT 540/UMT 540 - MULTIFUNCTION TRANSDUCER



## USE

The MT 550/UMT 550 transducer and analyzer is used for monitoring, measuring and recording measurements of electric quantities in electrical power distribution system. Measurements are stored in internal flash memory (8 MB). Both measuring transducers (U)MT 550 and (U)MT 540 measure basic parameters (U, I, P) very precisely with accuracy class 0.2 according to the IEC EN 60688 standard.

Input range width enables measurement of all basic AC voltage or current. The transducer generates and accepts different I/O signals. An analogue output signal is proportional to measurand and is intended for the control of analogue and digital devices. A pulse output is intended for sending data to devices for checking and supervising consumed energy.

Besides the features listed in the chapter “Family of Measuring Transducers MT 5x0/UMT 5x0 - comparison and common characteristics”, the transducer also has other features:

- Harmonic analysis of phase, phase-to-phase voltages and currents up to the 31rd harmonic
- 32 adjustable alarms
- Recording up to 32 measurands and 32 alarms in the internal memory (8 MB flash, only MT/UMT 550).

Dimensional drawings on page 81.  
Connection diagrams on pages 94-97.  
Software on pages 32-35.

# Measuring Transducers

## RD 500 - REMOTE DISPLAY FOR MEASURING TRANSducers MT 5x0/UMT 5x0



### Features:

- Remote application for measuring transducers (U)MT560, (U)MT550, (U)MT540
- Network connection for up to 32 transducers
- RS485 communication
- Universal power supply 48-276 V AC, 20-300 V DC
- Graphical LCD 128 x 64 dots
- Multilingual support

Remote display is very useful for a quick survey of all measured parameters or for setting up the (U)MT5xx measuring transducers without the PC. Navigation keys and graphical LCD display enable remote application and remote display settings. By choosing different RD 500 target communication addresses it is possible to track measurements and change settings for up to 32 (U)MT 5x0 measuring transducers.

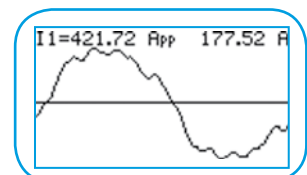
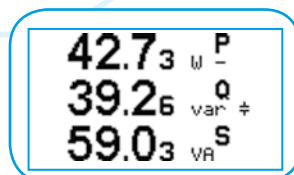
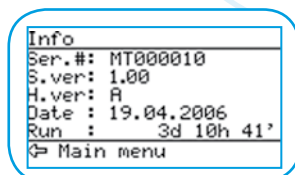
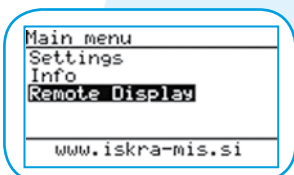
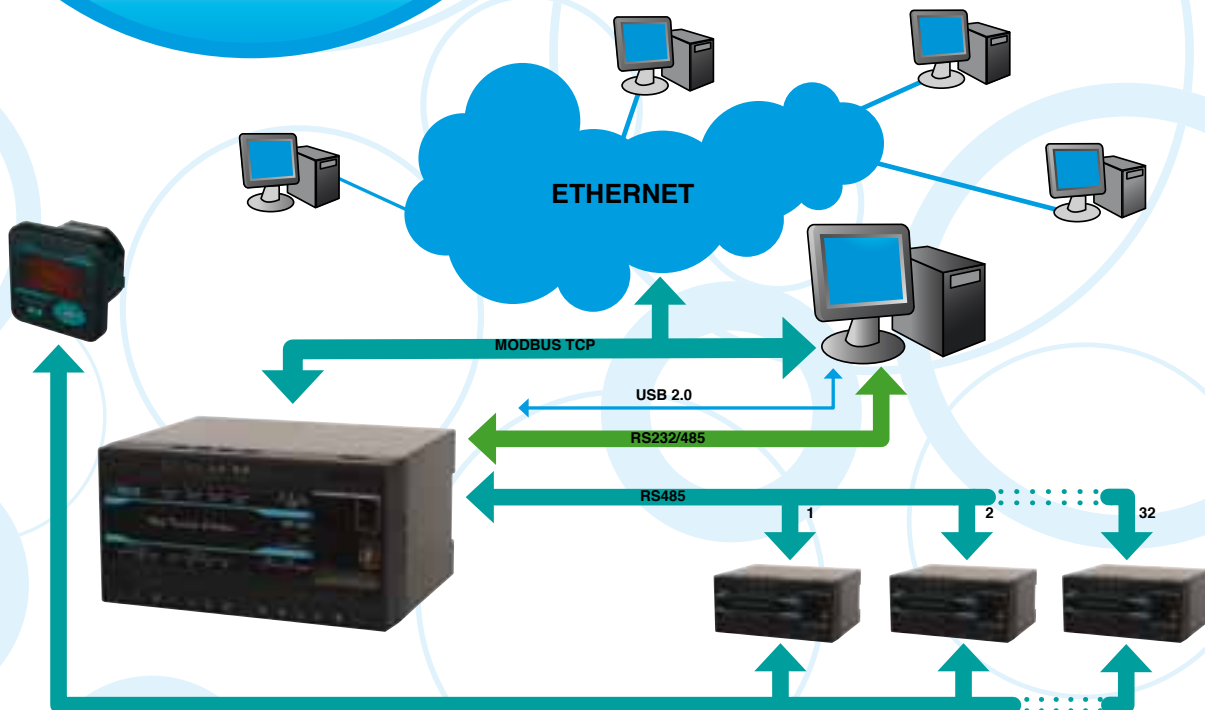

Dimensional drawings on page 81.

# Measuring Transducers

## MT 510/UMT 510 - POWER TRANSDUCER



(U)MT 510 is intended for measuring and monitoring single-phase electrical power network. Voltage and current inputs are electrically isolated from the system by means of highly resistive input chain and current transformer respectively. It measures true RMS values by means of fast sampling of voltage and current signals, which makes instruments suitable for acquisition of transient events. A built-in microcontroller calculates measurands (voltage, current, frequency, energy, power, power factor, power angles, THD U, THD I, MD) from the measured signals.

### Features

- Measurements of instantaneous values of all single phase values; U, I, P, Q, S, f,  $\varphi$ , energy, THD U, THD I, MD
- Power accuracy class 0.2
- 16 adjustable alarms
- Wide frequency range from 16 Hz to 400 Hz
- RS 232/RS 485 communication up to 115,200 bit/s or USB communication or Ethernet and USB communication simultaneously
- MODBUS communication protocol
- Up to 2 inputs or outputs (analogue outputs, digital inputs, alarm (digital) outputs, pulse outputs)
- Universal power supply (two voltage ranges)
- Automatic range of nominal current and voltage (max. 12.5 A and 600 V<sub>L-N</sub>)
- Housing for a DIN rail mounting
- User-friendly PC MiQen software

Dimensional drawings on page 81.  
Connection diagrams on pages 98.  
Software on pages 32-35.

# Measuring Transducers

## MT 511/UMT 511 - POWER TRANSDUCER & RECORDER



(U)MT 511 is intended for measuring and monitoring single-phase electrical power network. Voltage and current inputs are electrically isolated from the system by means of highly resistive input chain and current transformer, respectively. It measures true RMS values by means of fast sampling of voltage and current signals, which makes instruments suitable for acquisition of transient events. A built-in microcontroller calculates measurands (voltage, current, frequency, energy, power, power factor, power angles, THD U, THD I, MD) from the measured signals.

### Features

- Measurements of instantaneous values of all single phase values; U, I, P, Q, S, f,  $\varphi$ , energy, THD U, THD I, MD
- Power accuracy class 0.2
- Recording of up to 8 measurands and 16 alarms in the internal memory (8 MB flash)
- 16 adjustable alarms
- Wide frequency range from 16 Hz to 400 Hz
- RS 232/RS 485 communication up to 115,200 bit/s or USB communication or Ethernet and USB communication simultaneously
- MODBUS communication protocol
- Up to 2 inputs or outputs (analogue outputs, digital inputs, alarm (digital) outputs, pulse outputs)
- Universal power supply (two voltage ranges)
- Automatic range of nominal current and voltage (max. 12.5 A and 600 V<sub>L-N</sub>)
- Housing for a DIN rail mounting
- User-friendly PC MiQen software

Dimensional drawings on page 81.  
Connection diagrams on pages 98.  
Software on pages 32-35.

# Measuring Transducers

## MT 516/UMT 516 - VOLTAGE TRANSDUCER



(U)MT 516 is intended for measuring and monitoring single-phase electrical power network. Voltage input is electrically isolated from the system by means of highly resistive input chain. It measures true RMS voltage value by means of fast sampling of voltage signals, which makes instruments suitable for acquisition of transient events. A built-in micro-controller calculates measurands (voltage, frequency, THD U) from the measured signals. Measurands can then be converted into load independent DC current or voltage which is proportional to the true RMS measured value for the purpose of regulating analogue and/or digital devices.

### Features

- Measurements of true RMS voltage, frequency THD U
- High accuracy class 0.2 (IEC-688)
- Wide frequency range from 16 Hz to 400 Hz
- 16 adjustable alarms
- RS 232/RS 485 communication up to 115,200 bit/s or USB communication or Ethernet and USB communication simultaneously
- MODBUS communication protocol
- Up to 2 inputs or outputs (analogue outputs, digital inputs, alarm outputs, digital outputs)
- Universal power supply (two voltage ranges)
- Automatic range of nominal voltage (max. 600 V<sub>L-N</sub>)
- Housing for a DIN rail mounting
- User-friendly PC MiQen software

Dimensional drawings on page 81.  
Connection diagrams on pages 98.  
Software on pages 32-35.

# Measuring Transducers

## MT 518/UMT 518 - CURRENT TRANSDUCER



(U)MT 518 is intended for measuring and monitoring single-phase electrical power network. Input current is electrically isolated from the system by means of current transformer. (U)MT518 measures true RMS current value by means of fast sampling of current signals, which makes instruments suitable for acquisition of transient events. A built-in micro-controller calculates measurands (current, frequency, THD I) from the measured signals. Measurands can then be converted into load independent DC current or voltage which is proportional to the true RMS measured value for the purpose of regulating analogue and/or digital devices.

### Features

- Measurements of true RMS current, frequency, THD I
- High accuracy class 0.2 (IEC-688)
- Wide frequency range from 16 Hz to 400 Hz
- 16 adjustable alarms
- RS 232/RS 485 communication up to 115,200 bit/s or USB communication or Ethernet and USB communication simultaneously
- MODBUS communication protocol
- Up to 2 inputs or outputs (analogue outputs, digital inputs, alarm outputs, digital outputs)
- Universal power supply (two voltage ranges)
- Automatic range of nominal current (max. 12.5 A)
- Housing for a DIN rail mounting
- User-friendly PC MiQen software

Dimensional drawings on page 81.  
Connection diagrams on pages 98.  
Software on pages 32-35.

# Measuring Transducers

## MT 406 - AC VOLTAGE SELF POWERED TRANSDUCER



MT406 is intended for measuring and monitoring voltage in electrical power network. Voltage input is electrically insulated from the system by means of voltage transformer. The signal is rectified, smoothed and amplified into an independent DC current output.

### APPLICATION

The MT406 voltage transducer is used for a permanent monitoring of a single-phase voltage value. PLCs, PCs, micro-processor control, indicators, alarms units etc. can be operated by the output signal. Voltage input can be connected either directly to low-voltage network or shall be connected to network via a corresponding voltage transformer (with standard 100V output).

### Features:

- Sinusoidal AC voltage measurements
- Voltage range measurements up to 500 VL-N
- Galvanic insulation between input and output
- Accuracy class 0.5
- Self powered
- Housing for DIN rail mounting

Dimensional drawings on page 81.  
Connection diagrams on pages 99.

# Measuring Transducers

## MT 408 - AC CURRENT SELF POWERED TRANSDUCER



MT408 is intended for measuring and monitoring single-phase electrical power network. Current input is electrically insulated from the system by means of current transformer. The signal is rectified, smoothed and amplified into an independent DC current output.

### APPLICATION

The MT408 current transducer is used for a permanent monitoring of a single-phase current value. PLCs, PCs, micro-processor control, indicators, alarms units etc. can be operated by the output signal. Current input can be connected either directly to low-voltage network or shall be connected to network via a corresponding current transformer (with standard 1 A or 5 A output).

### Features:

- Sinusoidal AC current measurements
- Current range measurements up to 6 A
- Galvanic insulation between input and output
- Accuracy class 0.5
- Self powered
- Housing for DIN rail mounting

Dimensional drawings on page 81.  
Connection diagrams on pages 99.

# Measuring Transducers

## MT 416 - PROGRAMMABLE AC VOLTAGE TRANSDUCER



MT416 is intended for measuring and monitoring single-phase electrical power network. Voltage input is electrically isolated from the system by means of voltage transformer. It measures true RMS voltage value by means of fast sampling of voltage signals, which makes instruments suitable for acquisition of transient events. A built-in microcontroller calculates measurands (voltage, frequency, THD U, MD) from the measured signals. Measurands (U, f) can be then converted into load independent DC current or voltage which is proportional to the true RMS measured value for the purpose of regulation of analogue and/or digital devices.

### APPLICATION

The MT416 voltage transducer is used for a permanent monitoring of a single-phase voltage and frequency values. MT416 is delivered configured to default values. Subsequent customer configuration is possible with user friendly setting software MiQen. MT416 supports standard serial RS232/485 with speed up to 115200 bps. USB 2.0 can be used for a fast set-up or memory acquisition (after installation USB connection is not possible any more). Additional USB 2.0 interface can only be used for a fast set-up without need for auxiliary power supply. This interface is NOT galvanically isolated from analogue output and can be used ONLY unconnected to aux. supply and measuring inputs.

### Features:

- True RMS AC voltage measurements
- Voltage auto range measurements up to 600 VL-N
- Frequency measurement range 16 - 400 Hz
- AC or universal wide auxiliary power supply range 24 - 300 Vdc, 40 - 276 Vac
- Accuracy class 0.5 (EN 60688)
- Serial (RS232 or RS485) communication
- Sophisticated analogue output; 2 voltage and 4 current ranges, non-linear characteristics ...
- Simple USB setting without auxiliary power supply

### PROPERTIES

- Measurements of true RMS voltage, frequency THD U and MD
- Accuracy class 0.5 (EN 60688)
- Input frequency range: 50/60 Hz, 400 Hz
- RS 232/RS 485 communication up to 115, 200 bit/s and USB 2.0 communication
- MODBUS communication protocol
- Universal power supply or transformer power supply
- Automatic range (max. 600 VL-N)
- Housing for DIN rail mounting
- User-friendly PC MiQen software

Dimensional drawings on page 81.  
Connection diagrams on pages 99.  
Software on pages 32-35.

# Measuring Transducers

## MT 418 - PROGRAMMABLE AC CURRENT TRANSDUCER



MT418 is intended for measuring and monitoring single-phase electrical power network. Current input is electrically isolated from the system by means of current transformer. It measures true RMS current value by means of fast sampling of current signals, which makes instruments suitable for acquisition of transient events. A built-in microcontroller calculates measurands (current, frequency, THD U, MD) from the measured signals. Measurands (I, f) can be then converted into load independent DC current or voltage which is proportional to the true RMS measured value for the purpose of regulation of analogue and/or digital devices.

### APPLICATION

The MT418 current transducer is used for a permanent monitoring of a single-phase current and frequency values. MT418 is delivered configured to default values. Subsequent customer configuration is possible with user friendly setting software MiQen. MT418 supports standard serial RS232/485 with speed up to 115200 bps. USB 2.0 can be used for a fast set-up or memory acquisition (after installation USB connection is not possible any more). Additional USB 2.0 interface can only be used for a fast set-up without need for auxiliary power supply. This interface is NOT galvanically isolated from analogue output and can be used ONLY unconnected to aux. supply and measuring inputs.

### Features:

- True RMS AC current measurements
- Current auto range measurements up to 12 A
- Frequency measurement range 16 - 400 Hz
- AC or universal wide auxiliary power supply range 24 - 300 Vdc, 40 - 276 Vac
- Accuracy class 0.5 (EN 60688)
- Serial (RS232 or RS485) communication
- Sophisticated analogue output; 2 voltage and 4 current ranges, non-linear characteristics ...
- Simple USB setting without auxiliary power supply

### PROPERTIES

- Measurements of true RMS current, frequency, THD I and MD
- Accuracy class 0.5 (EN 60688)
- Input frequency range: 50/60 Hz, 400 Hz
- RS 232/RS 485 communication up to 115,200 bit/s and USB 2.0 communication
- MODBUS communication protocol
- Universal power supply or transformer power supply
- Automatic range (max. 12 A)
- Housing for DIN rail mounting
- User-friendly PC MiQen software

Dimensional drawings on page 81.  
Connection diagrams on pages 99.  
Software on pages 32-35.

# Measuring Transducers

## MT 440 - MULTIFUNCTIONAL TRANSDUCER



MT440 are intended for measuring and monitoring single-phase or three-phase electrical power network. They measure RMS value by means of fast sampling of voltage and current signals, which makes instruments suitable for acquisition of transient events. A built-in microcontroller calculates measurands (voltage, current, frequency, energy, power, power factor, THD phase angles, etc.) from the measured signals.

### APPLICATION

The MT440 multifunction transducer is used for measuring and monitoring of all single-phase or three-phase values. Wide range of various I/O modules makes MT440 a perfect choice for numerous applications. MT440 is delivered un-configured for customer configuration with user friendly setting software MiQen. MT440 supports standard serial communication RS232 or RS485 with speed up to 115200 baud, which is perfect for simple applications and serial bus interfacing. Additional USB 2.0 interface can only be used for a fast set-up without need for auxiliary power supply. This interface is NOT galvanically isolated from power inputs (aux. supply and measurement inputs) and can be used ONLY unconnected to power inputs.

### Features:

- Voltage and current auto range measurements up to 600V, 12.5A
- Universal wide auxiliary power supply range 24 - 300 Vdc, 40 - 276 Vac
- Power accuracy class 0.5 (EN 60 688)
- Up to four I/O modules (analogue out, pulse out, alarm out, general purpose digital out)
- Sophisticated analogue out; 2 voltage and 4 current ranges, non-linear characteristics ...
- Simple USB setting without auxiliary power supply

### PROPERTIES

- Measurements of instantaneous values of more than 50 quantities (V, A, kW, kVA, kvar, kWh, kvarh, PF, Hz, MD thermal, THD, etc)
- Power accuracy class 0.5
- 16 adjustable alarms
- Input frequency: 50/60 Hz, 400 Hz
- Serial communication (RS232 or RS485 up to 115,200 bit/s) and USB 2.0
- MODBUS communication protocol
- Up to 4 I/O (analogue outputs, alarm outputs, pulse outputs, general purpose relay output, general purpose solid-state output)
- Single wide auxiliary power supply range 24 - 300 Vdc, 40 - 276 Vac
- Automatic range of current and voltage (max. 12.5 A and 600 VL-N)
- Housing for DIN rail mounting
- User-friendly setting software, MiQen

# Measuring Transducers

## MI 4xx - MEASURING TRANSDUCER

- Resistance MI 452
- DC voltage MI 456
- DC current MI 458
- Temperature with Pt 100 MI 450
- TAP position MI 454



Type / Description	Accuracy class	Inputs	Housing width (a)
MI 452 Temperature with Pt 100, Pt 1000, Ni 100	0.5	2-wire, 3-wire, 4-wire	45 mm
MI 452 Resistance	0.5	R = 0 ... 10 Ω ... 50 kΩ R = 0 ... 100 Ω ... 500 kΩ	45 mm
MI 454 TAP position	0.5	100 Ω ... 50 kΩ 1000 Ω ... 500 kΩ	45 mm
MI 456 DC voltage	0.5	U = 50 mV ... 1 V DC U = 1 V ... 50 V DC U = 50 V ... 400 V DC	45 mm
MI 458 DC current	0.5	I = 1 ... 10 mA DC I = 10 ... 100 mA DC	45 mm

AC auxiliary power supply: 57, 63.5, 100, 110, 230, 400, 500 V

**Options:**  
 RS 232 or RS 485 serial communication port  
 Universal aux. power supply for DC & AC 24 ... 300 V DC / 40 ... 276 V AC

\* Power supply from a measuring circuit only. Communication port and aux. power supply are not available. Output 0.5 mA, 10 mA, 20 mA.

Dimensional drawings on page 81.  
 Connection diagrams on pages 101.  
 Software on pages 32-35.

## MiBOX



### PLUG AND PLAY “OUT-OF-THE-BOX” DEVICE FOR MONITORING/RECORDING/CONVERTING/ALERTING DATA

#### USE

- For buildings managers and owners, utility companies, AMR solutions, EM solutions providers.
- PCCI (Point-of-Common-Coupling Interface) for integration of Smart Grids and Distributed Energy Resources. PCCI is used for a simple, standardized connection of micro and small generation of electricity from distributed resources to the distribution network. PCCI functionalities include remote monitoring and control, communication with the control center, power quality monitoring according to EN 50160, possibility of controlling compensation devices, various protection functions (voltage, frequency, island operation, etc.).
- Concentrator/Converter - used as protocol converter between Iskra-MIS products and other devices. IEC61850 module in server configuration already supported, DNP3 slave module in a development stage.
- LiSa - MiBox is a basic module of a LiSa system. LiSa is a system for detection of different errors on middle-voltage overhead transmission lines and transformer stations.

#### FEATURES:

- Embedded platform with middle range requirements
- Preinstalled MiSmart application
- The unit is independent from external resources with all the system's components already included (measuring system, database, set-up application and monitoring application)
- For monitoring/collecting data from measuring devices, alert handling, controlling and data management
- administration of the MiBox and data analysis/management is supported also over a web interface
- IP-based network (Ethernet, GPRS/UMTS, optionally WiFi) for primary use and with local communication (USB, serial) for secondary use
- Function of protocol conversion
- Industrial temperature range from -25°C to +50°C

#### BENEFITS:

- Extensions of the existing systems and applications possible
- Upgrade possibilities (local and remote)
- Cost benefits due to the partial upgrades
- Open platform with customer add-on extensions
- Support for standard communication protocols (IEC61850, OPC, ...)

Dimensional drawings on page 81.  
Connection diagrams on pages 90, 91.  
Software on pages 31-34.

# Measuring Centres

MiBOX

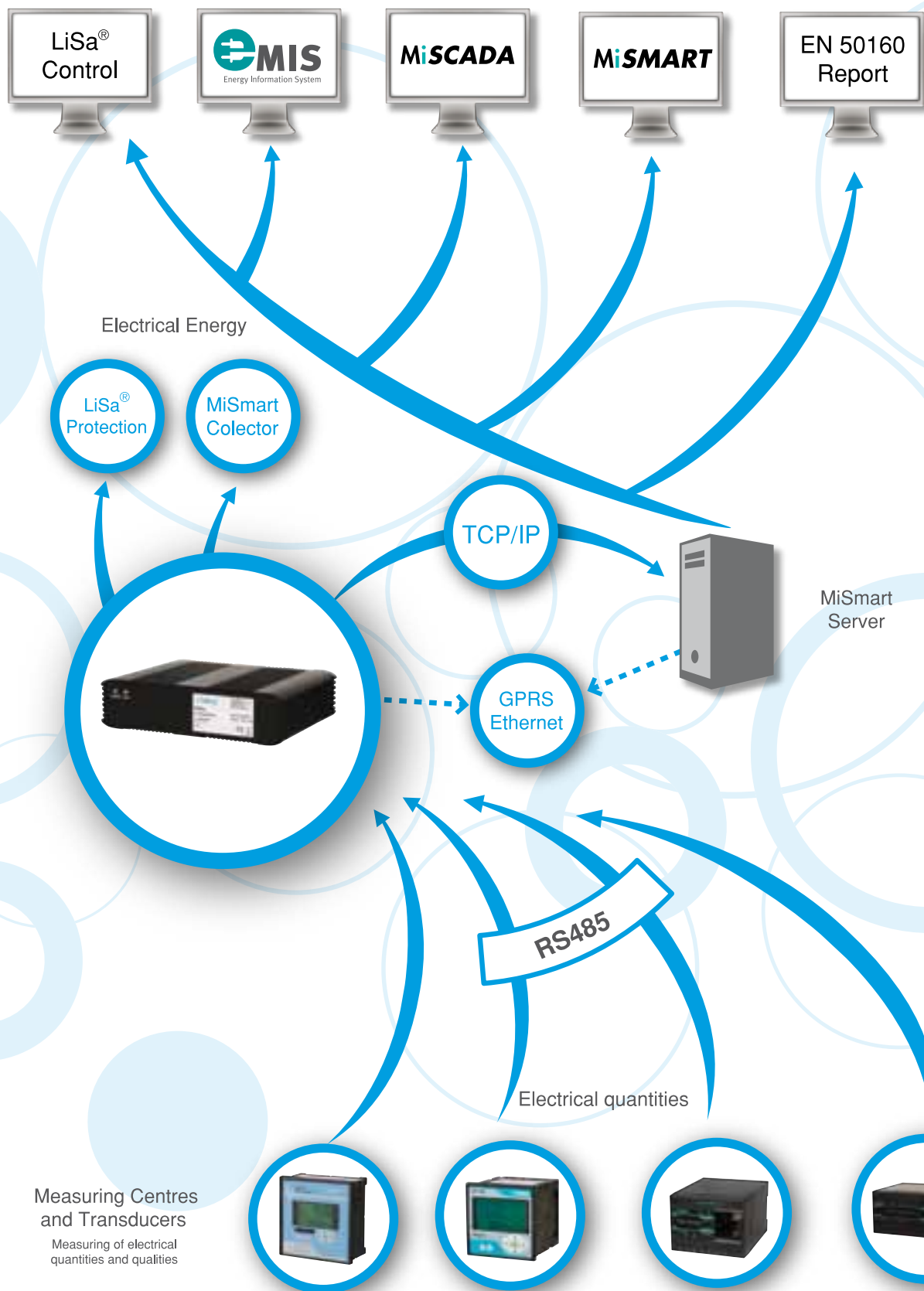

# Software

## MIQEN

MiQen software is a tool for complete monitoring of the measuring instruments. RS485/RS232 or TCP/IP communication is used for connection with a PC. A user-friendly interface consists of five segments: device management, counter settings, real-time measurements, data analyses and programs updating.

### Device management

As easy as possible.

Just select the device in a favourites line.

Use the network explorer to set and explore the devices network. Communication parameters of all devices and their addresses in network can be easily set.

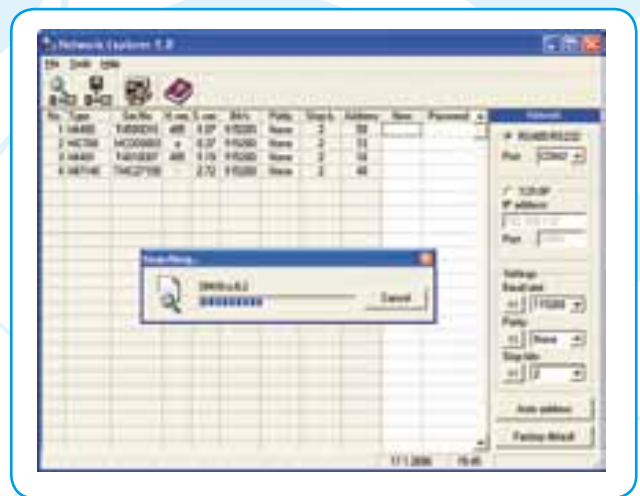

### Instrument setting

Multi Register Edit technology assures a simple modification of settings that are organised in tree structures. Besides settings transfer into the instrument, storing and reading from the setting files and MMCs are also available.

### Real-time measurement

All supported measurements can be seen in real time in a table form, while harmonics and their time-reconstructed signals are also displayed graphically. For further processing of the results of measurements, copying via a clipboard into standard Windows formats is supported.

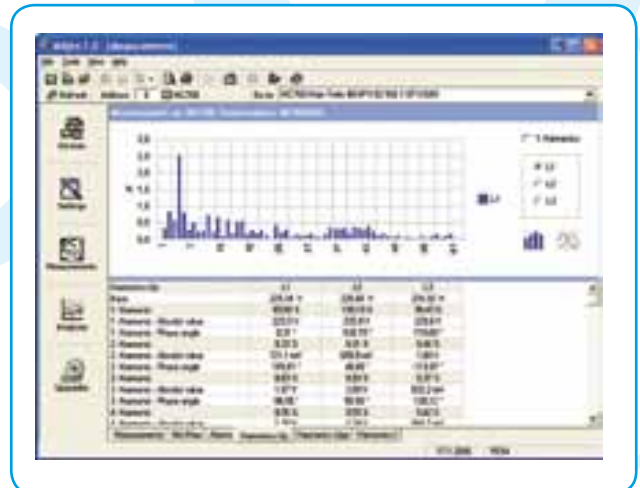
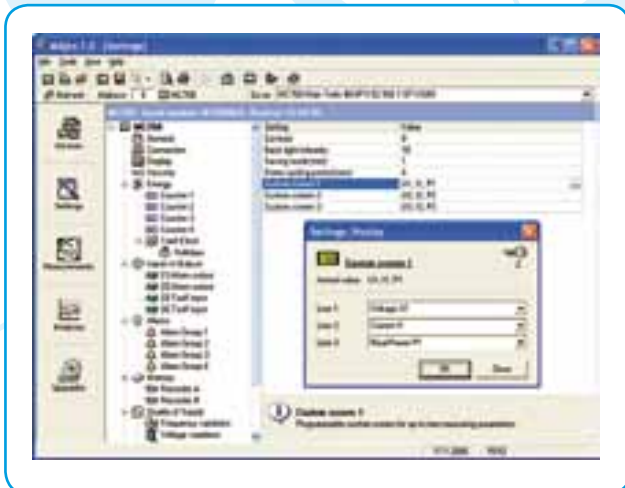

### Data analysis

Analysis can be performed for the instruments with a built-in memory. Recorded quantities can be monitored in a tabular or graphical form, events that triggered alarms can be analysed or a report on quality of supply voltage can be made. All data can be exported to the Access data base, Excel worksheets or text files.



### Programs updating

Always use the latest version of software, both MiQen and software in the instrument. The program automatically informs you on available upgrades that can be transferred from the web site and used for upgrading.



### System requirements:

Windows 98, 2000, Millennium, XP, NT4.0, 100 MB capacity on a hard disc, VGA Screen, 64 MB RAM, CD drive, RS232 communication port

### There are two versions of MIQEN software:

- **standard edition** - all functions available except for data analysis, free of charge
- **professional edition** - all functions available for installation, you have to buy a CD key

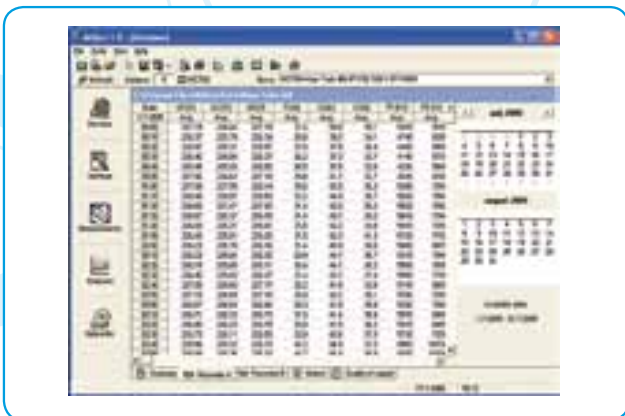

## MiSMART

**MiSMART** is an integrated software platform for centralized acquisition, storage and representation of data captured by distributed measurement devices. It enables monitoring of a large number of metering points. All captured data can be remotely accessed by a simple web browser. Easy integration of third party tools and data analysis software make it highly adaptable to any range of customized user applications. The most common fields of implementation are energy management, monitoring of energy production, transformer station monitoring, automated meter reading etc.

### CUSTOMER BENEFITS

- complete turn-key solution for remote data acquisition and management
- integrated tools for data management
- highly customized for Iskra MIS measurement devices for efficient system operation
- utilization of wide range of communication technologies for best network configuration (serial, ethernet, GPRS, SMS, low power radio etc.)
- immediate alarming and notification
- reliable off-load data collection, based on data redundancy
- easy integration of third party tools and software

### MiSMART PLATFORM:

- **MiSMART** data collector
- **MiSMART** database
- **MiSMART** web server

Windows based platform with three-tier architecture for efficient platform management.

It utilizes innovative push data collection mechanism combined with advanced instruments with built in memory for data redundancy resulting in high data collection reliability.

### MiSMART DATA COLLECTOR:

- captures measurements, alarms, settings and power quality reports
- real time alarm management
- automatic time synchronization of devices
- possible compressed binary data transfer to minimize network load
- configurable data resolution

### MiSMART DATABASE:

- stores measurements, alarms, settings and power quality reports
- implemented on MSSQL database
- centralized or distributed data storage
- standard database interfaces enable easy access to external third party applications

### MiSMART WEB SERVER:

- multi client connections
- multi user management
- graphical and numerical data representation
- web configuration and activity monitor
- monitoring of measurements, alarms and power quality reports

A user client can connect to the MiSMART Web Server with a standard internet browser.

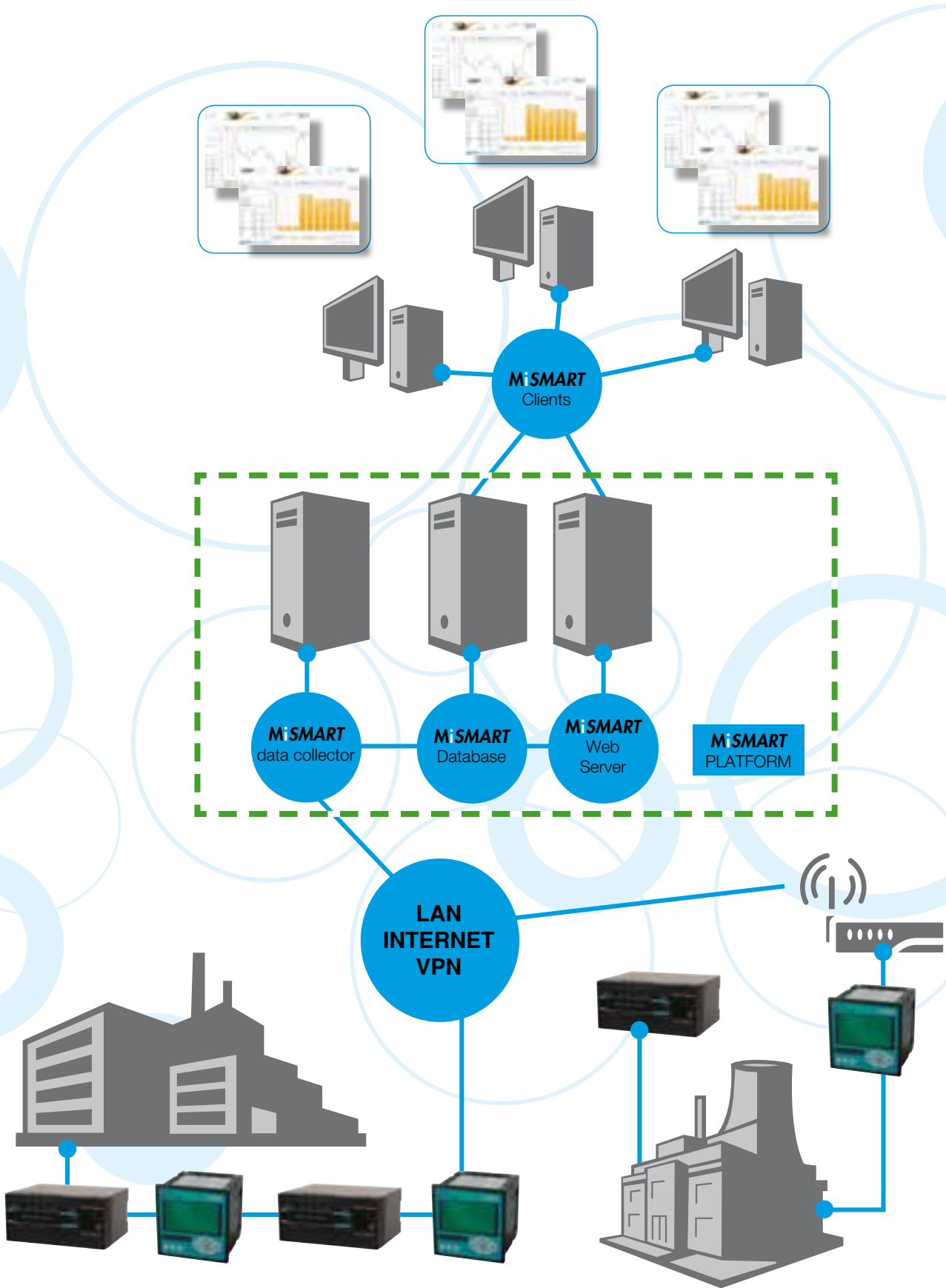

# Communication Adapters

## MI 480 - GSM DEVICE FOR REMOTE CONTROL

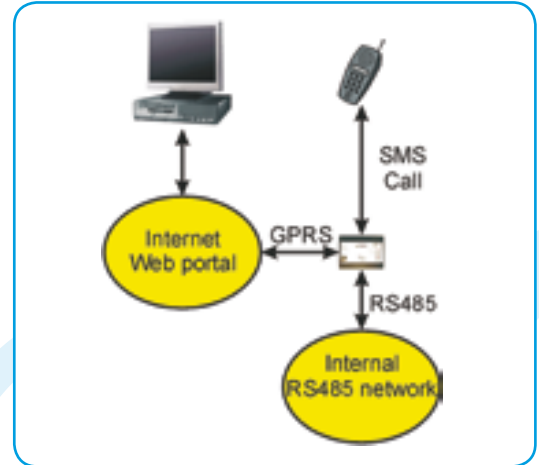

MI 480 is a device with a built-in GPRS modem interface for collecting and sending measurements from the connected instruments to the web portal. It is ideal for controlling distant objects, such as power plants, pumps, transformer stations, measuring stations, temperature monitoring...).

Data are collected in the MI 480 internal memory and sent in packets via the GPRS communication to the web portal. Alarms can be immediately forwarded to various mobile phone numbers.

### Main features are:

- Alarms via an SMS message to a mobile phone
- Trend alarms via an SMS message to a mobile phone
- Data on instantaneous measurements via SMS
- Sending measurement packages to the server for further processing
- Survey of all measurements via a web portal
- All settings are accessible via a web portal

Due to its characteristics, MI 480 is an ideal instrument to be used in systems where permanent or periodical monitoring, storing the measurements for momentary and later analysis and processing are required. The system can be adapted to the needs and requirements of the individual user or system to which it is built-in.

Dimensional drawings on page 81.  
Connection diagrams on pages 101.

# Communication Adapters

## MI 480 - GSM DEVICE FOR REMOTE CONTROL

### RS485 communication

RS485 communication enables connection of up to 32 instruments with one MI 480 device. It is limited to the maximum connection length of 1000 m. Connection of the RS485 communication is described in tables and figures below.

MI 480	RS485	Measuring centres	Measuring transducers
A (21)	DATA +	A (8)	A (21)
B (23)	DATA -	B (7)	B (23)

### Contacts for RS485 communication

MI 480	MI 485 RS485	MI 485 RS232	Measuring centres	Measuring transducers
A (21)	A (21)	Rx (24)	Rx (3)	Rx (24)
		GND (25)	GND (5)	GND (25)
B (23)	B (23)	Tx (26)	Tx (2)	Tx (26)

### Contacts for connection via MI485 interface

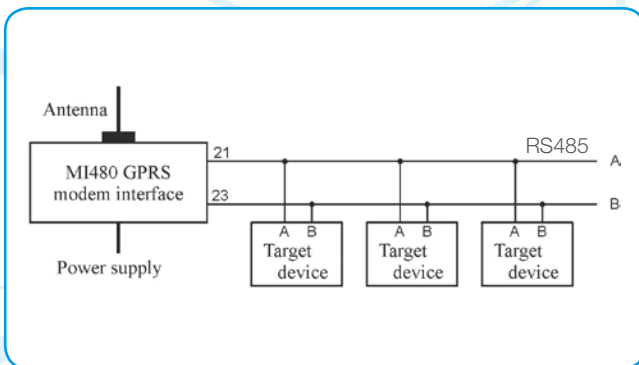

Connection of modem interface

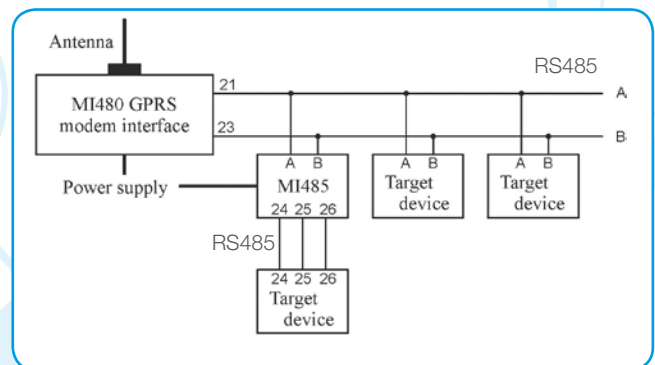

Connection of the instrument via MI 485 interface

### Web portal

The web portal is the user's access point for setting and analysing collected data. It is used in a remote control system for a small power station and a system for detecting cut transmission lines and controlling transformer station defects. For better understanding of information flow see the figure below.

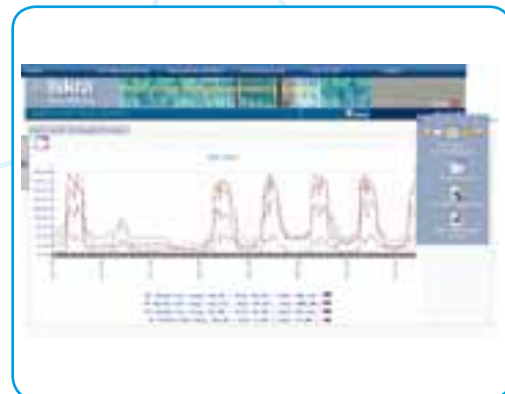
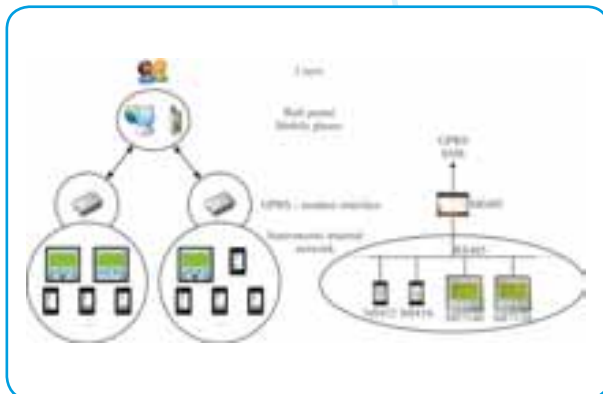

# Communication Adapters

## MI 485 - RS232/RS485 INTERFACE



MI 485 can be used for integrating devices with RS232 communication into RS485 network or as a connection between RS485 network and a control device (PC, PLC, etc.)

The MI 485 communication adapter is used for converting RS485 signal to RS232 signal and vice versa. Signals are electrically isolated. No settings are required and the device is ready for use. Communication speed is up to 115,200 bps.

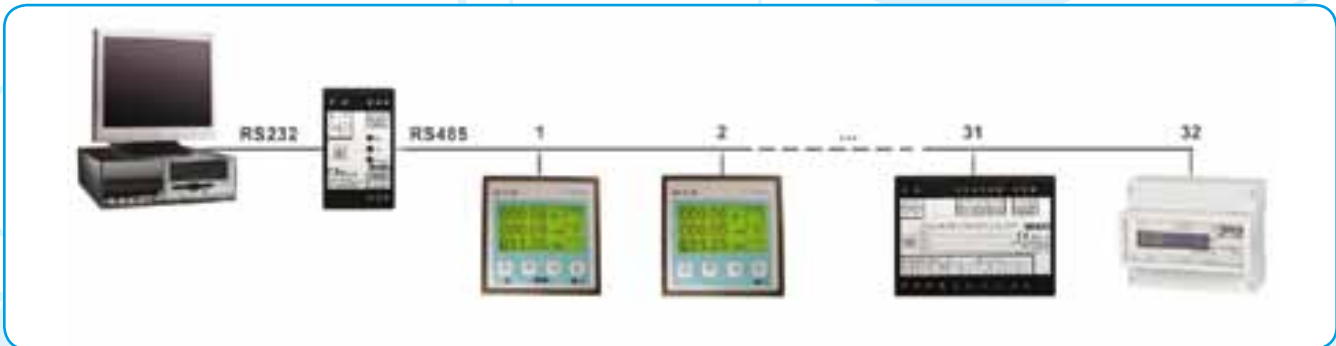

### Connections:

- **Auxiliary supply** - connected with connection terminals 13, 14
- **RS 232 communication**, max. length 3 m

MI 485	Computer - DB9
Tx (26)	Rx (2)
Rx (24)	Tx (3)
GND (25)	GND (5)

- **RS 485 communication**, up to 32 devices, a line should be terminated with a 120  $\Omega$  resistor.

MI 485	RS 485-instruments
A (21)	DATA +
B (23)	DATA -

Dimensional drawings on page 81.  
Connection diagrams on pages 101.

# Communication Adapters

## MI 486 – RS232 INTERFACE - TCP/IP

## MI 488 – RS485 INTERFACE - TCP/IP

The MI 486, MI 488 communication adapters are used for connecting the instruments with RS232 or RS485

communication on the Ethernet network. The instruments are connected to the computer through the Ethernet network. Signals are electrically isolated. Data are read from the instruments through interfaces. Communication speed is up to 115,200 bps.

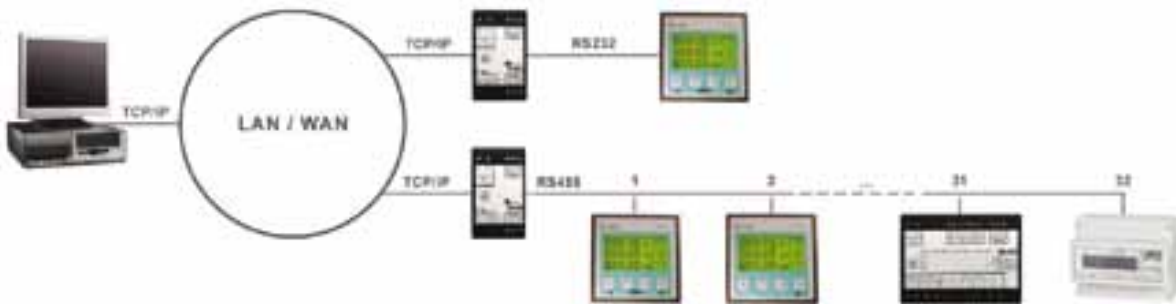

### Connections:

- Auxiliary supply - connected with connection terminals 13, 14
- Ethernet connection - connected with 10/100 RJ45 connection terminal
- RS232 communication (for MI 486), max. length 3 m

MI 486	Computer - DB9
Tx (26)	Tx (2)
Rx (24)	Rx (3)
GND (25)	GND (5)

- RS485 communication (for MI 488), up to 32 devices, a line should be terminated with a 120  $\Omega$  resistor.

MI 488	Instruments with RS485
A (21)	DATA +
B (23)	DATA -

Dimensional drawings on page 81. Connection diagrams on pages 101.

# Digital Meters

## DIGITAL METERS WITH LED DISPLAY

Digital meters with LED display enable fast and accurate survey of electric quantities and are convenient for industrial use as well as for the production and distribution of electric energy. They are panel mounted and enable measurement of TRMS values of electric quantities.



### Features:

- True RMS measurements
- LED Displays with 4 or 3 digits
- Measurement ranges from 0...500 V and 0...9999 A
- CT ratio adjustment for A-meters ... /5 A
- CT ratio from 1 ... 2000
- Measurement range for Frequency meters 20 ... 500 Hz.
- Accuracy  $\pm 1\%$  ( $\pm 0.2\%$  for Frequency meters)
- Power supply 230 V AC  $\pm 20\%$ , 50/60 Hz
- Power consumption  $< 3\text{ VA}$
- Ambient temperature:  $-5\text{ }^{\circ}\text{C}$  ...  $+55\text{ }^{\circ}\text{C}$

# Digital Meters

## DIGITAL METERS WITH LED DISPLAY

Type	DM 206 Voltmeter	DM 208 Ammeter	DM 306 Voltmeter	DM 308 Ammeter	DM 310 Multimeter	DM 202 Frequency meter	DM 302 Frequency meter
Front frame (mm)	72 x 72	72 x 72	96 x 96	96 x 96	96 x 96	72 x 72	96 x 96
Display	3-digit	4-digit	3-digit	4-digit	Ammeter: 3 x 4-digit Voltmeter: 3-digit Frequency meter: 3-digit	3-digit	3-digit
Accuracy	$\pm 1\% + 2d$	$\pm 1\% + 2d$	$\pm 1\% + 2d$	$\pm 1\% + 2d$	Ammeter: $\pm 1\% + 2d$ Voltmeter: $\pm 1\% + 2d$ Frequency meter: $\pm 0,2\% + 2d$	$\pm 0,2\% + 2d$	$\pm 0,2\% + 2d$
Measuring range	0...500 V	0...9999 A	0...500 V	0...9999 A	Ammeter: 0...9999 A Voltmeter L1, L2, L3: 0...500 V Frequency meter: 30...70 Hz	20...500 Hz (30...500 V AC)	20...500 Hz (30...500 V AC)
Power Supply	230 V AC $\pm 20\%$ , 50/60 Hz						
CT ratio*	-	1...2000	-	1...2000	1...2000	-	-
Power consumption	< 3 VA	< 3 VA	< 3 VA	< 3 VA	$\leq 3$ W	$\leq 3$ W	$\leq 3$ W
Ambient temperature	- 5 °C ... + 55 °C						
Weight (kg)	0,23	0,23	0,28	0,28	0,29	0,26	0,30

\*CT ratio: 1, 2, 3, 4, 5, 6, 8, 10, 12, 15, 20, 25, 30, 40, 50, 60, 80, 100, 120, 150, 160, 200, 250, 300, 320, 360, 400, 500, 600, 700, 800, 900, 100, 1200, 1400, 1600, 1800, 2000.

Dimensional drawings on page 83.

# Synchronization Meters

SQ 0104, SQ 0114, SQ 0204, SQ 0214,  
ZQ 1207, FQ 1207, ZQ 1208, FQ 1208



SQ 0214



ZQ 1207  
FQ 1207

If you want to synchronise a generator and a bus bar manually or semi-automatically, SQ 0214 and SQ 0204 are the right instruments for you. Our synchronization meters are very unique products, especially SQ 0214. Synchronization meters are intended for manual or semi-automatic synchronization of two electric-energy distribution systems. SQ 0204, SQ 0214 synchrosopes are the instruments for measuring a phase angle between two electric-energy distribution systems. The SQ 0214 type also measures voltages and frequencies of both systems. On request, both types can be on request provided with a built-in relay output which signals if the conditions for synchronization have been met. ZQ 1207 or ZQ 1208 two-system frequency meter is used for measuring frequencies in two networks. FQ 1207 or FQ 1208 double voltage meter measures voltages in two networks.

TYPE	SQ 0104	SQ 0114	SQ 0204	SQ 0214	ZQ 1207	ZQ 1108	ZQ 1208	FQ 1207	FQ 1108	FQ 1208
Front frame (mm)	144 x 144	144 x 144	96 x 96	96 x 96	96 x 96	144 x 144	96 x 96*	96 x 96	144 x 144	96 x 96*
Cutting for mounting (mm)	138 x 138	138 x 138	92 x 92	92 x 92	92 x 92	138 x 138	92 x 92	92 x 92	138 x 138	92 x 92
Scale length (mm)	360°	360°	360°	360°	92/72	2 x 50	2 x 50	92/72	2 x 50	2 x 50
Accuracy class	+/-1° el.	+/-1° el.	+/-1° el.	+/-1° el.	0.5	0.5	0.5	1.5	1.5	1.5
<b>RATING</b>										
100 V, 230 V	•	•	•	•	•	•	•	•	•	•
400 V	•	•	•	•	•	•	•	•	•	•
500 V	•••	•••	•••	•••		•			•	•
600 V	•••	•••	•••	•••					•	•
Frequency		•		•	•	•	•			

\* ZQ 1208 and FQ 1208 for front frame 144 x 144 mm on request.

\*\* Other ratings on demand

Ship version meters SQ 0204, SQ 0214, ZQ 1207 and FQ 1207 are available on request.

Two voltages ( $U_{gen}$ ,  $U_{bb}$ ) and two frequencies ( $f_{gen}$ ,  $f_{bb}$ ) are displayed on LCD at SQ 0214. When the difference between  $f_{gen}$  and  $f_{bb}$  is smaller than 0.02 Hz,  $U_{BUS}$ ,  $U_{GEN}$ ,  $F_{BUS}$  and  $\Delta\varphi$  are displayed.

Generator voltage  $U_{gen}$  Generator frequency  $f_{gen}$

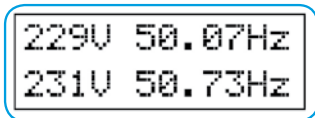

Bus-bar voltage  $U_{bb}$  Bus-bar frequency  $f_{bb}$

Generator voltage  $U_{gen}$  Bus-bar frequency  $f_{bb}$

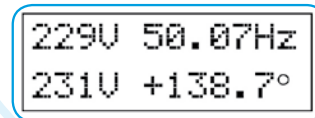

Bus-bar voltage  $U_{bb}$  Phase difference  $\Delta\varphi$

Dimensional drawings on page 73.  
Connection diagrams on pages 103.

# Energy Meters with Power Display

WQ 0217, WQ 1217, WQ 0207, WQ 2207, WQ 1247

Energy meters display instantaneous power in single and three-phase systems with balanced or unbalanced load. Accuracy classes are 1 for energy measurement (EN 61036), 1.5 for power measurement and 2.5 power factor measurement.



WQ 1217



WQ 2207

TYPE	WQ 0217	WQ 1217	WQ 0207	WQ 2207	WQ 1247
Front frame (mm)	96 x 96	96 x 96	96 x 96	96 x 96	96 x 96
Cutting for mounting (mm)	92 x 92	92 x 92	92 x 92	92 x 92	92 x 92
Scale length (mm) / Number of counters	- / 1	- / 2	95 / 1	125 / 1	- / 2 LCD
Voltage input 100 V, 110 V, 230 V, 400 V, 500 V					
Current input 1 A, 5 A					
1b, 1br Single phase system	•	•	•	•	•
3b, 3br Three-phase three-wire balanced load system	•	•	•	•	•
3u, 3ur Three-phase three-wire balanced load system	•	•	•	•	•
4b, 4br Three-phase four-wire balanced load system	•	•	•		
4u, 4ur Three-phase four-wire unbalanced load system	•	•	•	•	•
<b>Option</b>					
One impulse output	•	•	•	•	•
Two impulse outputs	•	•	•	•	•
57 V, 110 V, 230 V, 400 VAC Auxiliary supply	•	•	•	•	•

Dimensional drawings on pages 77-79.  
Connection diagrams on pages 93.

# Hour Meters & Pulse Counters

## HOUR METERS HK 46, HK 47, HK 48, HK 49, HK 30

Hour meters show operation time of machines, equipment and other devices. When you need accurate information for testing, maintenance or warranty purposes, choose from a wide range of HK hour meters produced by Iskra MIS. AC applications: business machines, control panels, compressors, generators, pumps, air conditioning DC applications: garden and farm equipment, Gen-sets, construction equipment.



HK 46



HK 47



HK 48, HK 49



HK 30

		HK 46	HK 47	HK 48, HK 49	HK 30
AC	Voltages	24 V, 48 V, 60 V, 110 V, 120 V, 230 V, 240 V, 400 V (±10%)	24 V, 48 V, 60 V, 110 V, 120 V, 230 V, 240 V, 400 V (±10%)	24 V, 48 V, 60 V, 110 V, 120 V, 230 V, 240 V, 400 V (±10%)	24 V, 48 V, 60 V, 110 V, 120 V, 230 V, 240 V, 400 V (±10%)
	Frequency	50 Hz, 60 Hz	50 Hz, 60 Hz	50 Hz, 60 Hz	50 Hz, 60 Hz
	Counting range	99999.99 h	99999.99 h	99999.99 h	99999.99 h
	Number of digits	5 integers, 2 decimals	5 integers, 2 decimals	5 integers, 2 decimals	5 integers, 2 decimals
	Operating temperature	-25 °C ... +80 °C	-25 °C ... +80 °C	-25 °C ... +80 °C	-25 °C ... +70 °C
DC	Voltages	6-30 V, 10-80 V, 110 V (±10%)	6-30 V, 10-80 V, 110V (±10%)	6-30 V, 10-80 V, 110 V (±10%)	6-12 V, 12-36 V, 36-80 V, 110 V (±10%)
	Counting range	999999.9 h	999999.9 h	999999.9 h	999999.9 h
	Number of digits	6 integers, 1 decimal	6 integers, 1 decimal	6 integers, 1 decimal	6 integers, 1 decimal
	Operating temperature	-20 °C ... +70 °C	-20 °C ... +70 °C	-20 °C ... +70 °C	-10 °C ... +55 °C

		HK 46	HK 47	HK 48, HK 49	HK 30
Protection		IP40, front side	IP65, front side	IP40, front side	IP40, front side
		IP20, terminals	IP00, terminals	IP00, terminals	IP20, terminals
Front dimensions		48 x 48 mm	Ø 58 mm	HK 48 72 x 72 mm - HK 49 96 x 96 mm	36 x 24 mm
Adapter frames		52x52, 55x55, 72x72, Ø 80 mm	Ø 72 mm, Ø 80 mm		48 x 24, 54 x 29, 48 x 48, 55 x 55, Ø 72 x 72 mm 52 mm in Ø 72 mm
Special protection		IP65, front side IP20, terminals	IP67, front side IP00, terminals	IP20, terminals	IP65 front side (transparent housing), IP00 terminals
Approval		UL	UL	UL	CE mark, UL recognized
Connection		plug 6.3 x 0.8 mm with screw plug 6.3 x 0.8 mm screw terminals	plug 6.3 x 0.8 mm with screw plug 6.3 x 0.8 mm	screw terminals	plug 6.3 x 0.8 mm with screw plug 6.3 x 0.8 mm screw terminals for mounting D

		HK 46	HK 47	HK 48, HK 49	HK 30
Mounting	Tip	HK 46 CUTOUT	HK 47 CUTOUT	HK 48, HK 49 CUTOUT	HK 30 CUTOUT
aluminium clamp	A	4 Ø 15 mm	Ø 15 mm		
retainer	G	45 x 45 mm, chamfer edge Ø 45 mm			32 x 32 mm
DIN-rail	D				Ø 50 mm
snap fastener	F				
Antivibration rubber, ø 80 mm	C		Ø 80 mm		
3- screw front mounting ø 72 mm	H	screw terminals	Ø 72 mm		min. Ø 50 mm
				two fixing screws	
					HK48: 68 mm HK49: 92 mm

# Hour Meters & Pulse Counters

## PULSE COUNTERS SI 63, SI 64, SI 65, MC 703 & MC 723



SI 63



MC 703, MC 723



SI 64

Pulse counters are used to keep record of repetitive operations. Typical applications are event counting, quantity counting, coin handling etc.

Type	SI 63	SI 64	SI 65	MC 703, MC 723
	totalizing counters without reset	totalizer with manual reset	mini pulse counter with manual reset	totalizing counters without reset
Supply voltage DC	6 V, 9 V, 12 V, 24 V ( $\pm 10\%$ )	12 V, 24 V ( $\pm 10\%$ )	12 V, 24 V ( $\pm 10\%$ )	3 V, 5 V, 12 V, 24 V ( $\pm 10\%$ )
Supply voltage AC		24/115/230 V ( $\pm 10\%$ )	24/115/230 V ( $\pm 10\%$ )	
Display	6-digit	6-digit	5-digit	6-digit or 7-digit
Counting range	999999	999999	999999	999999 or 9999999
Power consumption	1W	approx. 2 W - V DC approx. 2.9 VA - V AC	approx. 0.5 W - V DC approx. 0.75 VA - V AC 115V AC approx. 1.5 VA - 230 V AC	approx. 300 mW at 3 and 5 V DC approx. 500 mW at 12 and 24 V DC approx. 1.5 V AC 230 V AC
Max counting speed	10 pulses/sec.	25 pulses/sec. - V DC 18 pulses/sec.	10 pulses/sec.	10 pulses/sec.
Protection	IP 20			IP 31 - versions C and D IP 65 - versions A and B
Connection	wire lead 200 mm	silver plated round pins dia 1.5 mm	150 mm flying leads AWG 22	wire lead 140 mm or soldering pins $\phi$ 0.6 mm

### VERSION & MOUNTINGS

Type	Front dimensions	Cutout
SI 63.0 rear screw mounting; aluminium housing	30 x 18.9 mm	30 - 18.9 mm
SI 63.1 snap fastener mounting; transparent plastic housing	33.4 x 27.1 mm	30.5 x 24.5 mm
SI 63.2 2-screw front snap fastener mounting; transparent plastic housing	33.4 x 30 mm	min. 30.5 x 22 mm
SI 64 panel mount with spring clip fastening	53 x 28 mm	50 x 25 mm
SI 65 DIN housing for panel mount with clip	48 x 24 mm	45 x 22 mm
MC 703.xxA front reading, 4 pins on the top, PCB mount	25.2 x 13.5 mm	-
MC 703.xxB top reading, 4 pins on the bottom, PCB mount	25.2 x 31 mm	-
MC 703.xxC front reading, 2 pins behind, rear screw mount	25.2 x 13.8 mm	25.2 x 13.8 mm
MC 703.xxD front reading, wire lead behind, rear screw mount	25.2 x 13.8 mm	25.2 x 13.8 mm
MC 723.xxC front reading, 2 pins behind, snap fastener mount	30 x 20 mm	26.5 x 13.8 mm
MC 723.xxD front reading, wire lead behind, snap fastener mount	30 x 20 mm	26.5 x 13.8 mm

xx: 60 (6-digit) or 70 (7-digit)

# Analogue Meters

## ACTIVE OR REACTIVE POWER METERS



EQ 0207



EQ 2207

Power meters are electronic meters intended for measuring active or reactive power in single phase or three-phase networks, with balanced or unbalanced load. The accuracy class is 1.5.

The scale value depends on primary values of current and voltage. It is defined by the following formulas:

	active power	reactive power
<b>for single phase system</b>	1b $I_{prim} \times U_{prim} \times \cos \varphi$	1br $I_{prim} \times U_{prim} \times \sin \varphi$
<b>for three-phase system</b>	3u $\sqrt{3} I_{prim} \times U^{*prim} \times \cos \varphi$	3ur $\sqrt{3} I_{prim} \times U^{*prim} \times \sin \varphi$
<b>for three-phase system</b>	4u $3 I_{prim} \times U_{prim} \times \cos \varphi$	4ur $3 I_{prim} \times U_{prim} \times \sin \varphi$

\*  $U_{L-L}$  In the equations U means phase voltage at single phase network and three-phase four-wire network 4u as well as line-to-line voltage at three-phase three-wire network 3u. Ratio between the selected final scale value and calculated power should be within the limits from 0.6 to 1.2 at  $\cos \varphi = 1$  or  $\sin \varphi = 1$ .

TYPE	EQ 0307	EQ 0207	EQ 0107	EQ 2307	EQ 2207**	EQ 2107
Front frame (mm)	72 x 72	96 x 96	144 x 144	72 x 72	96 x 96	144 x 144
Cutting for mounting (mm)	68 x 68	92 x 92	138 x 138	68 x 68	92 x 92	138 x 138
	scale 90°			scale 240°		
Scale length (mm)	63	95	135	113	135	220
Voltage input* Current input	100 V, 110 V, 230 V, 400 V 1 A, 5 A					
1b single phase system	•	•	•	•	•	•
3b three-phase three-wire system with balanced load	•	•	•	•	•	•
3u three-phase three-wire system with unbalanced load	•	•	•	•	•	•
4b three-phase four-wire system with balanced load	•	•	•	•	•	•
4u three-phase four-wire system with unbalanced load	•	•	•	•	•	•
<b>Option</b>						
Separated AC auxiliary supply 57 V, 63.5 V, 100 V, 230 V, 400 V	-	•	•	-	•	•

Class 1 on request (only for 90 degree dials). Self-consumption of current circuits approx. 0.1 VA and voltage circuits 0.2 VA.

\* Max. voltage input for EQ 0307, EQ 2307 for 3u, 3b: 150 V/250 V AC

\* Max. voltage input for EQ 0307, EQ 2307 for 4u, 4b, 1b: 230 V/400 V AC

\*\* Overloads of short duration on page 230.

Ship version meters EQ0207, EQ0107 are available on request.

Dimensional drawings on pages 77-79.  
Connection diagrams on pages 93.

# Analogue Meters

## POWER FACTOR METERS



YQ 0207



YQ 2207

Power factor meters are intended for measurement of power factor ( $\cos\varphi$ ) in a three-phase three-wire network with a balanced load of phases or in a single phase network. The accuracy class is 1.5.

### SCALE OUTLOOK

\* For meters: YQ 2207, YQ 2107

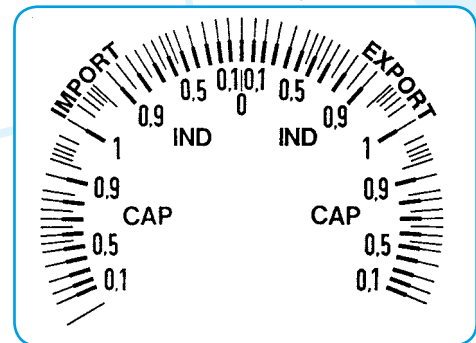

TYPE	YQ 0307	YQ 0207	YQ 0107	YQ 2307	YQ 2207	YQ 2107
Front frame (mm)	72 x 72	96 x 96	144 x 144	72 x 72	96 x 96	144 x 144
Cutting for mounting (mm)	68 x 68	92 x 92	138 x 138	68 x 68	92 x 92	138 x 138
	scale 90°			scale 240°		
Scale length (mm)	63	95	135	113	135	220
Voltage input*	100 V, 110 V, 230 V, 400 V, 500 V					
Current input	1 A, 5 A					
MEASURING RANGE	0.5 cap. ...1...0.5 ind. 0.8 cap...1...0.3 ind.					
1b Single phase system	•	•	•	•	•	•
3b Three-phase three-wire balanced load system	•	•	•	•	•	•
3u Three-phase three-wire unbalanced load system	•	•	•	•	•	•
4b Three-phase four-wire balanced load system	•	•	•	•	•	•
4u Three-phase four-wire unbalanced load system	•	•	•	•	•	•
MEASURING RANGE	import 0.1 cap. ... 1 ... 0 ind. 0 ...1... 0.1 cap. export					
<b>Option:</b>						
Separated AC auxiliary supply 57 V, 63.5 V, 100 V, 110 V, 230 V, 400 V	-	•	•	-	•	•

Ship version meters YQ 0207 are available on request.

\*Max. voltage input for YQ 0307, YQ 2307 for 3u, 3b: 150 V/250 V AC

\*Max. voltage input for YQ 0307, YQ 2307 for 4u, 4b, 1b: 230 V/400 V AC

Dimensional drawings on pages 77-79.

Connection diagrams on pages 93.

# Analogue Meters

## POINTER FREQUENCY METERS

Pointer frequency meters are intended for measurement of frequencies in the range from 45 Hz to 65 Hz. Accuracy class is 0.5.

### SCALES IN FULL-SIZE

For meters: ZQ 2x07

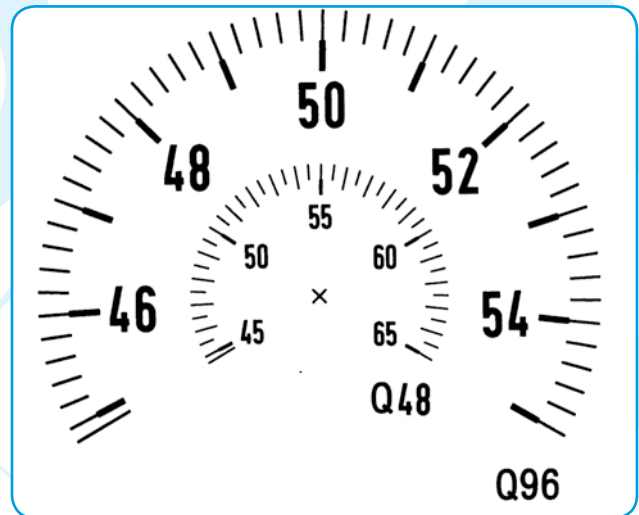

TYPE	ZQ 0507	ZQ 0407	ZQ 0307	ZQ 0207	ZQ 0107	ZQ 2307	ZQ 2207	ZQ 2107	
Front frame (mm)	45 x 45	48 x 48	72 x 72	96 x 96	144 x 144	72 x 72	96 x 96	144 x 144	
Cutting for mounting (mm)	-	45 x 45	68 x 68	92 x 92	138 x 138	68 x 68	92 x 92	138 x 138	
	scale 90°				scale 240°				
Scale length (mm)	41	41	65	95	135	101	135	220	
<b>MEASURING RANGE</b>	Voltage (V)								
45...55 Hz	57, 63, 100, 110, 230, 400, 500	•	•	•	•	•	•	•	
55...65 Hz	57, 63, 100, 110, 230, 400, 500	•	•	•	•	•	•	•	
48...52 Hz	57, 63, 100, 110, 230, 400, 500	•	•	•	•	•	•	•	
45...65 Hz	57, 63, 100, 110, 230, 400, 500	•	•	•	•	•	•	•	

Other ratings are available on request!  
Ship version of the meters ZQ 0307, ZQ 0207, ZQ 0107 are available on request.

Two-system frequency meters ZQ 1207, ZQ 1208 are on page 42.  
Dimensional drawings are on pages 77-79.

### DETAIL ONLY

For meters: ZQ 0x07

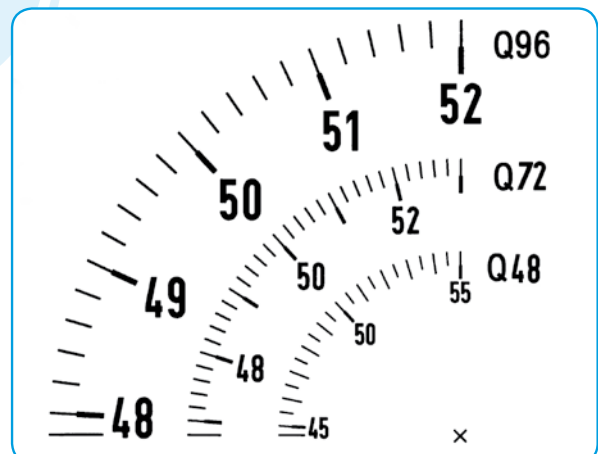

# Analogue Meters

## REED FREQUENCY METERS

**Reed frequency meters** are intended for measurement of frequencies in the range from 45 Hz to 65 Hz. The accuracy class is 0.5



ZQ 0217

TYPE			ZQ 0317	ZQ 0217	ZQ 0117
Front frame (mm)			72 x 72	96 x 96	144 x 144
Cutting for mounting (mm)			68 x 68	92 x 92	138 x 138
RATING	Voltage (V)	No. of reeds			
47...53 Hz	100, 110, 230	13	•	•	•
	400, 500		•	•	•
57...63 Hz	100, 110, 230	13	•	•	•
	400, 500		•	•	•
45...55 Hz	100, 110, 230	21		•	•
	400, 500			•	•
55...65 Hz	100, 110, 230	21		•	•
	400, 500			•	•

Self-consumption at 110-220 V range is 6...7 mA/system.

At other ranges it is 3...4 mA/system.

Ship version meters ZQ 0317, ZQ 0217 and ZQ 0117 are available on request.

Dimensional drawings on pages 77-79.

**Two-systems reed frequency meters** are intended for measurement of two frequencies in the system for synchronisation. Accuracy class is 0.5.

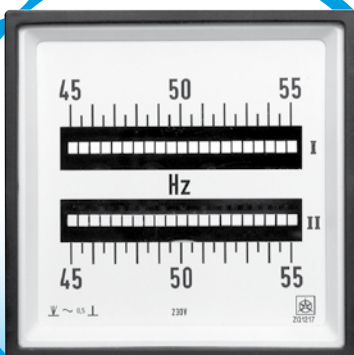

ZQ 1217

TYPE			ZQ 1217	ZQ 1117
Front frame (mm)			96 x 96	144 x 144
Cutting for mounting (mm)			92 x 92	138 x 138
RATING	Voltage (V)	No. of reeds		
2 x 47...53 Hz	100, 110, 230	2 x 13	•	•
	400, 500		•	•
2 x 57...63 Hz	100, 110, 230	2 x 13	•	•
	400, 500		•	•
2 x 45...55 Hz	100, 110, 230	2 x 21	•	•
	400, 500		•	•
2 x 55...65 Hz	100, 110, 230	2 x 21	•	•
	400, 500		•	•

Self-consumption at 110-230 V range is 6...7 mA/system.

At other ranges it is 3...4 mA/system.

Ship version meters ZQ 1217 and ZQ 1117 are available on request.

Dimensional drawings on pages 77-79.

# Analogue Meters

## METER WITH LIMIT CONTACT



MI 7350

MI 7350 can signal minimal and maximal setting limits (MIN and MAX). The meter is provided with two output relays of 600 VA switching power. Setting over or under the limits is displayed with a LED on the meter scale. DC or AC currents or voltages, frequency and temperature can be signalled.

TYPE		MI 7350
Front frame (mm)		96 x 96
Cutting for mounting (mm)		92 x 92
Scale length (mm)		95
MEASURED QUANTITY		
DC U	40...800 mV	•
	1...60 V	•
	100...600 V	•
AC U	100...800 mV	•
	6...60 V	•
	100...600 V	•
DC I	25...600 $\mu$ A	•
	1...60 mA	•
	100...600 mA	•
	1...5 A	•
AC I	1...6 mA	•
	100...600 mA	•
	1...5 A	•
	8 min. 1.2 A	–
	8 min. 6 A	–
AC Ief	100...600 mA	•
	1...5 A	•
	1/2 A, 1.5/3 A, 2.5/5 A	•
	4/8A, 5/10A	•
FREQUENCY f	45...55 Hz	•
	48...52 Hz	•
	45...65 Hz	•
	55...65 Hz	•
THERMOCOUPLE (J, K, S)	0...250°C	•
	0...600°C	•
	0...1200°C	•
	0...1600°C	•
TEMP. DEPENDENT RESISTOR PT100 (W)		•
	-200...+800°C	•
	$\Delta$ T...50°C min	•
		•

Standard supply 230 V AC; 24 V, 48 V, 60 V, 110 V DC on request.

Dimensional drawings on pages 77-79.

# Analogue Meters

## METERS FOR DC VOLTAGE OR CURRENT WITH MOVING COIL

Meters with a moving coil are intended for measurement of direct currents or voltages. A measuring system with a core magnet is not sensitive to external electromagnetic fields and is resistant to mechanical impacts and vibrations. The scale is entirely linear and interchangeable. The accuracy class is 1.5



TYPE	BQ 0507	BQ 0407	BQ 0307	BQ 0207	BQ 0107	BQ 2507	BQ 2407	BQ 2307	BQ 2207	BQ 2107
Front frame (mm)	45 x 45	48 x 48	72 x 72	96 x 96	144 x 144	45 x 45	48 x 48	72 x 72	96 x 96	144 x 144
Cutting for mounting (mm)	-	45 x 45	68 x 68	92 x 92	138 x 138	-	45 x 45	68 x 68	92 x 92	138 x 138
	scale 90°					scale 240°				
Scale length (mm)	41	41	63	95	140	71	71	113	155	235
RATING										
0-40 $\mu$ A...60 $\mu$ A	-	•	•	•	•	-	-	-	-	-
0-100 $\mu$ A...600 $\mu$ A	•	•	•	•	•	•	•	•	•	•
0-1 mA...600 mA	•	•	•	•	•	•	•	•	•	•
4...20 mA <sup>3)</sup>	•	•	•	•	•	•	•	•	•	•
0-1A...6A	•	•	•	•	•	•	•	•	•	•
0-10 A...25 A	-	•	•	•	•	-	•	•	•	•
0-40 A, 60 A	-	-	•	•	•	-	-	•	•	•
xA/60 mV <sup>1)</sup>	•	•	•	•	•	•	•	•	•	•
0-100 mV...600 mV	•	•	•	•	•	•	•	•	•	•
0-1V...600 V	•	•	•	•	•	•	•	•	•	•

### AMMETERS: RATINGS and INTERNAL RESISTANCES

#### BQ 0x07

$\mu$ A /  $\Omega$

40/5650, 60/4710, 100/2250, 150/1950, 250/990, 400/350, 600/150

#### BQ 2x07

$\mu$ A /  $\Omega$

100/5900, 150/5100, 250/4000, 400/2400, 500/1500, 600/1300

#### BQ 0x07

mA /  $\Omega$

1/65, 1.5/25, 2.5/11, 4/6, 5/4.5, 6/4, 10/2.6, 15/4, 20/3, 25/2.4, 40/1.5, 50/1.2, 60/1, 100/0.6, 150/0.4, 250/0.24, 400/0.15, 600/0.1

#### BQ 2x07

mA /  $\Omega$

1/370, 1.5/200, 2.5/780, 4/25, 5/8.4, 6/15, 10/7, 15/5, 20/3.9

mA: 25, 40, 50, 60, 100, 150, 250, 400, 600

- voltage drop on terminals approx. 60 mV

#### BQ 0x07, BQ 2x07

A<sup>2)</sup> : 1, 1.5, 2.5, 4, 6, 10, 15, 25, 40, 60

- voltage drop on terminals approx. 60 mV xA/60 mV<sup>2)</sup>

# Analogue Meters

## METERS FOR DC VOLTAGE OR CURRENT WITH MOVING COIL

### VOLTMETERS : RATINGS

#### BQ 0x07

mV<sup>2</sup>: 60, 100, 150 - 5 mA system

#### BQ 2x07

mV<sup>2</sup>: 60, 100, 150, 200, 300 - 5 mA system

#### BQ 0x07, BQ 2x07

V: 1, 1.5, 2.5, 4, 6, 10, 15, 25, 40, 6000, 150, 250, 400, 600 - 1 mA system

- characteristic resistance 1 k $\Omega$ /V

1) A meter for connection to a separate shunt, calibrated to resistance of connection terminals 0.035  $\Omega$ .

2) Current through a meter approx. 5 mA.

3) A version with electrical zero point suppression. A version with mechanical zero point suppression available on request.

Ship meter versions of BQ 0407 BQ 0307, BQ 0207, BQ 0107 available on request.

### SCALES IN FULL-SIZE

For meters: BQ 2x07  
CQ 2x07  
EQ 2207  
WQ 2207

BQ 0x07  
CQ 0x07  
EQ 0307, EQ 0207, EQ 0107  
WQ 0207  
KQ 0207, KQ 0307  
MI 7350

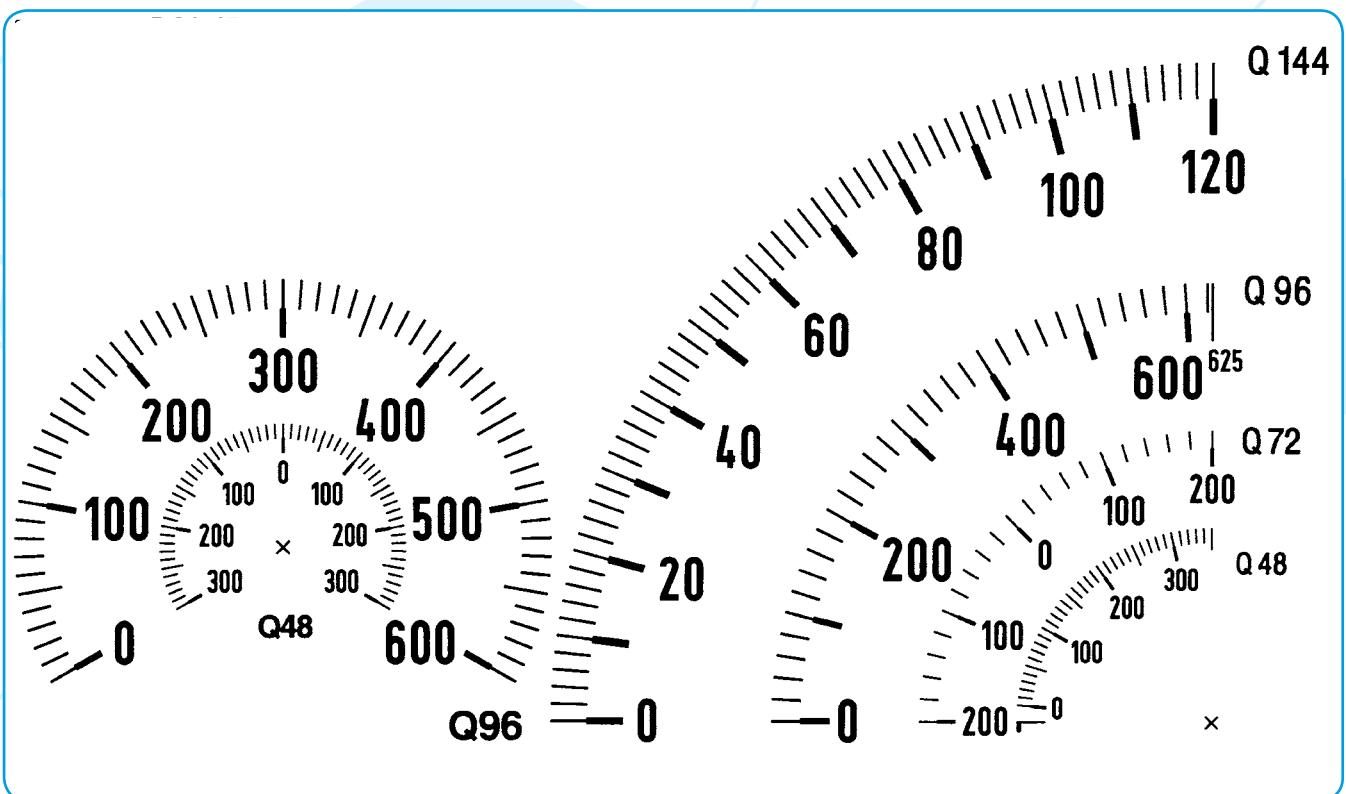

Special meters available on request; page 67.  
Dimensional drawings on pages 77-79.

# Analogue Meters

## TAP POSITION METERS WITH MOVING COIL

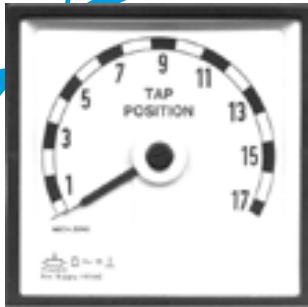

CQ 2207



CQ 0207

TAP meters with a moving coil are intended for measurement of tap position with auxiliary supply AC voltage. The position indicator monitors transformer tap position, hoist or valve position etc. It employs a bridge system. 1-2 positions can be provided using 400  $\Omega$  or 50  $\Omega$  per step. A measuring system with a core magnet is not sensitive to external electromagnetic fields. It is resistant to mechanical shocks and vibrations complying with EN 60051. The scale is entirely linear and interchangeable.

### FEATURES:

- For measurement of tap position
- Linear scale
- Interchangeable dial
- Resistant to mechanical vibrations and shocks
- Protective cover for terminal

### DIMENSIONS

TYPE	CQ 2207	CQ 0207
Front frame (mm)	96 X 96	96 x 96
Cutting for mounting (mm)	92 X 92	92 x 92
Scale	240°	90°
Scale length (mm)	155	95

Dimensional drawings on page 77.  
Connection diagrams on page 102.

# Analogue Meters

## METERS FOR AC VOLTAGE OR CURRENT WITH A MOVING COIL AND A RECTIFIER

Meters with a moving coil and a rectifier are intended for measurement of AC currents or voltages in the frequency range from 40 Hz to 65 Hz (higher frequency ranges on request) where low consumption of the meter is required. The meters measure a mean value of rectified current or voltage. The scale is expressed in rms values at sine form of the measured quantity. Distortion or deviation from the sine form for more than 1% entails additional errors. The scale is interchangeable. The accuracy class is 1.5.



TYPE	CQ 0507	CQ 0407	CQ 0307	CQ 0207	CQ 0107	CQ 207*	CQ 2507	CQ 2407	CQ 2307	CQ 2207**	CQ 2107
Front frame (mm)	45 x 45	48 x 48	72 x 72	96 x 96	144 x 144	96 x 96	45 x 45	48 x 48	72 x 72	96 x 96	144 x 144
Cutting for mounting (mm)	-	45 x 45	68 x 68	92 x 92	138 x 138	92 x 92	-	45 x 45	68 x 68	92 x 92	138 x 138
	scale 90°						scale 240°				
Scale length (mm)	41	41	63	95	140	95	71	71	113	155	235
RATING											
0-100 µA...600 µA	•	•	•	•	•	-	•	•	•	•	•
0-1 mA...10 mA	•	•	•	•	•	-	•	•	•	•	•
xA/1A, xA/5A <sup>1)</sup> (max. 7.5 A)	•	•	•	•	•	•	•	•	•	•	•
0-2.5 V...500 V	•	•	•	•	•	-	•	•	•	•	•
0-600 V	•	•	•	•	•	-	•	•	•	•	•

\*CQ 3207 4-stage selector switch is built in the meter for measurement of current in three individual phases. At current switch-over the circuit is not interrupted.

\*\* Overloads of short duration on page 104.

### AMMETERS: RATINGS

µA: 100, 150, 250, 400, 500, 600

mA: 1, 1.5, 2.5, 4, 5, 6, 10

Voltage drop approx. 1,5 V

A/Voltage drop (V) x/1 A – 0.1 V, x/5 A – 0.03 V

### VOLTMETERS: RATINGS

V: 2.5, 4, 6, 10, 15, 25, 40, 60, 100, 150, 250, 400, 500, 600

- characteristic resistance 1 kΩ/V

1) Meters for connection to a current measuring transformer. Special versions of the meters available on request; page 67.

2) Connection diagram and dimensional drawing of transformer for CQ 0407, CQ 2407 on page 79 and CQ 3207 on page 103.

Dimensional drawings on pages 77-79.

# Analogue Meters

## METERS FOR DC AND AC VOLTAGE OR CURRENT WITH MOVING COIL



BN 0103, CN 0103

Owing to a special form and available colours, BN and CN meters are especially convenient for building into different control devices. The accuracy class is 1.5. The scale is not interchangeable. BN meters are intended for DC currents or voltages, and CN meters for AC currents or voltages.

TYPE	BN 0103	BN 0203	CN 0103	CN 0203
Front frame (mm)	86 x 72	115 x 96	86 x 72	115 x 96
Cutting for mounting (mm)	φ 65	φ 65	φ 65	φ 65
Scale length (mm)	60	90	60	90
<b>RATING</b>				
0-40 μA...60 μA	•	•	-	-
0-100 μA...600 μA	•	•	•	•
0-1 mA...10 mA	•	•	•	•
0-15 mA...600 mA	•	•	-	-
4...20 mA <sup>3)</sup>	•	•	-	-
0-1 A...6 A	•	•	-	-
0-10 A...25 A	•	•	-	-
0-40 A, 60 A	•	•	-	-
xA / 1A, xA / 5A <sup>2)</sup>	-	-	•	•
xA / 60 mV <sup>1)</sup>	•	•	-	-
0-100 mV...600 mV	•	•	-	-
0-1 V...600 V	•	•	•	•

- 1) A meter for connection to a separate shunt.  
 2) A meter for connection to a current measuring transformer.  
 3) A version with electrical zero point suppression.  
 A version with mechanical zero point suppression available on request.

### AMMETERS: RATINGS & INTERNAL RESISTANCE

BN 0103, BN 0203
A / Ohm: 40/5650, 60/4710, 100/2250, 150/1950, 250/990, 400/350, 600/150
A <sup>1)</sup> : 1, 1.5, 2.5, 4, 6, 10, 15, 25, 40, 60
Voltage drop on terminals approx. 60 mV
CN 0103, CN 0203
μA: 100, 150, 250, 400, 500, 600
mA: 1, 1.5, 2.5, 4, 5, 6, 10
Voltage drop approx. 1.5 V
A / Voltage drop (V) x/1A-0,1 V, x/5A-0.03 V

Dimensional drawings on page 78.

### VOLTMETERS: RATINGS

BN 0103, BN 0203
mV <sup>1)</sup> : 60, 100, 150 - 5 mA system
V: 1, 1.5, 2.5, 4, 6, 10, 15, 25, 40, 60, 100, 150, 250, 400, 600 - 1 mA system
- characteristic resistance 1 k Ohm/V
CN 0103, CN 0203
V: 2.5, 4, 6, 10, 15, 25, 40, 60, 100, 150, 250, 400, 500, 600
- characteristic resistance 1 kOhm/V

1) Current through a meter approx. 5 mA.

# Analogue Meters

## METERS FOR AC VOLTAGE OR CURRENT WITH MOVING IRON

Meters with a moving iron are intended for measurement of AC currents or voltages of frequencies from 15 Hz to 100 Hz. They measure rms values independently on the signal form of current or voltage. The accuracy class is 1.5. As the beginning of the scale is non-linear, reading from 15% of rating onwards is possible. Ammeters with rating for double, triple or even six-time value of rated current are available on request. The overload range is extremely non-linear. The scale is interchangeable



TYPE	FQ 0507	FQ 0407	FQ 0307	FQ 0207**	FQ 0107	FQ 3307	FQ 3207*	FQ 3107*	FN 0103*	FN 0201*
Front frame	45 x 45	48 x 48	72 x 72	96 x 96	144 x 144	72 x 72	96 x 96	144 x 144	86 x 72	115 x 96
Cutting for mounting (mm)	-	45 x 45	68 x 68	92 x 92	138 x 138	68 x 68	92 x 92	138 x 138	φ 65	φ 65
scale 90°										
Scale length (mm)	41	41	63	95	140	63	95	140	60	60
RATING										
0-100 mA...600 mA	•	•	•	•	•	-	-	-	•	•
0-1 A...10 A	•	•	•	•	•	-	-	-	•	•
0-15 A, 25 A	•	•	•	•	•	-	-	-	•	•
0-40 A	-	-	•	•	•	-	-	-	•	•
0-60 A	-	-	•	•	•	-	-	-	•	•
x A/1 A, x A/5 A	•	•	•	•	•	-	-	-	•	•
WITHOUT DIAL xA/1A, xA/5 A	•	•	•	•	•	-	-	-	-	-
0-6 V...600 V	•	•	•	•	•	•	•	•	•	•
xV/100 V, xV/110 V	•	•	•	•	•	•	•	•	•	•

FQ 3107, FQ 3307 are intended for measurement of phase and line-to-line voltages in three-phase system. Required phase or line-to-line voltage or current is selected with a selector switch.

\*A dial is not interchangeable

\*\*Overloads of short duration on page 104.

# Analogue Meters

## METERS FOR AC VOLTAGE OR CURRENT WITH MOVING IRON

### AMMETERS: RATINGS

mA 100, 150, 200, 250, 300, 400, 500, 600

A 1, 1.5, 2.5, 4, 6, 10, 15, 25, 40, 60

A xA/1A, xA/5A

- for connection to a current measuring transformer

### VOLTMETERS: RATINGS

V 6, 10, 15, 25, 40, 60, 100, 150, 250, 300, 400, 500, 600

V .../100, .../110

- for connection to a voltage measuring transformer

Self-consumption for: - ammeters: from 0.3 VA to 1.2 VA

x/1A ...0.4 VA

x/5A ...0.7 VA

- voltmeters: from 1.2 VA to 4 VA

Meters for connection to a measuring transformer have the following standard ratings: 1 - 1.2-1.5-2-2.5-3-4-5-6-7.5 (8) and decade multiples.

Ship version meters FQ 0407, FQ 0307, FQ 0207, FQ 0107 available on request.

Special version meters available on request; on page 67.

### SCALES IN FULL SIZE FOR METERS: FQ 0x07

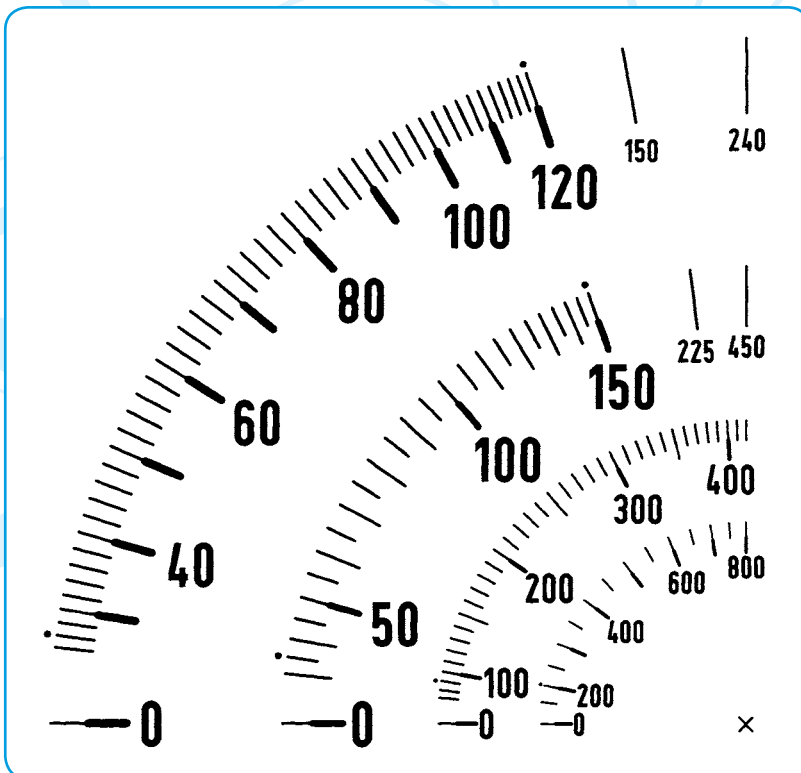

2 times overload

3 times overload

Dimensional drawings on pages 77-79.

Connection diagram for FQ 3107, FQ 3207, FQ 3307 on page 103.

# Analogue Meters

## BIMETAL MAXIMUM CURRENT METERS



MQ 0507



MQ 0207

Bimetal maximum current meters with a bimetal measuring system are intended for testing thermal load of transformers, cables, electrical machines, etc. They indicate average rms current value in an 8 minutes setting period (on request 15, 20 and 30 minutes for MQ 0207 and MQ 0307).

The accuracy class is 3. The meters are provided with an interchangeable scale.

Meters 96 x 96 mm with a protecting transformer are also available on request.

TYPE	MQ 0507	MQ 0407	MQ 0307	MQ 0207	MQ 0107
Front frame (mm)	45 x 45	48 x 48	72 x 72	96 x 96	144 x 144
Cutting for mounting (mm)	-	45 x 45	68 x 68	92 x 92	138 x 138
scale 90°					
Scale length (mm)	37	37	63	95	140
<b>RATING</b>					
1.2 A, x A/1 A <sup>1)</sup> 8 min. *	•	•	•	•	•
6 A, x A/5 A <sup>1)</sup> 8 min. *	•	•	•	•	•

\* Other setting period (15, 20 and 30 minutes) on request.

1) The rating is 20% higher than the current transformer ratio.  
Self-consumption: 1.2 VA at 1.2 A; 2.2 VA at 6 A.

Dimensional drawings on pages 77-79.

### SCALE IN FULL-SIZE

For meters: MQ 0207

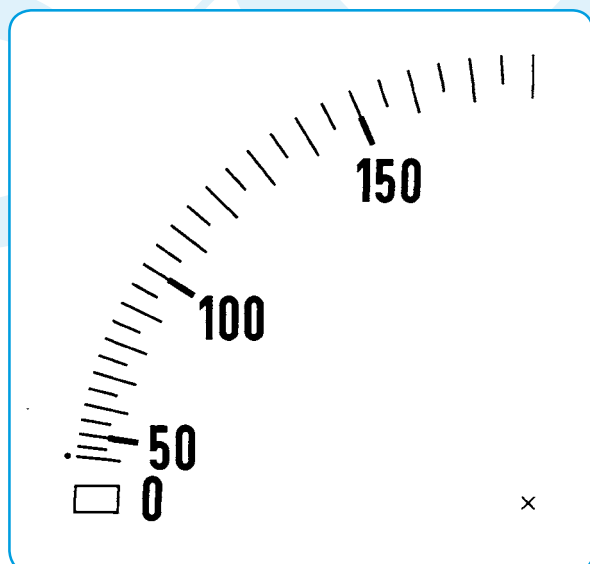

150/5 A - 180 A

# Analogue Meters

## COMBINED BIMETAL MAXIMUM CURRENT METERS



MQ 0217

Combined bimetal maximum current meters are provided with a built-in bimetal system and a system with a moving iron. The meters are intended for testing momentary and thermal load of transformers, cables, electrical machines, etc. Meters 96 x 96 mm with a protecting transformer are also available on request.

The accuracy class for average rms current value is 3, and for momentary value 1.5. The meters are provided with an interchangeable scale.

### SCALES IN FULL-SIZE

For meters: MQ 0207

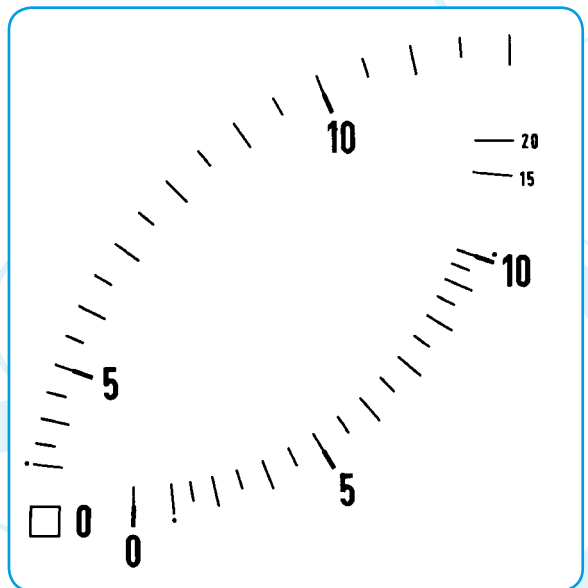

10/5 A

TYPE	MQ 0317	MQ 0217	MQ 0117
Front frame (mm)	72 x 72	96 x 96	144 x 144
Cutting for mounting (mm)	68 x 68	92 x 92	138 x 138
Scale length (mm)	63/43	95/72	140/120
RATING			
1.2 A x A/1 A* 8 min.	•	•	•
6 A x A/5 A* 8 min.	•	•	•

\*Rating of average current is 20% higher than the current transformer ratio.

The meter for a momentary value can indicate either 20% or 100% overload.

Self-consumption: 1.8 VA at 1.2 A; 2.8 VA at 6 A.

Other setting period (15, 20 and 30 minutes) on request.

Dimensional drawings on pages 77-79.

# Analogue Meters

## PHASE SEQUENCE INDICATOR SQ 0201 AND TEMPERATURE METERS



SQ 0201



KQ 0x07

**A phase sequence indicator** is intended for determining phase sequences in a three-phase network, from 200 V to 500 V and from 50 Hz to 60 Hz. The indicator is provided with two built-in glow lamps indicating L1, L2, L3 phase sequence.

**Temperature meters** are intended for connection to various thermocouples or temperature dependant resistors with the possibility of analogue output. The accuracy class is 1.5.

TYPE		KQ 0307	KQ 0307	KQ 0207	KQ 0207
Front frame (mm)		72 x 72	72 x 72	96 x 96	96 x 96
Cutting for mounting (mm)		68 x 68	68 x 68	92 x 92	92 x 92
Scale length (mm)		65	65	95	95
ANALOGUE OUTPUT		-	0...10 mA Rmax. = 200 Ω	-	0...10 mA Rmax. = 200 Ω
MEASURING RANGE					
Resistor probe Pt 100	+/-50°C	•	•	•	•
	0...100°C	•	•	•	•
	0...200°C	•	•	•	•
	0...300°C	•	•	•	•
	0...400°C	•	•	•	•
Thermocouple J Fe-CuNi	0...200°C	•	•	•	•
	0...400°C	•	•	•	•
	0...600°C	•	•	•	•
Thermocouple K NiCr-Ni	0...600°C	•	•	•	•
	0...800°C	•	•	•	•
	0...1200°C	•	•	•	•
Thermocouple S PtRh-Pt	0...1400°C	•	•	•	•
	0...1600°C	•	•	•	•

Supply: 230 V ∞ +/-10% (50...60 Hz)  
On request: KQ 0207, KQ 0307  
110 V +/-10% (50...60 Hz)

Other thermocouples on request.

Dimensional drawings on pages 77-79.

# Portable Meters

## MI 7033 ANALOGUE MULTIWATTMETER



MI 7033

An analogue multiwattmeter is used for direct measurement of DC power, voltage, current and active and reactive power, voltage, current,  $\cos\varphi$  and phase sequence in three-phase three-wire systems with uniform load and active power, voltage, current,  $\cos\varphi$  in single phase AC systems. The selection of current and voltage ratings meets the majority of requirements for power measurement in repair shops, production premises and in laboratories for fast and less accurate measurements.

Operation mode	TDM ( Time Division Multiplication)
Voltage inputs	50 V, 100 V, 250 V, 500 V
Current inputs	0.25 A, 1 A, 5 A, 25 A
Rating	12.5 W...25,000 W
Frequency range	10...16...65...400 Hz
Accuracy class	power: 1.5
	voltage, current: 2.5
	$\cos\varphi$ : 5
Dimensions	110 x 181 x 62 mm
Supply	2 x 9V IEC 6F22
Weight with packing	700 g

# Portable Meters

## MULTIMETERS



MI 7065

Due to electric and constructional features the analogue and digital universal meters are intended for a wide range of users. They are especially convenient for repair shops, electric, radio and electronic professions as well as for the field work. Ratings are protected against overloads when the meters are connected to 250 V.

TYPE		MI 7054	MI 7056	MI 7065
Voltage	=	30 V ... 600 V	100 mV ... 600 V	100 mV-300 V
	~	30 V ... 600 V	10 V ... 600 V	3 V-300 V
Current	=	0.3 A ... 15 A	50 $\mu$ A ... 1A	100 $\mu$ A-3 A
	~	0.3 A ... 15 A	3 mA ... 3 A	100 $\mu$ A-3 A
Characteristic resistance	=	1.45 k $\Omega$ /V	20 k $\Omega$ /V	10 M $\Omega$
	~	1.33 k $\Omega$ /V	6.67 k $\Omega$ /V	10 M $\Omega$
Number of ratings		15	24	25
Resistance	$\Omega$ x	1, 10, 100	1,10,100	-
Level dB		-	•	-
Polarity indication		-	-	-
Accuracy		2.5 $\cong$	2.5 $\cong$	3 $\infty$
				2 $\cong$
Special features		Full protection	-	Zero in the middle of the scale
Supply		1 x 1.5 V R6	1 x 1.5 V R6	1 x 9 V 6F22
Dimensions (mm)		102 x 142 x 40	102 x 142 x 40	96 x 132 x 33
Weight with packing		470 g	340 g	400 g

# Portable Meters

## EDUCATIONAL PROGRAMME

Portable meters for schools are indispensable for exercises in physics and practical work. The meters enable a wide range of measurements and are adapted for pupils' work. They excel in a high degree of protection against overloads, user-friendly application as well as an accurate readout and extremely high reliability.



07035.00

TYPE	07035.00	07036.00	07037.00	07038.00	07039.00	07027.01	07021.01	07026.00	
Type of measurement	Voltmeter	Ammeter	Voltmeter =	Ammeter =	Galvanometer =	Multimeter	Multimeter	Multimeter	
Voltage	=	0.3 V ... 300 V	60 mV	5/15 V	-	-	0.06 V ... 60 V	240 mV ... 600 V	0.1 V ... 1000 V
	~	10 V ... 300 V	-	5/15 V	-	-	6 V ... 60 V	6 V ... 600 V	1 V ... 1000 V
Current	=	-	1 mA 3 A	-	1/5 A	3.5 mA	100 $\mu$ A ... 6 A	0.12 mA 6 A	0.1 mA ... 10 A
	~	-	1 mA 3 A	-	1/5 A	3.5 mA	6 mA ... 6 A	6 mA ... 6 A	1 mA ... 10 A
Resistance ( $\Omega$ x)	-	-	-	-	-	-	-	1,10,100	
Level (dB)	-	-	-	-	-	-	-	-10...+12	
Input resistance	=	30 k $\Omega$ /V	-	1 k $\Omega$ /V	-	-	10 k $\Omega$ /V	10 k $\Omega$ /V	12 k $\Omega$ /V
	~	10 k $\Omega$ /V	-	-	-	-	4 k $\Omega$ /V	4 k $\Omega$ /V	4 k $\Omega$ /V
Accuracy	2.5 $\cong$	2.5 $\cong$	1.5	1.5	1.5	2.5 $\cong$	1.5= 2.5 $\infty$	1.5= 2.5 $\infty$	
Frequency range	15 Hz ... 10 kHz	-	-	-	-	15 Hz ... 11 kHz	20 Hz ... 10 kHz	15 Hz ... 11 kHz	
Special features	-	-	Scale with a mirror	Scale with a mirror	Zero point in the middle of the scale	Zero point in the middle of the scale	Scale with a mirror	Scale with a mirror	
Supply	-	-	-	-	-	-	-	2 x 1.5 V R6	
Dimensions (mm)	100 x 165 x 55								
Weight with packing	360 g	430 g	290 g	280 g	270 g	520 g	550 g	520 g	

# Portable Meters

## MI 7022 DIGITAL TEMPERATURE METER

It has a 3 1/2-digit display and is appropriate for measuring of foodstuffs by the HACCP system. By means of appropriate Pt100 sensors, temperature can be measured from:

- -50°C to +200°C.
- Error: < 0.2° K
- Dimensions: 135 x 69 x 28 mm
- Supply: 2 x 1.5 V LR03



TYPE OF TEMPERATURE SENSORS FOR MI 7022	
Application range	-50°C...+ 200°C.
Sensor	Pt 100, conforms standard IEC-751, error 1/3 B
Dimensions of the tip part	φ 3 mm x 150 mm
<b>We produce two types of sensors:</b>	
<b>AT0621</b> for direct connection to the measuring device	

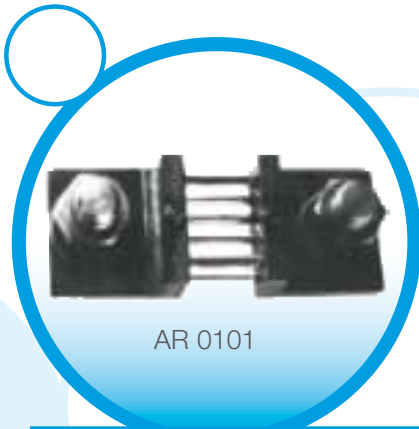

AR 0101

### SEPARATE SHUNTS

Separate shunts increase DC current ratings when connected with the meter with a moving coil. Voltage drop is 60 mV. Connection wires with  $0.035 \Omega$  resistance are enclosed to the shunt. Dimensions comply with DIN 43703. The accuracy class is 0.5.

RATED CURRENT (A)/60 mV	MASS (kg)
1, 1.5	0.18
2.5, 4, 6, 10, 15, 25	0.20
40, 60, 100, 150	0.14
250	0.55
400	0.80
600	0.84
1000	1.50
1500	2
2500	3

Other ratings and voltage drops are available on request.

### SHUNTS FOR ADD-ON

Dimensions of shunts are adapted to meter connection contacts and can be easily fixed with M4 screws. The basic meter is provided with the measuring system 5 mA and measures voltage drop 60 mV.

Only a corresponding scale has to be inserted. The shunts can be used on the housings 96 x 96 mm and 72 x 72 mm, and BN 0103 and BN 0203 meters. The accuracy class is 0.5.

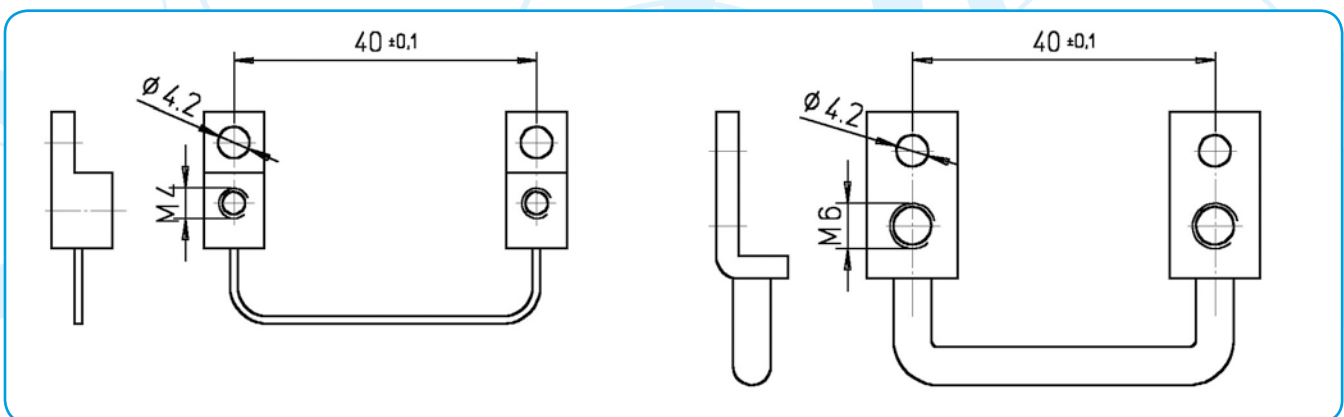

AR 0105

RATED CURRENT (A)/60 mV
1, 1.5, 2, 2.5, 4, 5, 6, 8, 10, 15, 20

Dimensional drawings on page 86.

# Equipment and Accessories

## CURRENT MEASURING TRANSFORMERS



ASK 31,5



ASK 61,4

Current measuring transformers are used for measuring AC currents. Secondary current is 5 A, rated frequency from 50 Hz to 60 Hz. The accuracy class is 1.

TYPE	POWER	I prim/5 A	Primary cable
ASR 20.3	1 VA.. 7.5 VA	50 A.. 300 A	ø 21 mm
ASR 201.3	1 VA.. 7.5 VA	50 A.. 300 A	ø 21 mm
ASR 21.3	1 VA.. 10 VA	100 A.. 600 A	ø 22.5 mm
ASR 22.3	1 VA.. 15 VA	40 A..600 A	ø 22.5 mm
ASR 22.3 2U	2.5 VA..10 VA	100 A..600 A	ø 22.5 mm
ASK 205.3	1 VA..10 VA	60 A.. 400 A	20 x 5 mm, ø 17.5 mm
ASK 21.3	1 VA.. 15 VA	40 A.. 600 A	20 x 10 mm, ø 19.2 mm
ASK 231.5	1 VA.. 15 VA	50 A.. 600 A	30 x 10 mm, ø 28 mm
ASK 31.3	1 VA.. 10 VA	50 A.. 750 A	30 x 10 mm, 2 x 20 x 10 mm, ø 26 mm
ASK 31.3 2U	2.5 VA..15 VA	100 A..600 A	30 x 10 mm, 2 x 20 x 10 mm, ø 26 mm
ASK 318.3	1 VA.. 15 VA	60 A.. 750 A	31 x 18 mm, ø 26 mm
ASK 31.4	1.25 VA.. 15 VA	50 A.. 750 A	30 x 10 mm, 2 x 20 x 10 mm, ø 28 mm
ASK 31.4 2U	2.5 VA.. 15 VA	100 A.. 600 A	30 x 10 mm, 2 x 20 x 10 mm, ø 28 mm
ASK 31.4 3U	2.5 VA.. 15 VA	100 A.. 600 A	30 x 10 mm, 2 x 20 x 10 mm, ø 28 mm
*ASK 31.5	1 VA.. 30 VA	40 A.. 750 A	30 x 10 mm, 2 x 20 x 10 mm, ø 28 mm
ASK 31.5 2U	2.5 VA.. 15 VA	75 A.. 600 A	30 x 10 mm, 2 x 20 x 10 mm, ø 28 mm
ASK 41.3	1 VA.. 15 VA	100 A.. 800 A	40 x 12 mm, 32 x 18 mm, ø 26 mm
ASK 421.4	1 VA.. 30 VA	30 A.. 500 A	20 x 10 mm, ø 20 mm
ASK 41.4	1.25 VA.. 30 VA	50 A.. 1000 A	40 x 10 mm, 2 x 30 x 5 mm, ø 32 mm
ASK 41.4 2U	2.5 VA.. 15 VA	100 A.. 1000 A	40 x 10 mm, 2 x 30 x 5 mm, ø 32 mm
ASK 41.4 3U	2.5 VA.. 15 VA	100 A.. 1000 A	40 x 10 mm, 2 x 30 x 5 mm, ø 32 mm
ASK 412.4	1.25 VA.. 30 VA	50 A.. 800 A	40 x 10 mm, 30 x 15 mm, ø 30,5 mm
ASK 541.4	1 VA.. 30 VA	30 A.. 1000 A	40 x 10 mm, 2 x 30 x 5 mm, ø 32 mm
ASK 51.4	1.5 VA.. 30 VA	100 A.. 1250 A	50 x 12 mm, 2 x 40 x 10 mm, ø 44 mm
ASK 51.4 2U	2.5 VA.. 30 VA	200 A.. 1200 A	50 x 12 mm, 2 x 40 x 10 mm, ø 44 mm
ASK 51.4 3U	2.5 VA.. 15 VA	200 A.. 1200 A	50 x 12 mm, 2 x 40 x 10 mm, ø 44 mm
ASK 561.4	2.5 VA.. 30 VA	200 A.. 1250 A	60 x 10 mm, 2 x 50 x 10 mm, ø 44 mm
*ASK 61.4	1.5 VA.. 30 VA	200 A.. 1600 A	63 x 10 mm, 2 x 50 x 10 mm, ø 44 mm
ASK 61.4 2U	2.5 VA.. 30 VA	250 A.. 1600 A	63 x 10 mm, 2 x 50 x 10 mm, ø 44 mm
ASK 61.4 3U	2.5 VA.. 15 VA	200 A.. 1600 A	63 x 10 mm, 2 x 50 x 10 mm, ø 44 mm
ASK 63.4	1.5 VA.. 15 VA	300 A.. 2000 A	60 x 30 mm, 50 x 40 mm, ø 44 mm
ASK 63.6	1.5 VA.. 30 VA	200 A.. 2000 A	60 x 30 mm, ø 30 mm
ASK 81.4	2.5 VA.. 45 VA	400 A.. 2000 A	80 x 10 mm, 60 x 30 mm, 2 x 60 x 10 mm, ø 55 mm
ASK 81.4 2U	5 VA.. 30 VA	500 A.. 2000 A	80 x 10 mm, 60 x 30 mm, 2 x 60 x 10 mm, ø 55 mm
ASK 101.4	5 VA.. 45 VA	500 A.. 2500 A	100 x 10 mm, 2 x 80 x 10 mm, ø 70 mm
ASK 101.4 2U	5 VA.. 30 VA	600 A.. 2500 A	100 x 10 mm, 2 x 80 x 10 mm, ø 70 mm
ASK 103.3	5 VA.. 45 VA	750 A.. 3000 A	2 x 100 x 10 mm, 3 x 80 x 10 mm, ø 85 mm
ASK 123.3	5 VA.. 45 VA	1000 A.. 4000 A	123 x 30 mm, 3 x 100 x 10 mm, ø 100 mm
ASK 129.10	5 VA.. 45 VA	1000 A.. 7500 A	120 x 90 mm
WSK 30	2.5 VA.. 5 VA	1 A.. 20 A	-
WSK 40	2.5 VA.. 15 VA	1 A.. 40 A	-
WSK 60	2.5 VA.. 15 VA	5 A..30 A	-
WSK 70.6	2.5 VA.. 15 VA	25 A..150 A	-

Snap-on mounting for ASK type

Other ratings and accuracy classes by agreement.

\* on stock ASK 31.5 2.5 VA 50, 75 A; 5 VA 100-600 A, ASK 61.4 10 VA 800, 1000, 1200, 1500 A

# Special Demands

It is technically not possible to satisfy all the below stated special requirements at each standard version. A previous agreement is therefore required.

## **General**

- Increased mechanical resistance
- Non-brilliant pane
- Mechanically resistant pane (plastic)
- Front frame in another colour (red, blue, yellow)
- Tropical version in compliance with DIN 40040 -
  - mechanical meters HVE
  - electronic meters JVE
- Adjustable pointer 1x
- Adjustable pointer 2x
- Protection of the front side IP 54
- Protection of the front side IP 65 (see page 79) • Ship version:
  - mechanical meters
  - electronic meters
- Luminescent scale (72x72 and 96x96 mm)
- DC supply 24 V, 48 V, 60 V
- DC supply 110 V, 230 V
- Non-standard mounting position
- Protection cover for protection of connection terminals:
  - Q144, Q96, Q72, Q48
- Spare fixing elements:
  - H1
  - mosaic fixing

## **Meters with moving coil**

- Zero point in the middle or at an optional position
- Non-standard rating
- Additional rating
- Non-standard internal resistance
- Built-in potentiometer for range extension
- Increased damping
- Increased accuracy (error 1%),
  - scale 90°
  - scale 240°
- Mechanical zero point suppression

## **Meters with moving iron**

- Non-standard rating
- Calibration for DC and AC quantity
- Increased damping
- Calibration for higher frequency (from 100 Hz to 500 Hz)
- Ammeters with 100% overload
- Ammeters with triple or multiple overload (max. 6 times)
- Additional ratings
- Increased accuracy (1% in one selected point)

## **Dial**

- Dial with a standard scale
- Dial with a non-standard scale
- Non-printed scale
- Scale by a table, a curve, a calibration
- Additional designations on a scale (max. 15 characters)
- Colour designation on a scale
- Colour field on a scale
- Non-standard scale division
- Black dial, white or yellow designations
- Transparent dial

## **Other meters and accessories**

- MQ.. with protecting transformer
- MQ../5A with setting times 15, 20 and 30 min.
- ZQ.. with another measuring range (16 2/3...400 Hz )
- Separate shunts with voltage drop 75 mV
- Separate shunts with voltage drop 100 mV
- Separate shunts with accuracy 0.2%

# General Explanations

## Interchangeable scale at panel meters

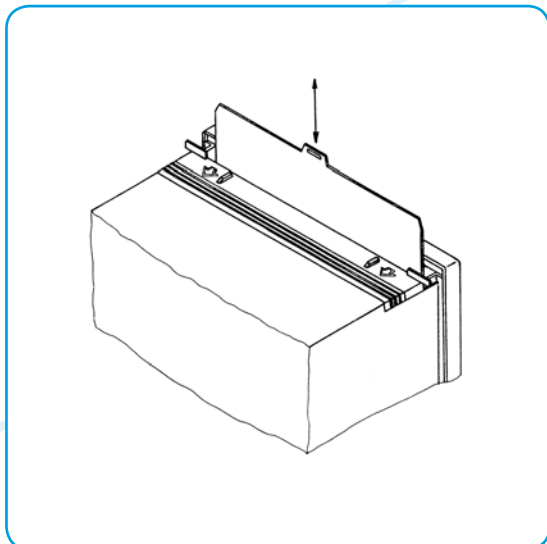

Scales can be interchanged at square panel meters and at meters for rail mounting (35 mm) with digit 7 at the end of a type designation (e.g. FQ 0207) both at new and already used instruments. This is especially convenient for the meters which are connected to a current or voltage measuring transformer or a shunt. Push a cover towards the upper part in the direction of an arrow and draw out the scale with a suitable tool. When the scale is replaced, carefully close the slot with the cover. The scale colour complies with RAL 9010.

## Ship version

Special versions are available for panel mounting into ships. These are mechanically resistant and additionally sealed meters which comply with the requirements of CRS (Croatian Register of Shipping Co. Ltd). The meter housing is marked with an anchor  and L is added to the type designation. (e. g. FQ 0207L)

## Housing

All square panel meters which comply with DIN 43700 are made of mechanically and temperature resistant dark grey (RAL 9011) thermoplastic material; incombustibility complies with UL 94 V-0. The black (RAL9005) front frame complies with DIN 43718. At customer request a special cover for the protection of connection terminals from contact can be added to the meter (IP20).

## Pointer

At square meters the pointer is a standard type with a narrowed point. Sensitive meters and multimeters are provided with a tube or a narrowed tube pointer.

standard pointer



tube pointer



knife-edge pointer



# General Explanations

## **Fixing**

The panel meters are fixed to the switchboard with the enclosed fixing elements:

- the Q square meters are usually fixed with screws (figure on page 78).
- by agreement, the meters (48 mm x 48 mm) can be fixed with special fixing elements for two versions of mosaic mounting (see page 78).

## **Degree of protection**

A type of protection complies with DIN 40050: for a housing IP 52 and for connection terminals IP 00.

IP20 with protection cover (optional)

IP54 protection provides for additional sealing of the front side (optional).

IP65 with silicon protection cover (optional, see page 79).

## **Accuracy**

The accuracy class according to EN60051 indicates permitted deviation in percentage from the final measuring value and is stated for each group separately.

## **Temperature and climatic conditions**

Standard meters operate in the ambient temperature range from -25°C to 55°C. Max. relative humidity is 80%.

According to IEC 60721-2-1 (Classification of environmental conditions) our instruments comply with WDaE type of climate. For more difficult ambient conditions when slight dampening (but no moulds) occurs, a special “conditionally tropic” version is available: HVE (from -25°C to +55°C) for standard meters without electronics and JVE (from -10°C to +55°C) for the meters with built-in electronics.

## **Resistance to vibrations and shocks**

Resistance to vibrations and shocks of analogue panel meters complies with EN 60051 or DIN VDE 0410/3.86 standard.

# General Explanations



















## Position and marks

Normal operating position of the panel meters is vertical. The position is marked on the scale and the meters are correspondingly calibrated.

- ⊥ vertically
- horizontally
- ∠ $\alpha^\circ$  at an angle (e.g. 60° regarding the horizontal position)

## OTHER SYMBOLS ON THE SCALE AND THE HOUSING COMPLY WITH EN60051 AND EN61010.

Significance of symbols

	Measuring system with a moving coil
	Measuring system with a moving coil
	Measuring system with a moving iron
	Bimetal measuring system
	Combined meter with a bimetal
	system and a moving iron
	Meter with electronics
	Vibrating measuring system
	Terminal for a protective conductor
	Warning: see Application Instructions
	Test voltage not compliant with VDE
	DC
	AC
	DC and AC
	Three phase three-wire system with balanced load
	Three-phase four-wire system with balanced load
	Three phase three-wire system with unbalanced load (two measuring systems)
	Three-phase four-wire system with unbalanced load (three measuring systems)
	Accuracy class

## Ratings in compliance with DIN 43780

Standard ratings are selected from the sequence 1-1.2-1.5-2.5-3-4-5-6-7.5-(8) also considering decade multiples of the stated numbers. Units on the scale are marked according to DIN 1301.

# General Explanations

## GENERAL DATA

FORM	Type of measurement	U,I	U,I	U,I	I	I	f	f	P	W	cos φ	T			Page in catalogue
	Symbol of measuring system														

Type of meter		U,I	U,I	U,I	I	I	f	f	P	W	cos φ	T	Ship version	Interchangeable dial	Page in catalogue	
	BQ 0...	•											•	•	176, 177	
	FQ 0...			•									•	•	181, 182	
	MQ 0...				•	•								•	183, 184	
	CQ 0...		•											•	179	
	ZQ 0...							•						•	•	173
	YQ 0...										•			•	•	172
	EQ 0...								•					•	•	171
	WQ 0...								•							170
	MI 7350	•	•	•	•	•			•						•	175
	KQ 0...												•		•	185
	BQ 2...	•												•	176, 177	
	CQ 2...		•											•	179	
	ZQ 2...							•						•	173	
	YQ 2...										•			•	172	
	EQ 2...								•					•	171	
	FQ 1...			•									•	•	169	
	ZQ 1...							•					•	•	169	
	ZQ..17							•					•	•	174	
	BN 0...	•													180	
	FN 0...			•											181	
	CN 0...		•												180	
	BQ 0507	•												•	176, 177	
	FQ 0507			•										•	181, 182	
	MQ 0507				•									•	183	
	BQ 2507	•												•	176, 177	
	CQ 2507		•											•	179	

# Dimensional Drawings

## PANEL METERS

TYPE	Front frame □ a	Cutting for mounting □ b	Dimensions (mm) Bezel height c	Base d	Dimensions with packing (mm)	Volume with packing (dm <sup>3</sup> )	Weight with packing (kg)
BQ 0407	48	45 <sup>+0.6</sup>	5	-	55x55x75	0.23	0.10
BQ 0307	72	68 <sup>+0.8</sup>	5.5	-	80x75x75	0.45	0.16
BQ 0207	96	92 <sup>+0.8</sup>	5.5	-	102x102x75	0.78	0.20
BQ 0107	144	138 <sup>+1</sup>	8	-	155x155x80	1.92	0.43
BQ 2407	48	45 <sup>+0.6</sup>	5	-	75x60x85	0.38	0.16
BQ 2307	72	68 <sup>+0.8</sup>	5.5	-	100x90x85	0.77	0.20
BQ 2207	96	92 <sup>+0.8</sup>	5.5	-	120x110x85	1.12	0.30
BQ 2107	144	138 <sup>+1</sup>	8	-	170x160x85	2.31	0.44
CQ 0407	48	45 <sup>+0.6</sup>	5	-	55x55x75	0.23	0.10
CQ 0307	72	68 <sup>+0.8</sup>	5.5	-	80x75x75	0.45	0.16
CQ 0207	96	92 <sup>+0.8</sup>	5.5	-	102x102x75	0.78	0.22
CQ 0107	144	138 <sup>+1</sup>	8	-	155x155x80	1.92	0.44
CQ 2407	48	45 <sup>+0.6</sup>	5	-	75x60x85	0.38	0.16
CQ 2307	72	68 <sup>+0.8</sup>	5.5	-	100x90x85	0.77	0.20
CQ 2207	96	92 <sup>+0.8</sup>	5.5	-	120x110x85	1.12	0.30
CQ 2107	144	138 <sup>+1</sup>	8	-	170x160x85	2.31	0.44
CQ 3207	96	92 <sup>+0.8</sup>	5.5	-	102x102x75	0.78	0.32
FQ 0407	48	45 <sup>+0.6</sup>	5	-	55x55x75	0.23	0.10
FQ 0307	72	68 <sup>+0.8</sup>	5.5	-	80x75x75	0.45	0.16
FQ 0207	96	92 <sup>+0.8</sup>	5.5	-	102x102x75	0.78	0.24
FQ 0107	144	138 <sup>+1</sup>	8	-	155x155x80	1.92	0.40
FQ 3207	96	92 <sup>+0.8</sup>	5.5	-	102x102x75	0.78	0.32
ZQ 0317	72	68 <sup>+0.8</sup>	5.5	-	100x90x85	0.77	0.22
ZQ 0217	96	92 <sup>+0.8</sup>	5.5	-	120x110x85	1.12	0.32
ZQ 0117	144	138 <sup>+1</sup>	8	-	170x160x85	2.31	0.52
ZQ 1217	96	92 <sup>+0.8</sup>	5.5	-	120x110x85	1.12	0.43
ZQ 1117	144	138 <sup>+1</sup>	8	-	170x160x85	2.31	0.75
MQ 0407	48	45 <sup>+0.6</sup>	5	-	75x60x85	0.38	0.12
MQ 0317	72	68 <sup>+0.8</sup>	5.5	-	100x90x85	0.77	0.19/0.31*
MQ 0307	72	68 <sup>+0.8</sup>	5.5	-	100x90x85	0.77	0.15
MQ 0217	96	92 <sup>+0.8</sup>	5.5	-	120x110x85	1.12	0.27
MQ 0207	96	92 <sup>+0.8</sup>	5.5	-	120x110x85	1.12	0.22
MQ 0107	144	138 <sup>+1</sup>	8	-	170x160x85	2.31	0.50
MQ 0117	144	138 <sup>+1</sup>	8	-	170x160x85	2.31	0.55
ZQ 0407	48	45 <sup>+0.6</sup>	5	-	55x55x75	0.23	0.16
ZQ 0307	72	68 <sup>+0.8</sup>	5.5	-	80x75x75	0.45	0.20
ZQ 0207	96	92 <sup>+0.8</sup>	5.5	-	102x102x75	0.78	0.20
ZQ 0107	144	138 <sup>+1</sup>	8	-	155x155x80	1.92	0.40
ZQ 2307	72	68 <sup>+0.8</sup>	5.5	-	100x90x120	1.08	0.20
ZQ 2207	96	92 <sup>+0.8</sup>	5.5	-	160x105x102	1.71	0.20
ZQ 2107	144	138 <sup>+1</sup>	8	-	150x150x137	3.08	0.40
YQ 0307	72	68 <sup>+0.8</sup>	5.5	29	102x76x104	0.81	0.24
YQ 0207	96	92 <sup>+0.8</sup>	5.5	27.3	102x120x105	1.29	0.35

Note: \* with/without transformer

# Dimensional Drawings

## PANEL METERS

TYPE	Front frame □ a	Cutting for mounting □ b	Dimensions (mm) Bezel height c	Base d	Dimensions with packing (mm)	Volume with packing (dm <sup>3</sup> )	Weight with packing (kg)
YQ 0107	144	138 <sup>+1</sup>	8	27.3	155x155x137	3.29	0.60
YQ 2307	72	68 <sup>+0.8</sup>	5.5	29	102x76x104	0.81	0.28
YQ 2207	96	92 <sup>+0.8</sup>	5.5	27.3	102x120x105	1.29	0.45
YQ 2107	144	138 <sup>+1</sup>	8	27.3	155x155x137	3.29	0.65
EQ 0307	72	68 <sup>+0.8</sup>	5.5	29	102x76x104	0.81	0.24
EQ 0207	96	92 <sup>+0.8</sup>	5.5	27.3	102x120x105	1.29	0.35
EQ 0107	144	138 <sup>+1</sup>	8	27.3	155x155x137	3.29	0.60
EQ 2307	72	68 <sup>+0.8</sup>	5.5	29	102x76x104	0.81	0.28
EQ 2207	96	92 <sup>+0.8</sup>	5.5	27.3	102x120x105	1.29	0.45
EQ 2107	144	138 <sup>+1</sup>	8	27.3	155x155x137	3.29	0.65
WQ 0217	96	92 <sup>+0.8</sup>	5.5	54.3	160x105x102	1.71	0.90
WQ 1217	96	92 <sup>+0.8</sup>	5.5	54.3	160x105x102	1.71	0.95
WQ 1208	96	92 <sup>+0.8</sup>	5.5	54.3	160x105x102	1.71	0.90
WQ 0207	96	92 <sup>+0.8</sup>	5.5	54.3	160x105x102	1.71	0.95
WQ 2207	96	92 <sup>+0.8</sup>	5.5	54.3	160x105x102	1.71	0.95
WQ 1247	96	92 <sup>+0.8</sup>	5.5	27.3	102x115x95	1.11	0.90
KQ 0207	96	92 <sup>+0.8</sup>	5.5	-	105x105x95	1.05	0.30
MI 7350	96	92 <sup>+0.8</sup>	5.5	54.3	98x152x100	1.49	0.60
SQ 0204	96	92 <sup>+0.8</sup>	5.5	48.5	102x102x120	1.25	0.50
SQ 0104	144	138 <sup>+1</sup>	8	28	150x150x140	2.57	0.71
SQ 0114	144	138 <sup>+1</sup>	8	28	150x150x140	2.57	0.71
SQ 0214	96	92 <sup>+0.8</sup>	5.5	48.5	102x102x120	1.25	0.55
ZQ 1207	96	92 <sup>+0.8</sup>	5.5	54.3	160x105x102	1.71	0.50
ZQ 1208	96	92 <sup>+0.8</sup>	5.5	54.3	97x61x97	0.57	0.26
FQ 1207	96	92 <sup>+0.8</sup>	5.5	54.3	160x105x102	0.78	0.45
FQ 1208	96	92 <sup>+0.8</sup>	5.5	54.3	102x102x75	1.39	0.50
MC 740, MC 744, MC 750, MC 754 AC supply	96	92 <sup>+0.8</sup>	5.5	37	213x138x152	5.03	0.80
MC 740, MC 744, MC 750, MC 754 DC supply	96	92 <sup>+0.8</sup>	5.5	37	213x138x152	5.03	0.65
MC 760, MC 764 AC supply	110	87.7 <sup>+0.8</sup>	19	-	213x138x152	5.03	0.80
MC 760, MC 764 DC supply	110	87.7 <sup>+0.8</sup>	19	-	213x138x152	5.03	0.65
UMC 740 AC supply	110	87.7 <sup>+0.8</sup>	19	-	213x138x152	5.03	0.80
UMC 740 DC supply	110	87.7 <sup>+0.8</sup>	19	-	213x138x152	5.03	0.65
UMC 750 AC supply	110	87.7 <sup>+0.8</sup>	19	-	213x138x152	5.03	0.80
UMC 750 DC supply	110	87.7 <sup>+0.8</sup>	19	-	213x138x152	5.03	0.65
UMC 760 AC supply	110	87.7 <sup>+0.8</sup>	19	-	213x138x152	5.03	0.75
UMC 760 DC supply	110	87.7 <sup>+0.8</sup>	19	-	213x138x152	5.03	0.65

# Dimensional Drawings

## SCALES, MEASURING TRANSDUCERS

- weight, dimensions

Scales			
TYPE	Dimensions (mm)	Spread without cutout (mm)	Weight (g)
xQ x107	131 x 129.6	16980	19.81
xQ x207	84.7 x 86.3	7310	8.53
xQ x307	62.7 x 61.4	3850	4.49
xQ x407	39.4 x 40.1	1580	1.84
xQ x507	39.4 x 40.1	1580	1.84

Measuring transducers - weight					
TYPE	Powered from measuring circuit	Universal power supply		AC power supply	
	Weight - kg	Weight - kg	Weight of transducer with communication and 3 outputs - kg	Weight - kg	Weight of transducer with communication - kg
(U)MT 560		0.600			
(U)MT 550		0.600			
(U)MT 540		0.600			
(U)MT 518		0.420			
(U)MT 516		0.420			
(U)MT 511		0.420			
(U)MT 510		0.420			
MT 406		0.280			
MT 408		0.280			
MT 416		0.340			
MT 418		0.340			
MT 440		0.370			
MI 450		0.282		0.372	
MI 452		0.282		0.372	
MI 454		0.282		0.372	
MI 456		0.282		0.372	
MI 458		0.282		0.372	
MI 485		0.293			

# Dimensional Drawings

## MEASURING TRANSDUCERS, MEASURING CENTRES, COMMUNICATION ADAPTERS, - weight, dimensions

Measuring transducers - dimensions		
TYPE	Dimensions with packing - mm	Volume with packing - dm <sup>3</sup>
MT 560/UMT 560	135 x 90 x 170	2.065
MT 550/UMT 550	135 x 90 x 170	2.065
MT 540/UMT 540	135 x 90 x 170	2.065
MT 518/UMT 518	135 x 85 x 105	1.205
MT 516/UMT 516	135 x 85 x 105	1.205
MT 511/UMT 511	135 x 85 x 105	1.205
MT 510/UMT 510	135 x 85 x 105	1.205
MT 406	123 x 61 x 87	0.964
MT 408	123 x 61 x 87	0.964
MT 416	123 x 61 x 87	0.964
MT 418	123 x 61 x 87	0.964
MT 440	135 x 85 x 105	1.205
MI 450	123 x 61 x 87	0.653
MI 452	123 x 61 x 87	0.653
MI 454	123 x 61 x 87	0.653
MI 456	123 x 61 x 87	0.653
MI 458	123 x 61 x 87	0.653
MI 485	123 x 61 x 87	0.653

Measuring centres			
TYPE	Dimensions with packing (mm)	Volume with packing (dm <sup>3</sup> )	Weight (kg)
MC 640, MC 650, MC 660	155 x 215 x 93	3.099	0.4
MC 646, MC 656, MC 666	155 x 215 x 93	3.099	0.55

Communication adapters			
TYPE	Dimensions with packing (mm)	Volume with packing (dm <sup>3</sup> )	Weight (kg)
MI 480	123 x 87 x 111	1.19	0.53 AC/0.33 UNI*
MI 485	123 x 87 x 60	0.64	0.32 AC/0.24 UNI*
MI 486/488	123 x 87 x 60	0.64	0.36 AC/0.25 UNI*

\* AC -auxiliary power supply; UNI-universal power supply.

# Dimensional Drawings

## ENERGY METERS FOR RAIL MOUNTING

- weight, dimensions

Dimensions (on special request)					
TYPE		EQ 0107 YQ 0107	EQ 2107 YQ 2107	EQ 0207 YQ 0207	EQ 2207 YQ 2207
Bezel height (mm)	□ a	144	144	96	96
Panel cut-out (mm)	□ b	138 <sup>+1.0</sup>	138 <sup>+1.0</sup>	92 <sup>+0.8</sup>	92 <sup>+0.8</sup>
Bezel height (mm)	□ c	144	144	96	96
Protection cover (mm)	□ e	90	90	90	92
Scales length (mm)		135	135	95	95
Base (mm)	d	54	54	28	54
Weight approx.		0.9	1.1	0.5	0.7

\* Figure on page 77.



# Dimensional Drawings

## ANALOGUE METERS

### Fixing elements

with a screw

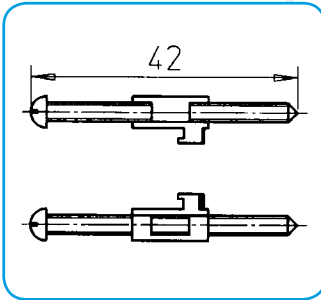

for mosaic fixing

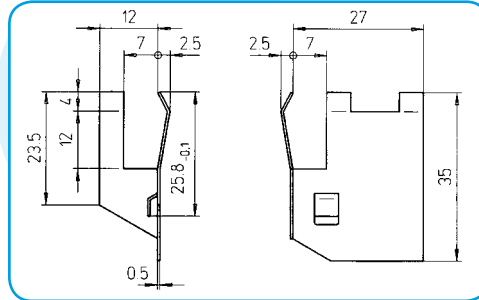

TYPE		DIMENSIONS (mm)						
		A	C	D	E	F	G	H
BN 0103	for ratings from 7.5 A to 60 A	13	11.5	64 <sup>+/-0.2</sup>	85	25 <sup>+/-0.2</sup>	25 <sup>+/-0.2</sup>	72
BN 0103		16.5	11.5	64 <sup>+/-0.2</sup>	85	25 <sup>+/-0.2</sup>	25 <sup>+/-0.2</sup>	72
BN 0203	for ratings from 7.5 A to 60 A	13	16	103 <sup>+/-0.2</sup>	105	31 <sup>+/-0.2</sup>	51 <sup>+/-0.2</sup>	96
BN 0203		16.5	16	103 <sup>+/-0.2</sup>	105	31 <sup>+/-0.2</sup>	51 <sup>+/-0.2</sup>	96
CN 0103		13	11.5	64 <sup>+/-0.2</sup>	85	25 <sup>+/-0.2</sup>	25 <sup>+/-0.2</sup>	72
CN 0203		13	16	103 <sup>+/-0.2</sup>	105	31 <sup>+/-0.2</sup>	51 <sup>+/-0.2</sup>	96
FN 0103		132 <sup>1)</sup>	11.5	103 <sup>+/-0.2</sup>	85	25 <sup>+/-0.2</sup>	25 <sup>+/-0.2</sup>	72
FN 0201		132 <sup>1)</sup>	16	103 <sup>+/-0.2</sup>	105	31 <sup>+/-0.2</sup>	51 <sup>+/-0.2</sup>	96

<sup>1)</sup> for ranges FN = 15...60 A and BN = 7.5...60 A : M6

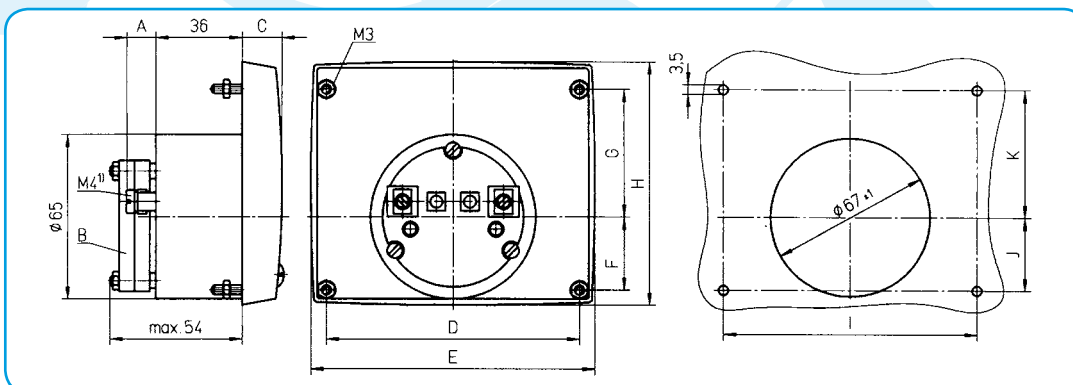

<sup>1)</sup> for ranges FN = 15...60 A and BN = 7.5...60 A: 16.5 mm

# Dimensional Drawings

## MEASURING TRANSFORMER

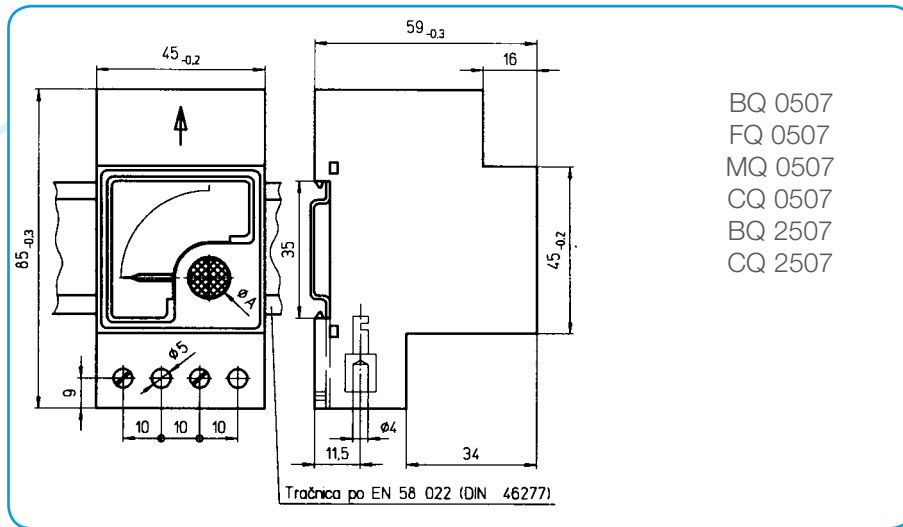

Measuring transformer for add-on 1 or 5 A for CQ 0407 and CQ 2407

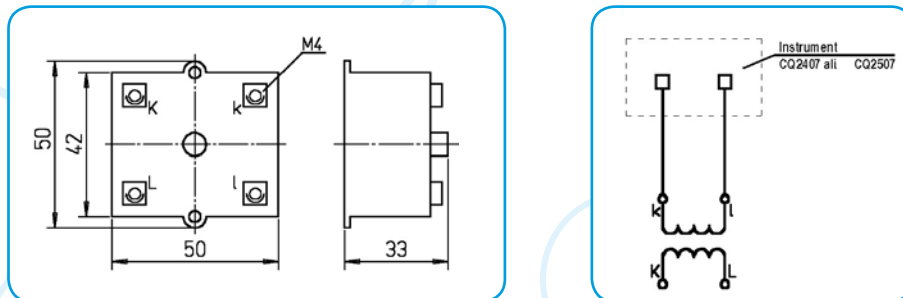

Protection of front side IP65

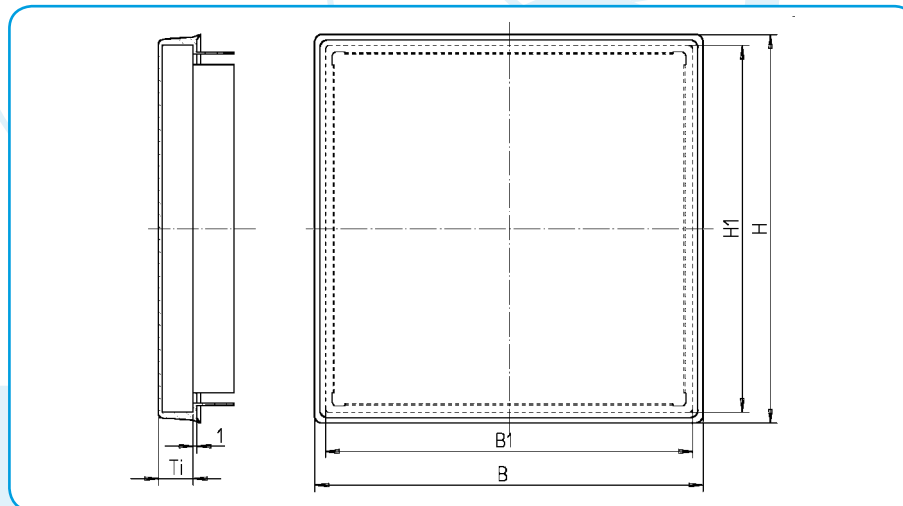

B	H	Ti	B1	H1	Size
54	54	8	48.4	48.4	Q 48
78	78	8	72.4	72.4	Q 72
102	102	8	96.4	96.4	Q 96
150	150	9	144.4	144.4	Q 144

# Dimensional Drawings

## SYNCHROSCOPE

### MiBOX

SYNCHROSCOPE

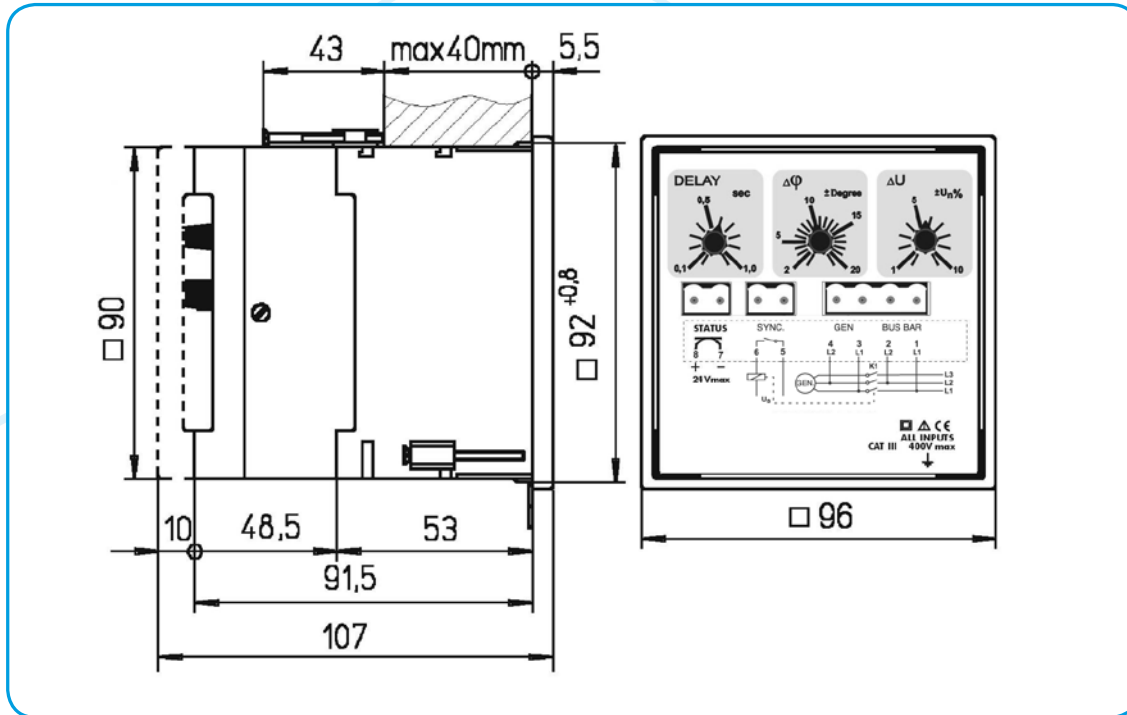

MiBOX

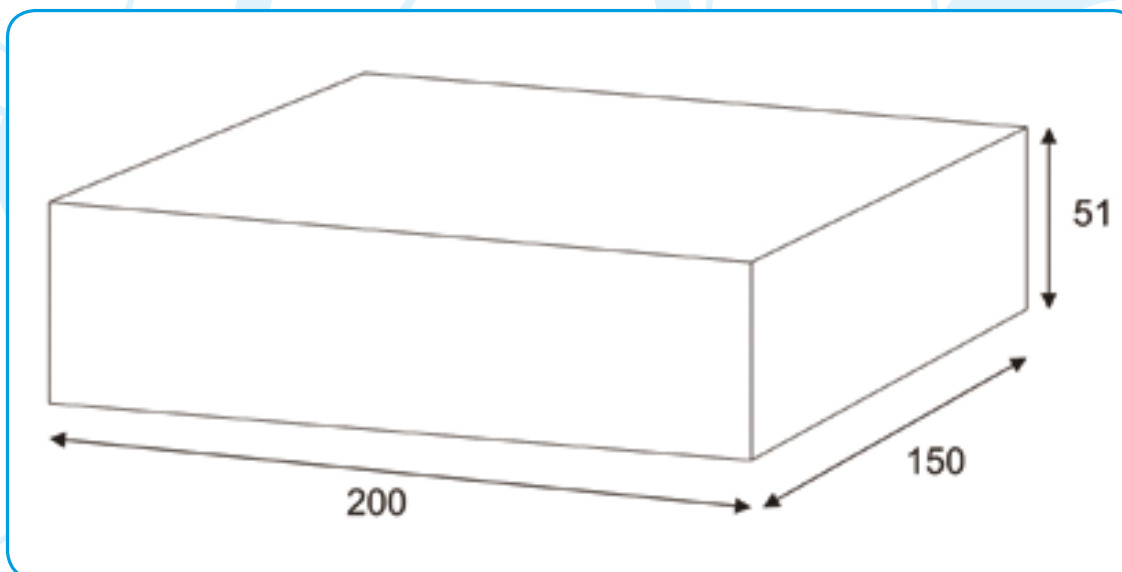

# Dimensional Drawings

## MEASURING TRANSDUCERS

MT 5x0/UMT5x0

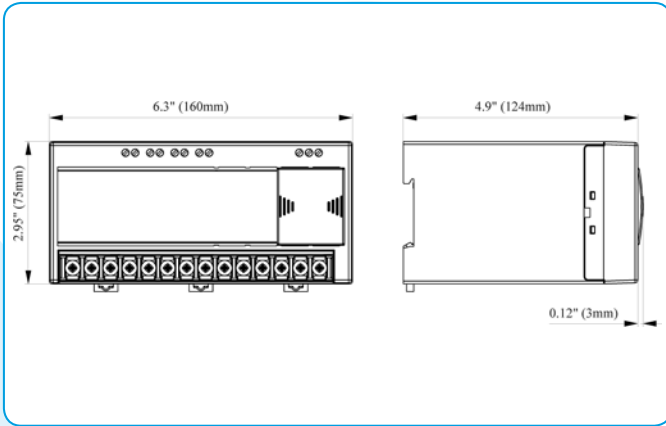

MT 51x/UMT 51x

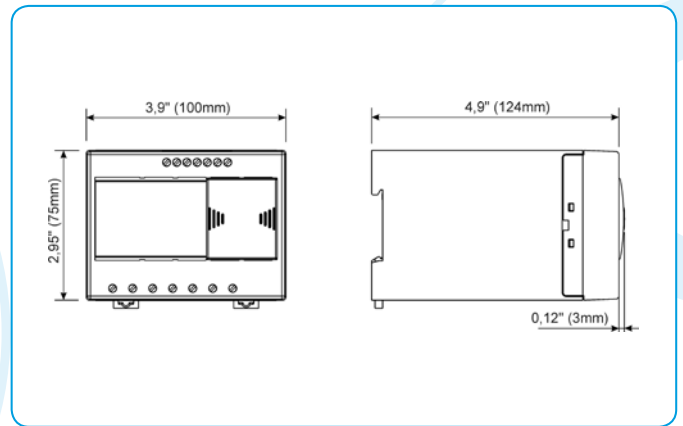

MI 4xx

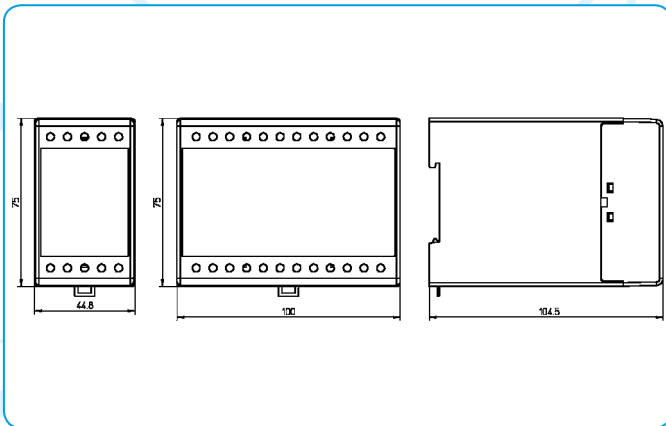

RD 500

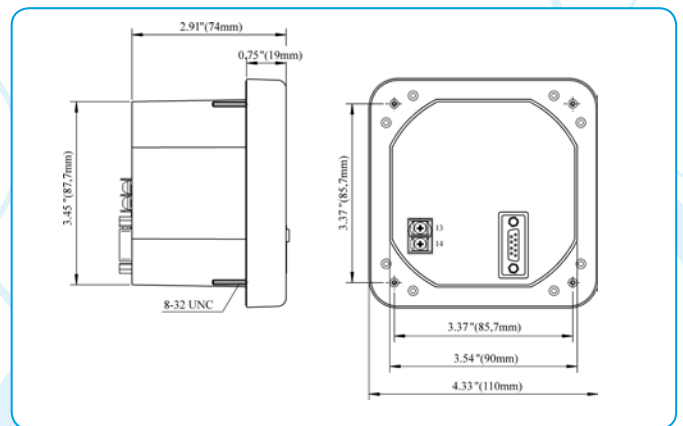

MT 406, MT 408, MT 416, MT 418

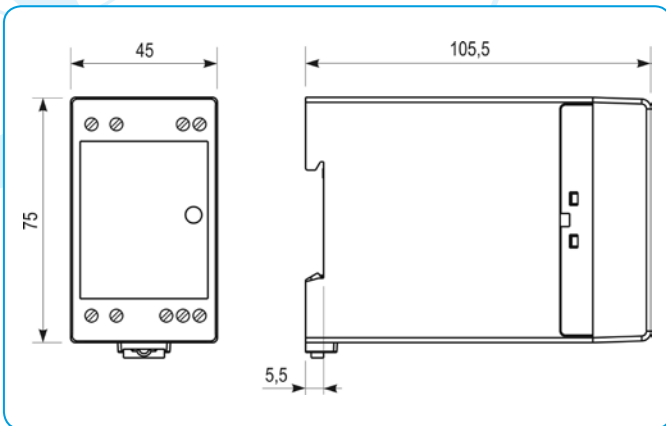

MT 440

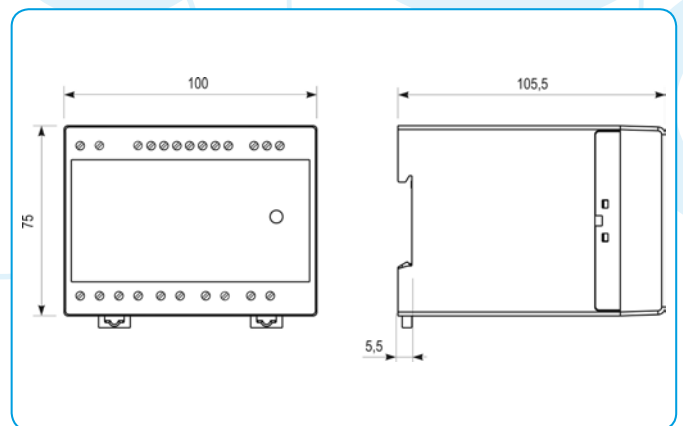

# Dimensional Drawings

## MEASURING CENTRES

UMC 760, UMC 750, UMC 740

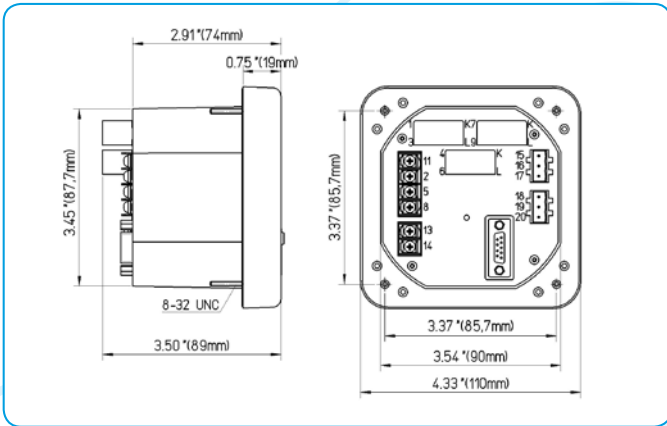

MC 760, MC 750, MC 740

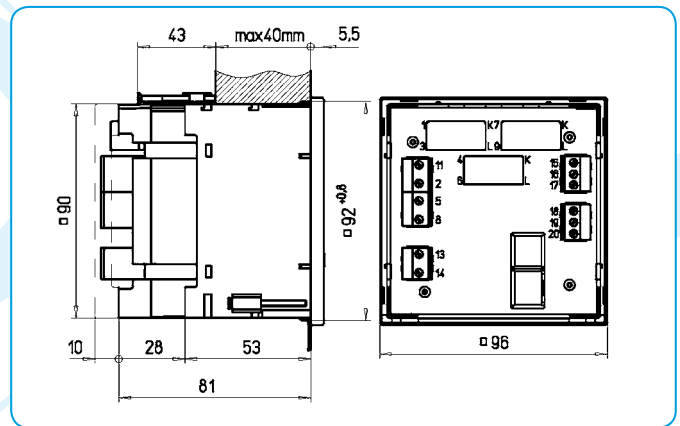

MC 764, MC 754, MC 744

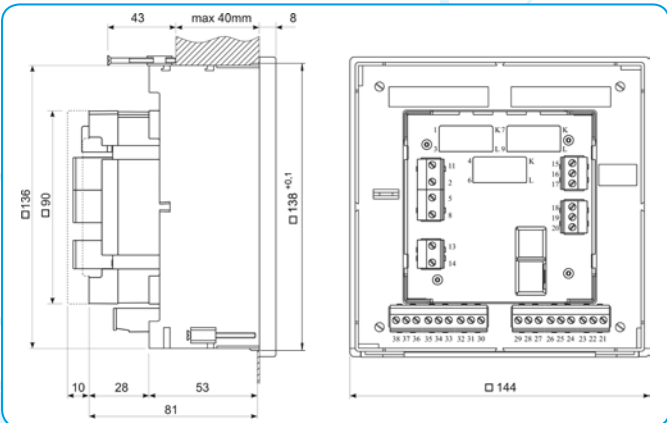

MC 6x0, MC 6x6

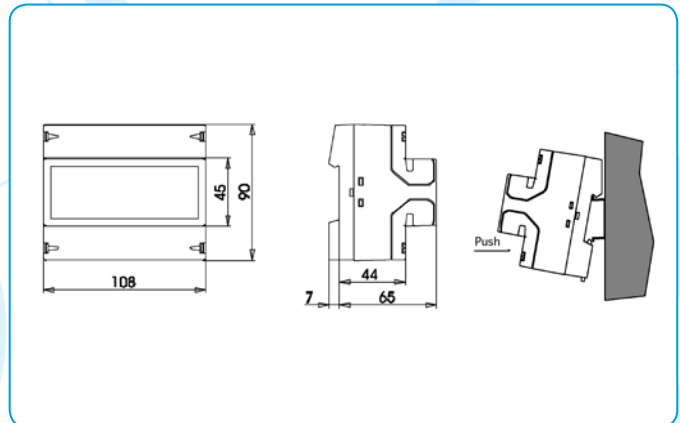

MC 330, MC 320

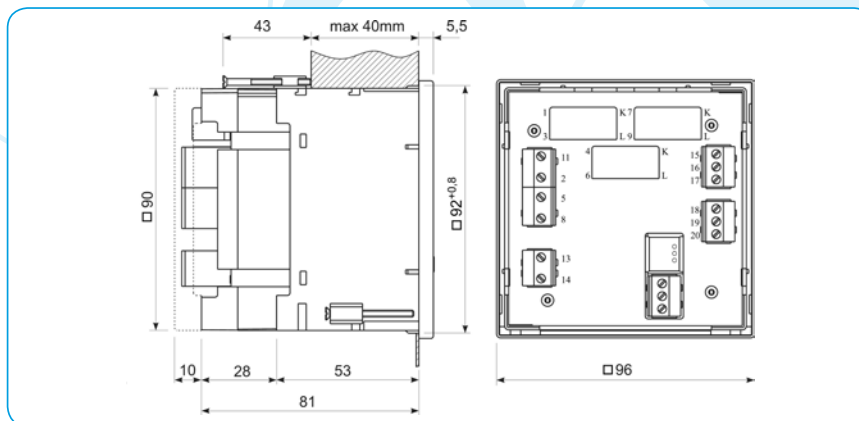

# Dimensional Drawings

## DIGITAL METERS

DM 302, DM 306, DM 308, DM 310

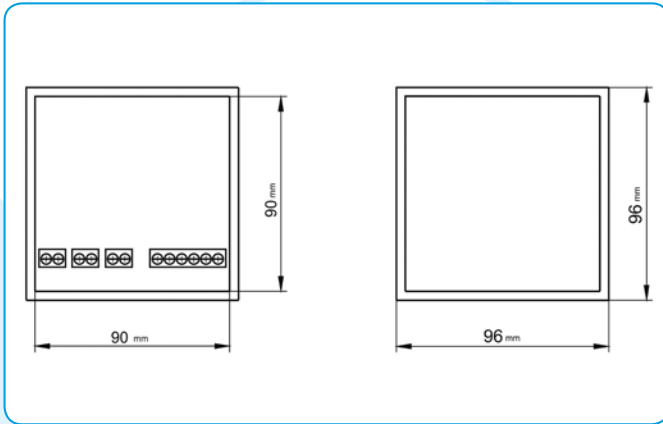

DM 202, DM 206, DM 208

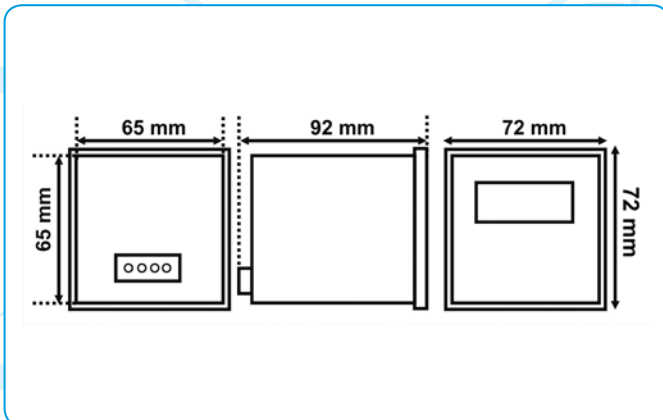

DM 210

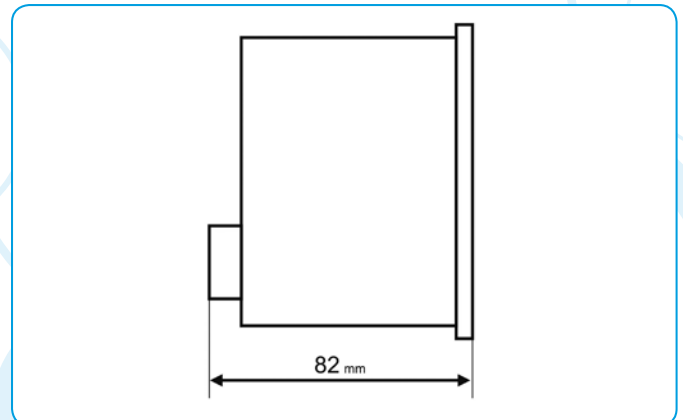

# Dimensional Drawings

## CURRENT MEASURING TRANSFORMERS

TYPE	FRONT	BOTTOM	FROM SIDE
1. ASR 20.3 2. ASR 201.3			
1. ASR 21.3 2. ASR 22.3, ASR 22.3 2U			
1. ASK 205.3 2. ASK 21.3			
1. ASK 231.5 2. ASK 31.3, ASK 31.3 2U			
1. ASK 318.3 2. ASK 31.4, ASK 31.4 2U, ASK 31.4 3U			
1. ASK 31.5, ASK 31.5 2U 2. ASK 41.3			
1. ASK 421.4 2. ASK 41.4, ASK 41.4 2U, ASK 41.4 3U			
1. ASK 412.4 2. ASK 541.4			
1. ASK 51.4, ASK 51.4 2U, ASK 51.4 3U 2. ASK 561.4			
1. ASK 61.4, ASK 61.4 2U, ASK 61.4 3U 2. ASK 63.4			

# Dimensional Drawings

## CURRENT MEASURING TRANSFORMERS

TYPE	FRONT		BOTTOM		FROM SIDE	
1. ASK 63.6 2. ASK 81.4, ASK 81.4 2U						
1. ASK 101.4, ASK 101.4 2U 2. ASK 103.3						
1. ASK 123.3 2. ASK 129.10						
1. WSK 30 2. WSK 40						
1. WSK 60 2. WSK 70.6						

**Current measuring transformers - dimensions, weight**

TYPE	Width	Height	Depth (with pedestal)	Primary cable	Diameter	Weight range	
ASR 20.3	44	65	30 (62)	-	21	0.152	0.191
ASR 201.3	44	64.5	30	-	21	0.150	0.190
ASR 21.3	48,5	65	30 (62)	-	22,5	0.230	0.280
ASR 22.3	60	78.5	30 (62)	-	22,5	0.250	0.280
ASK 205.3	48,5	65	30 (62)	20 x 5	17,5	0.200	0.198
ASK 21.3	60	78.5	30 (62)	20 x 10	19,2	0.315	0.268
ASK 231.5	49,5	70	50 (82)	30 x 10	28	0.340	0.320
ASK 31.3	60	78.5	30 (62)	30 x 10.2 x 20 x 10	26	0.267	0.240
ASK 318.3	60	78.5	30 (62)	31 x 18	26	0.238	0.250
ASK 31.4	60	78.5	40 (72)	30 x 10.2 x 20 10	28	0.375	0.300
ASK 31.5	60	78.5	50 (82)	30 x 10.2 x 20 10	28	0.450	0.350
ASK 41.3	60	78.5	30 (62)	40 x 13.32 x 18	28	0.220	0.240
ASK 421.4	70	88.5	40 (72)	20 x 10	26	0.712	0.420
ASK 41.4	70	88.5	40 (72)	40 x 10.2 x 30 x 5	20	0.462	0.345
ASK 412.4	70	88.5	40 (72)	40 x 10.2 x 30 x 15	32	0.475	0.420
ASK 541.4	85	101.5	40 (72)	40 x 10.2 x 30 x 5	30,5	0.910	0.450
ASK 51.4	85	101.5	40 (72)	50 x 12.2 x 40 x 10	32	0.536	0.460
ASK 561.4	85	101.5	40 (72)	60 x 10.2 x 50 x 10	44	0.472	0.490
ASK 61.4	95	108.5	40 (72)	63 x 10.2 x 50 x 10	44	0.520	0.490
ASK 63.4	95	108.5	40 (72)	60 x 30.5 x 40	44	0.420	0.430
ASK 63.6	88	132	60 (92)	60 x 30	44	0.740	0.835
ASK 81.4	120	126.5	40 (72)	80 x 10.6 x 30.2 x 6 x 10	30	1.000	0.565
ASK 101.4	130	144	40 (72)	100 x 10.2 x 80 x 10	55	0.550	0.713
ASK 103.3	172	187.5	31 (62)	2 x 100 x 10.3 x 80 x 10	70	0.800	0.750
ASK 123.3	172	187.5	31 (62)	123 x 30.3 x 100 x 10	85	0.800	0.850
ASK 129.1	250	250	100 (132)	120 x 90	100	3.000	3.400
WSK 30	60	78.5	30 (62) mm	-	-	0.290	0.270
WSK 40	70	88.5	40 (72) mm	-	-	0.320	0.412
WSK 60	70	88.5	60 (92) mm	-	-	0.410	0.460
WSK 70.6	70	85	60 (76) mm	-	-	0.520	0.580

# Dimensional Drawings

## SHUNTS

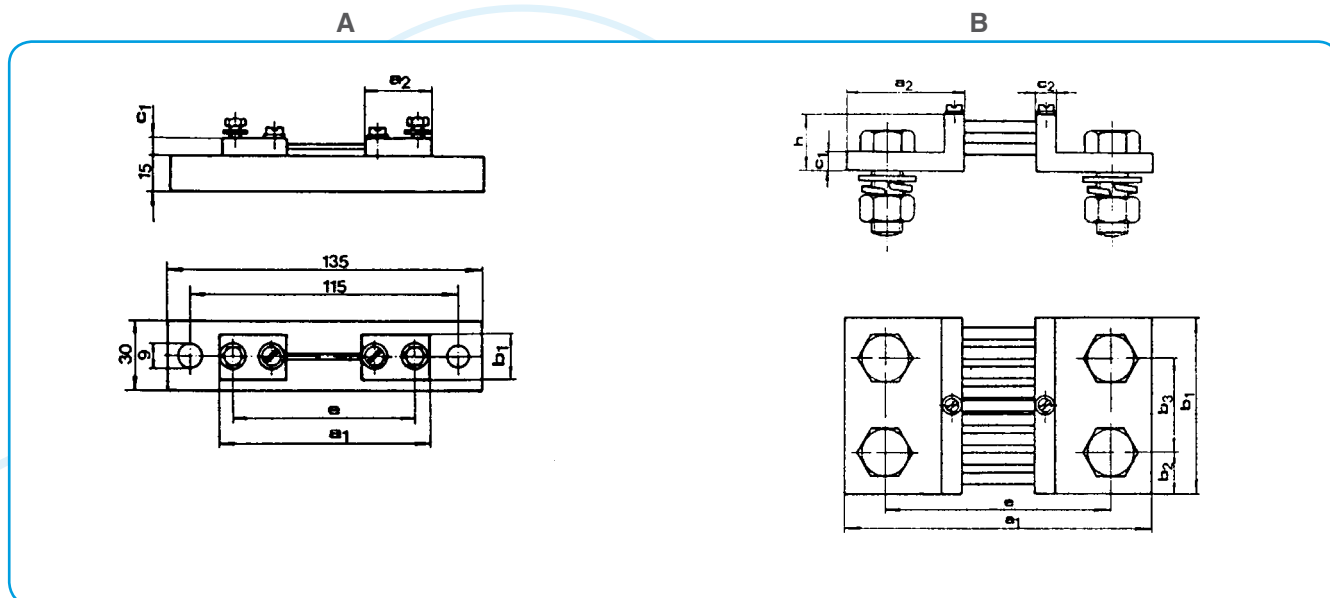

Dimensions (mm)	Current through separate shunt (A)							
	1, 1.5, 2.5, 4	40 60	250	400	600	1000	1500	2500
	6 10 15 25	100 150						
	Possibility A		Possibility B					
a1	90	100	145			165		
a2	28	33	55			65		
b1	20	20	30	40	40	60	90	120
b2	-	-	15	20	20	30	21	30
b3	-	-	-			-	48	60
c1	8	8	10					
c2	-	-	10					
e	78	80	105			115		
h1	-		30					
No. of terminals	2 x 1				2 x 2			
Fixing screw	M5 x 12	M8 x 15	M12 x 40	M16 x 45	M16 x 45	M20 x 50	M16 x 45	M20 x 50
Washer DIN 125	5.3	8.4	13.5	17	17	21	17	21
Spring washer DIN 127	-		12	16	16	20	16	20
Nut	-		M12	M16	M16	M20	M16	M20
Voltage terminals	2 cylindrical screws M5 x 8 (DIN 84-4) and 2 washers 5.3							

# Connection Diagrams

## MULTIMETER MC 330, ENERGY METER MC 320

### CONNECTION

Voltage inputs can be connected either directly to low-voltage network or via a high-voltage transformer to high-voltage network. Current inputs shall be connected to network via a corresponding current transformer.

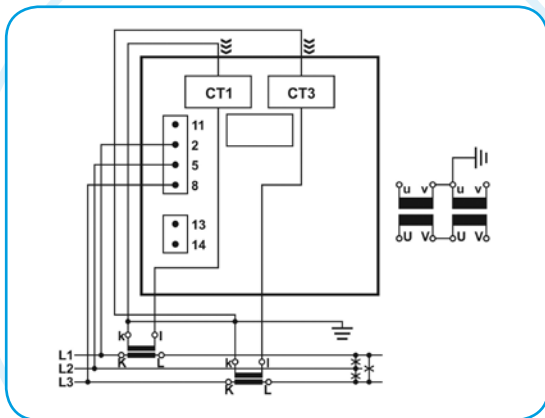

3u – three-wire, unbalanced load

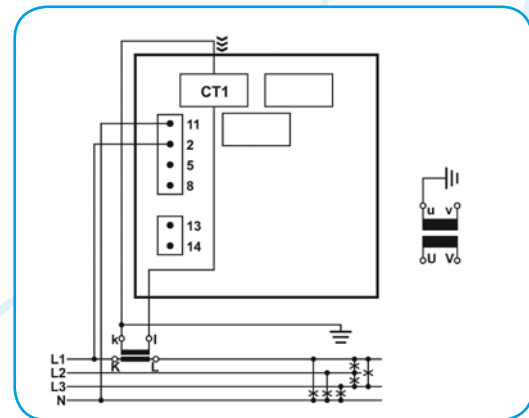

4b – four-wire, balanced load

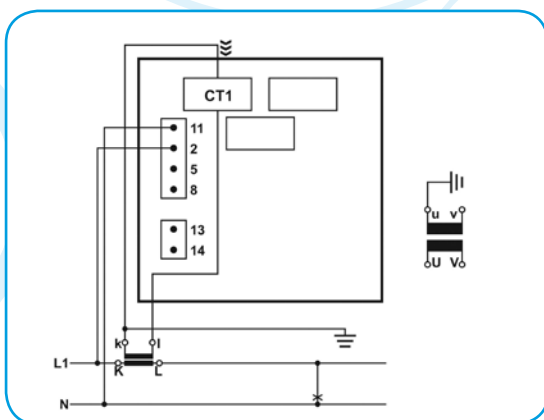

1b – single-wire, balanced load

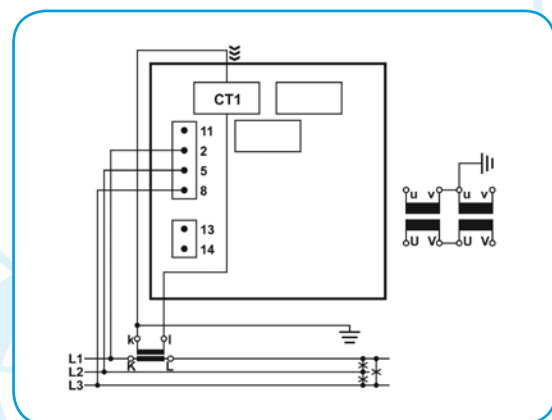

3b – three-wire, balanced load

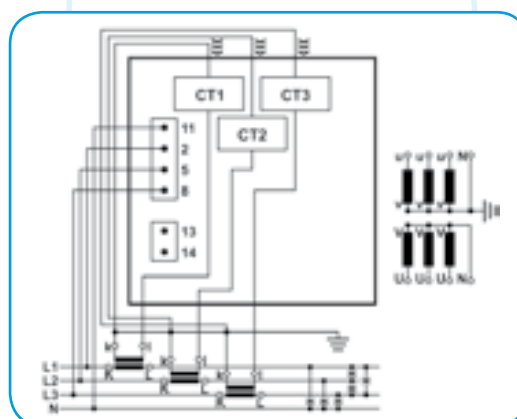

4u – four-wire, unbalanced load

# Connection Diagrams

## MEASURING CENTRES MC 7x0/UMC 7x0 - Ethernet

Converter voltage inputs can be connected directly to low-voltage network or they can be connected via a high-voltage transformer to high-voltage network. Current inputs shall be connected to network via a corresponding current transformer.

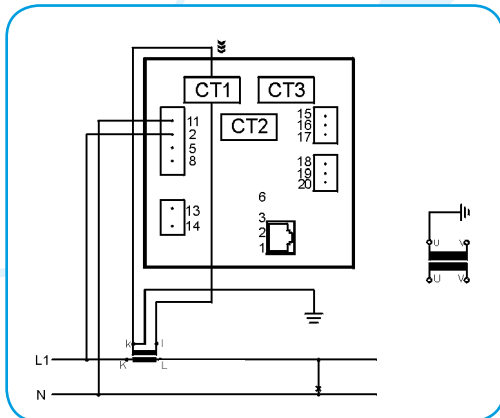

**1b - single phase, balanced load**

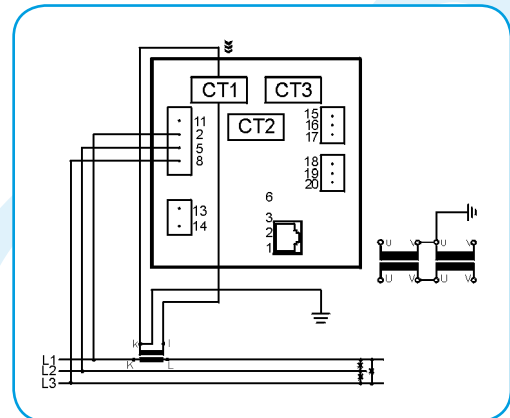

**3b - three-phase, three wires, balanced load**

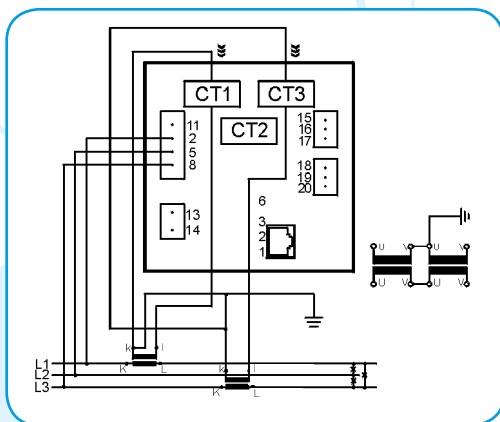

**3u - three-phase, three wires, unbalanced load**

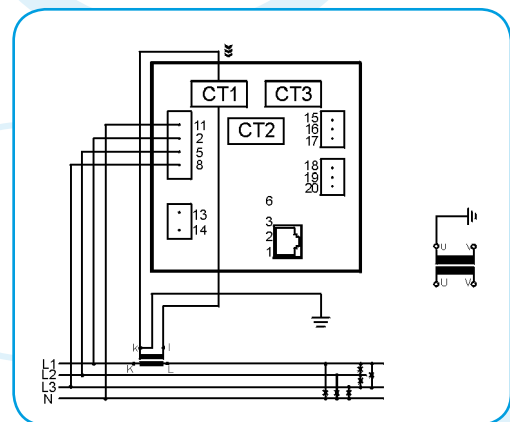

**4b - three-phase, four wires, balanced load**

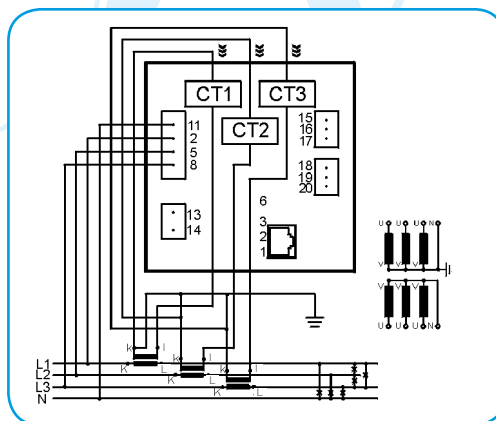

**4u - three-phase, four wires, unbalanced load**

# Connection Diagrams

## MEASURING CENTRES MC 7x0/UMC 7x0 - RS232/485

Converter voltage inputs can be connected directly to low-voltage network or they can be connected via a high-voltage transformer. Current inputs shall be connected to network via a corresponding current transformer.

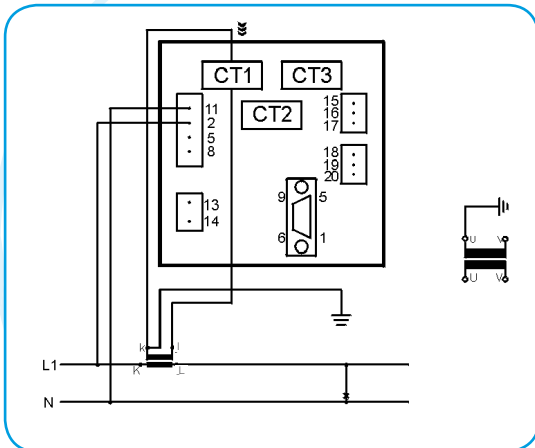

1b - single phase, balanced load

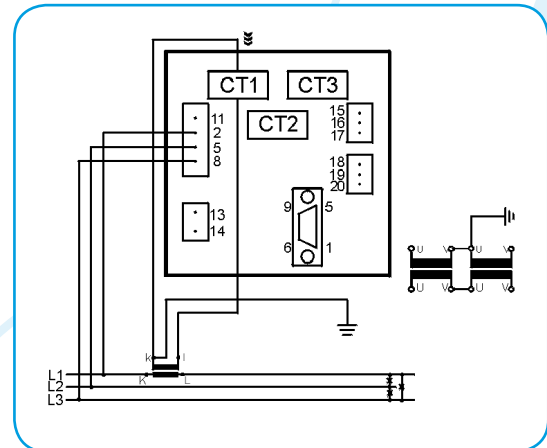

3b - three-phase, three wires, balanced load

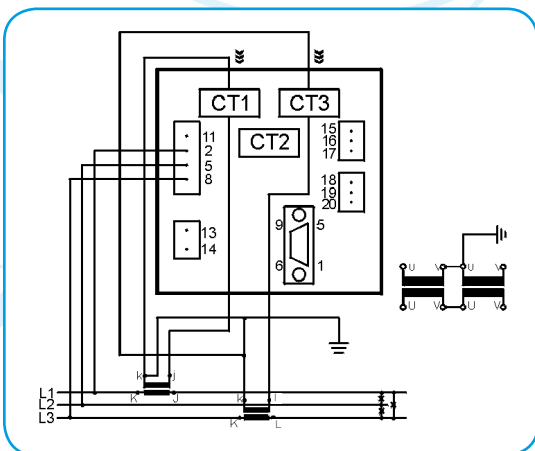

3u - three-phase, three wires, unbalanced load

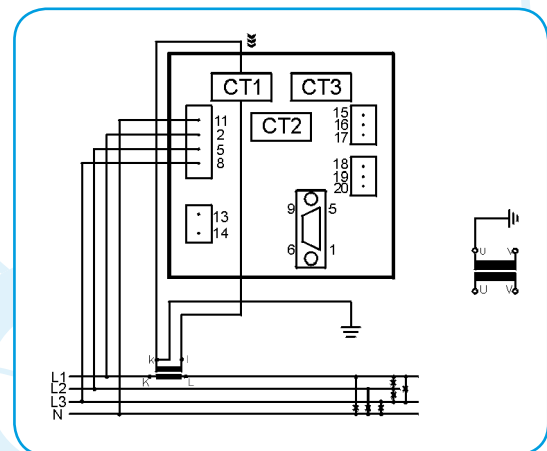

4b - three-phase, four wires, balanced load

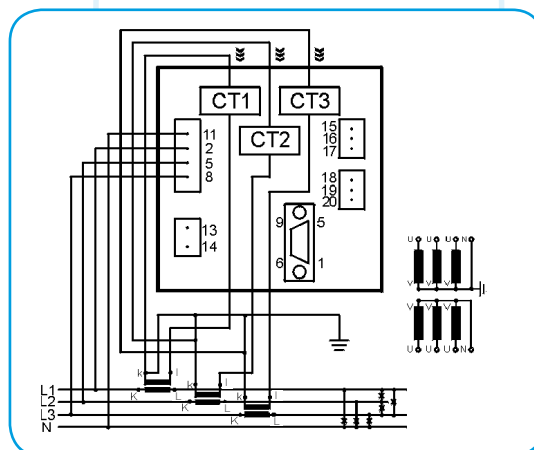

4u - three-phase, four wires, unbalanced load

# Connection Diagrams

## MEASURING CENTRES MC 7x4

Voltage inputs can be connected either directly to low-voltage network or they can be connected via a high-voltage transformer. Current inputs shall be connected to network via a corresponding current transformer.

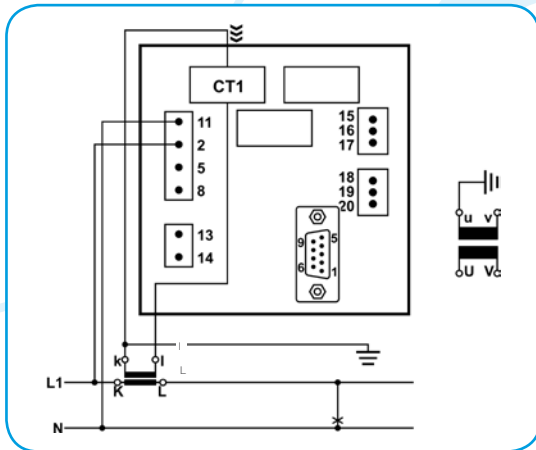

1b - single wire, balanced load

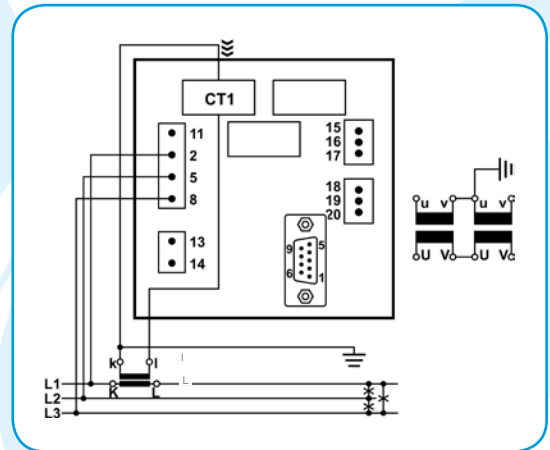

3b - Three-phase, three wires, balanced load

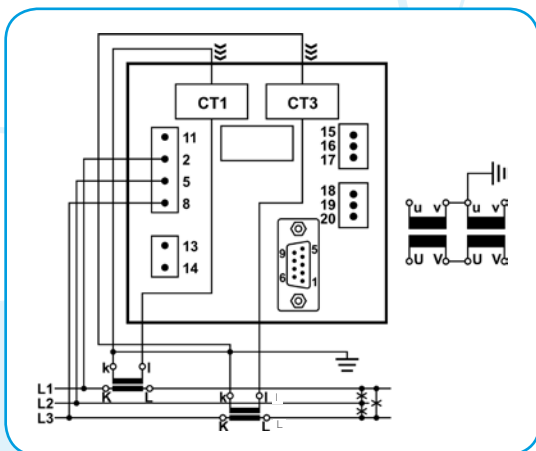

3u - three-phase, three wires, unbalanced load

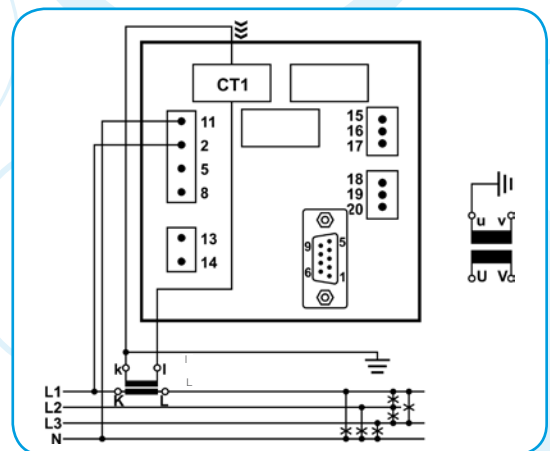

4b - three-phase, four wires, balanced load

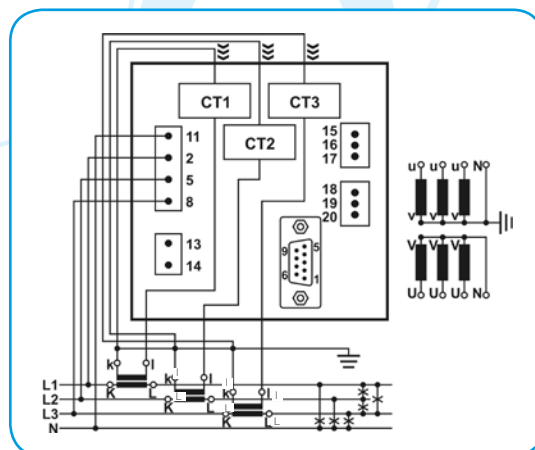

4u - three-phase, four wires, unbalanced load

# Connection Diagrams

## MEASURING CENTRES MC 6x6 (DIRECT CONNECTION)

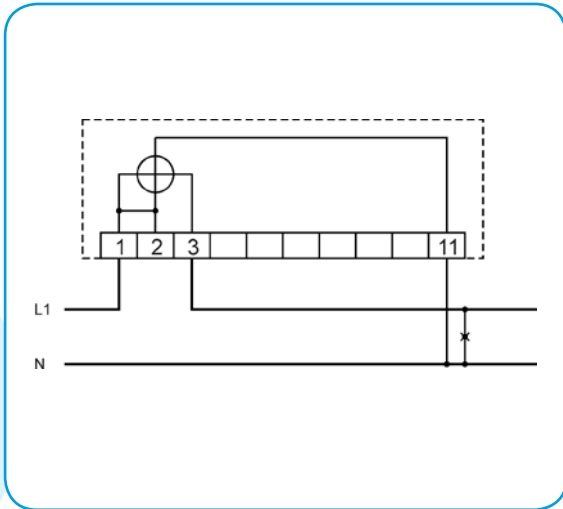

1b – single phase, balanced load

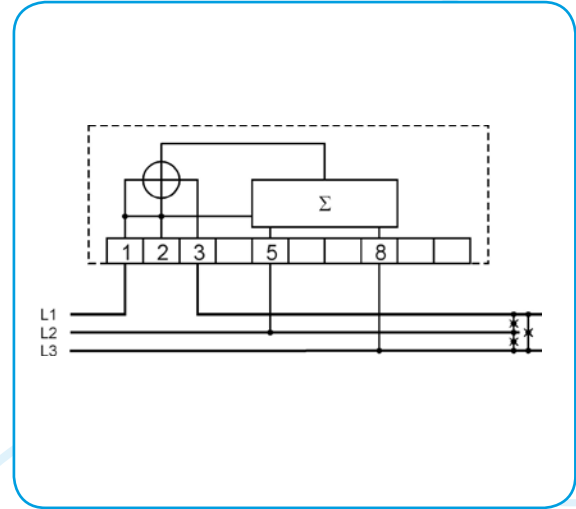

3b – three-phase, three wires, balanced load

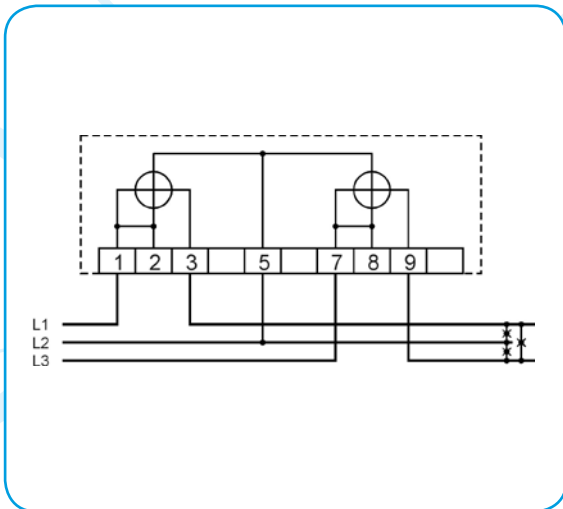

3u – three-phase, three wires, balanced load

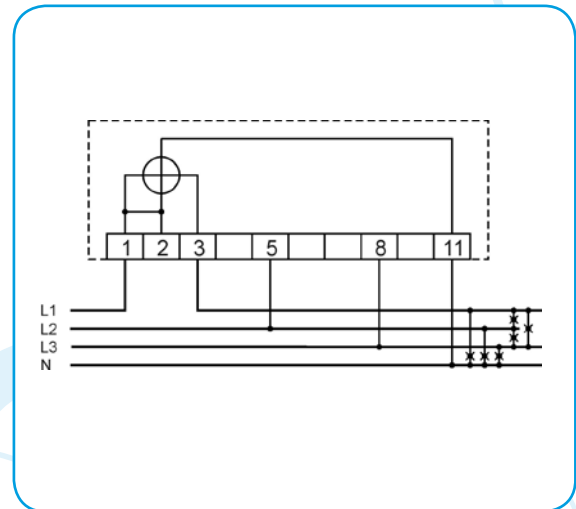

4b – three-phase, four wires, balanced load

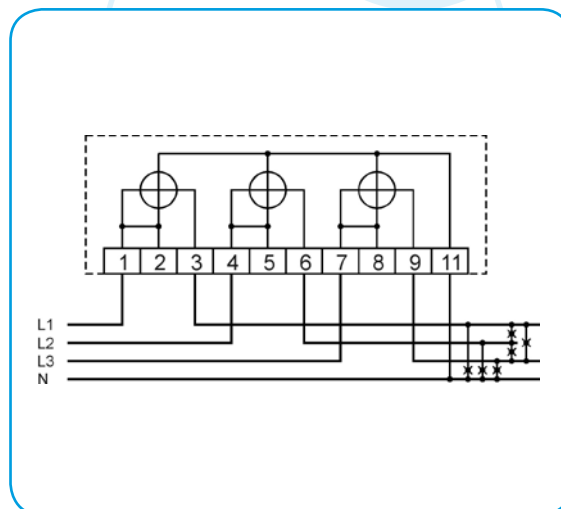

4u – three-phase, four wires, unbalanced load

# Connection Diagrams

## MEASURING CENTRES MC 6x0

### (CONNECTION VIA CURRENT TRANSFORMER)

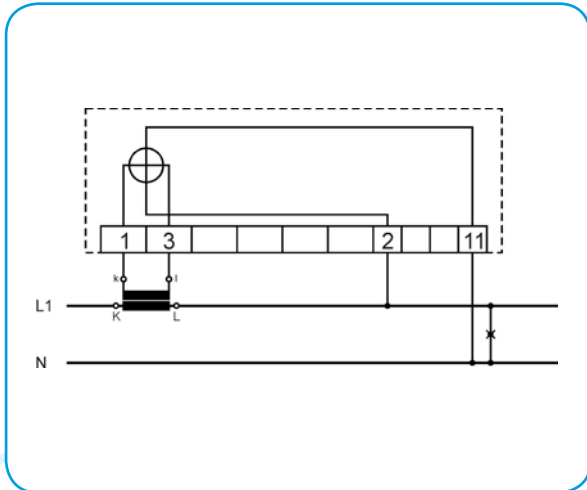

1b – single phase, balanced load

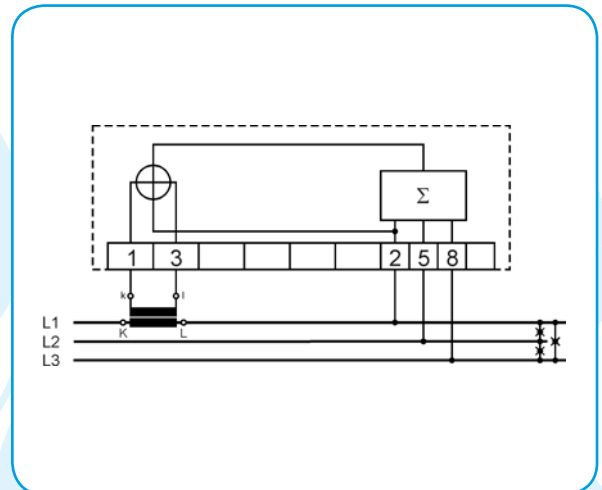

3b – three-phase, three wires, balanced load

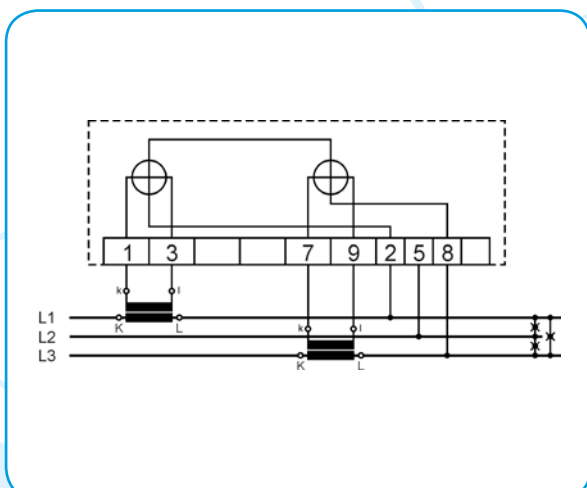

3u – three-phase, three wires, balanced load

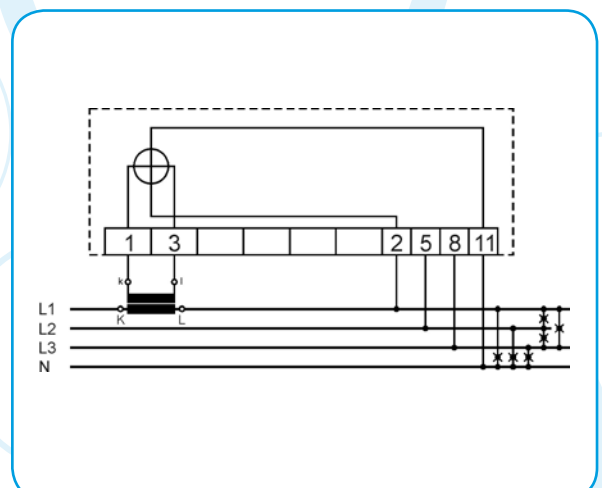

4b – three-phase, four wires, balanced load

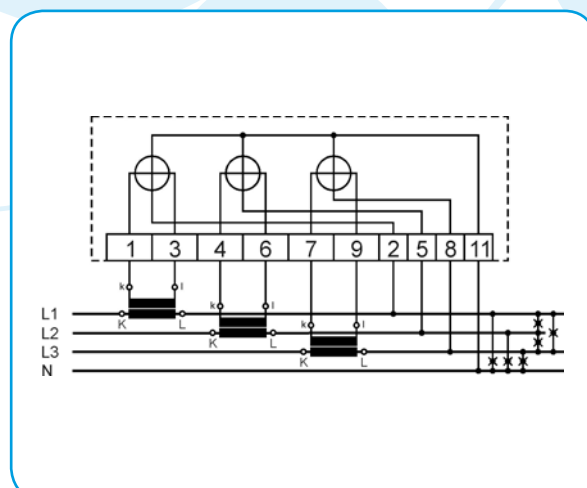

4u – three-phase, four wires, unbalanced load

# Connection Diagrams

## PANEL METERS

	1b	3b	3u	4b	4u
YQ xx07	*	*	*	*	*
EQ xx07	*	*	*	*	*
WQ xx07	*	*	*	*	*

**b** – balanced load  
**u** – unbalanced load

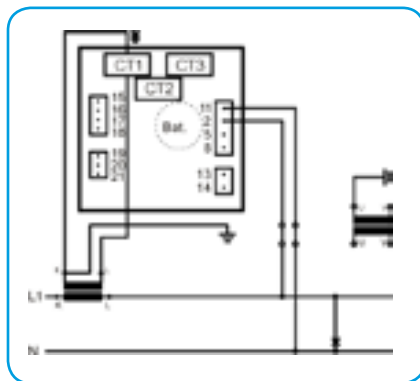

1b

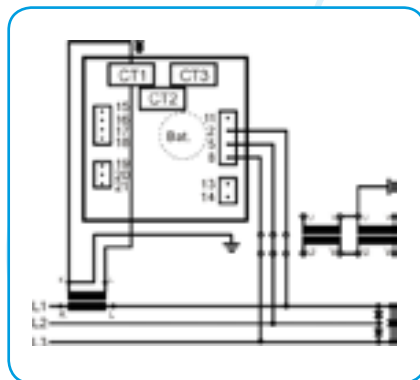

3b

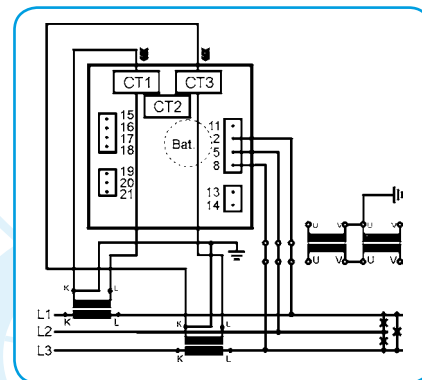

3u

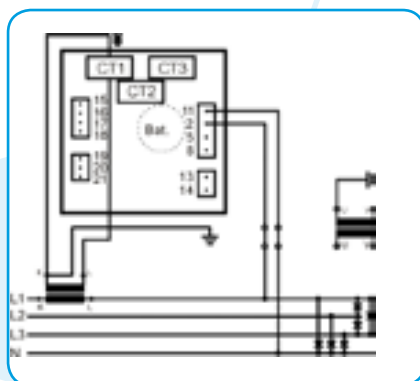

4b

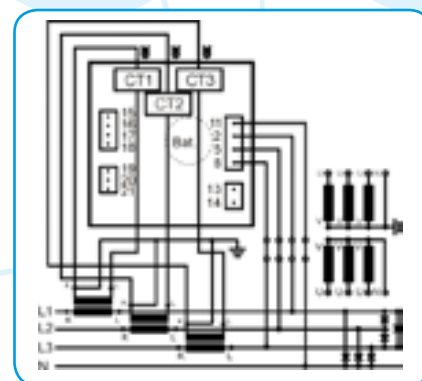

4u

Note: Connection terminals 19, 20, 21 are missing at EQ YQ, WQ types.  
 Connection terminals 13, 14 are available only for instruments with external power supply.

# Connection Diagrams

## MEASURING TRANSDUCERS MT 5x0/UMT 5x0

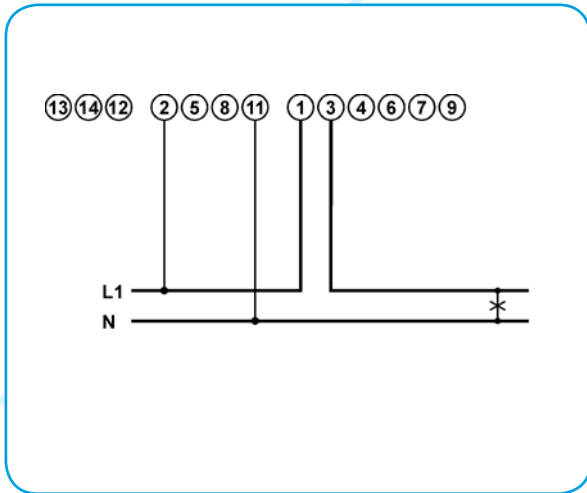

1b – single phase

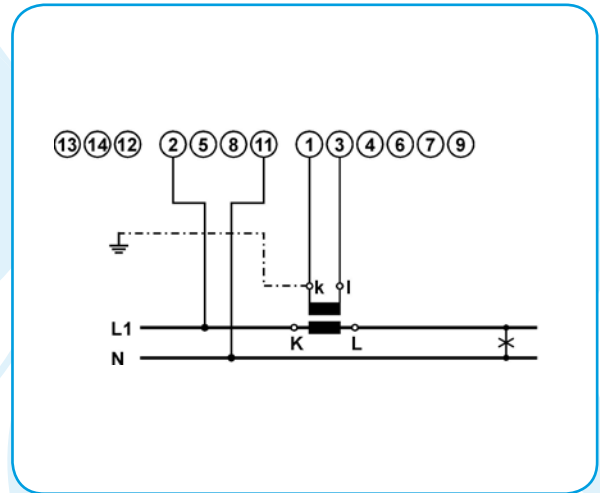

1b – single phase

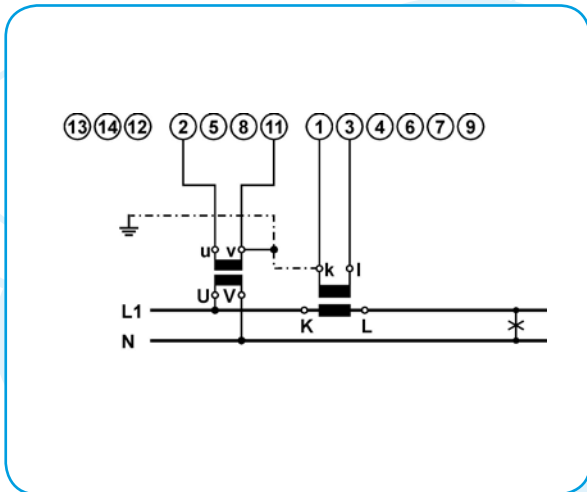

1b – single phase

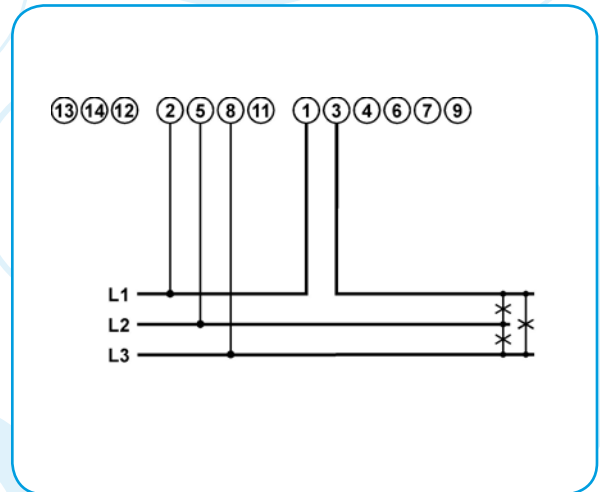

3b – three-phase, three wires, balanced load

# Connection Diagrams

## MEASURING TRANSDUCERS MT 5x0/UMT 5x0

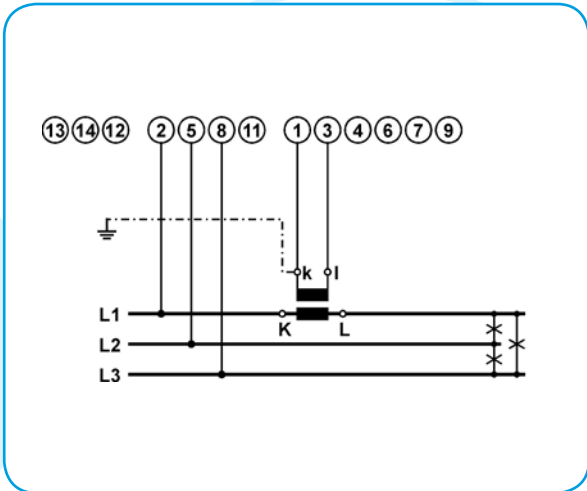

3b – three-phase, three wires, balanced load

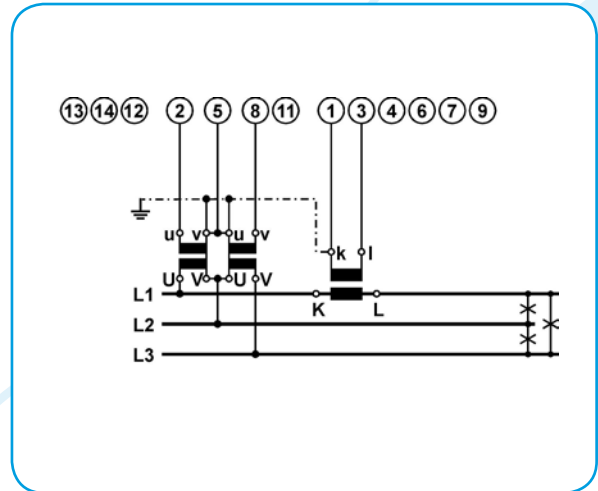

3b – three-phase, three wires, balanced load

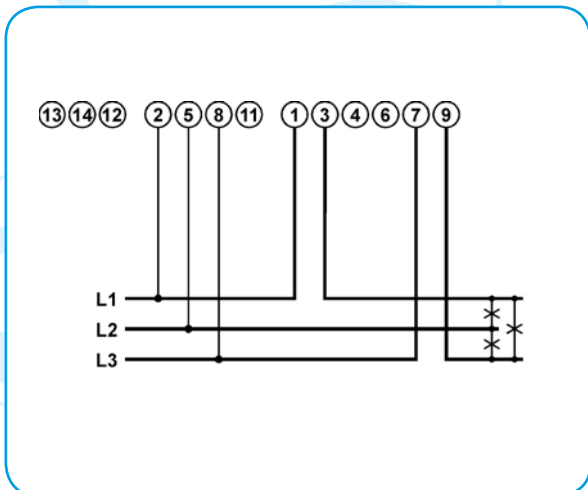

3u – three-phase, three wires, unbalanced load

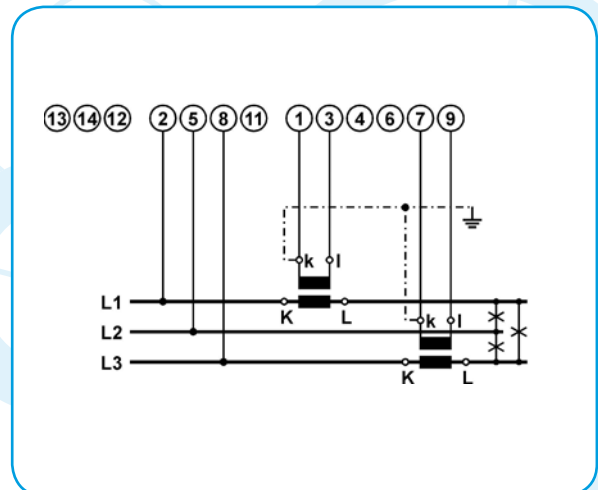

3u – three-phase, three wires, unbalanced load

# Connection Diagrams

## MEASURING TRANSDUCERS MT 5x0/UMT 5x0

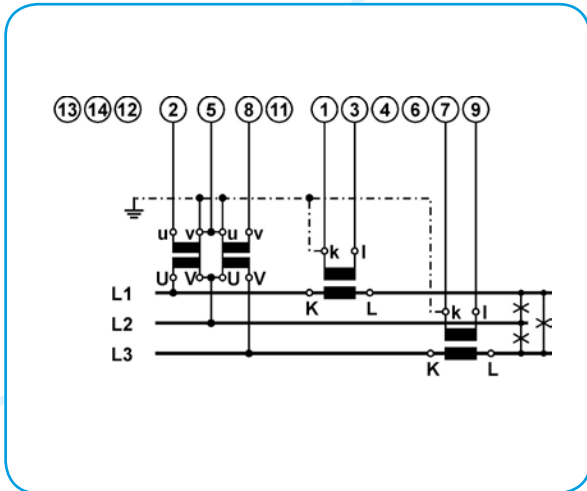

3u – three-phase, three wires, unbalanced load

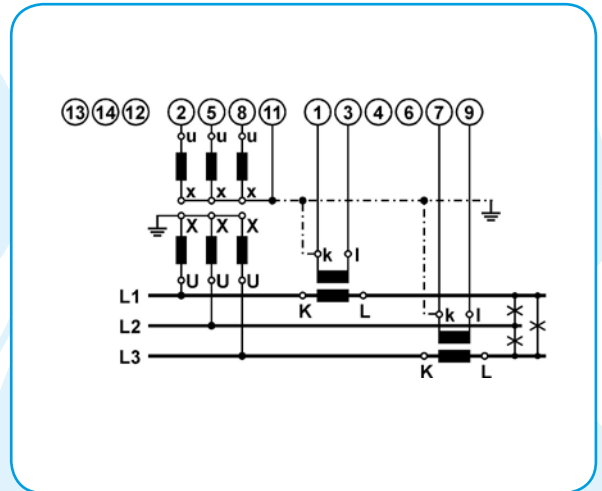

3u – three-phase, three wires, unbalanced load

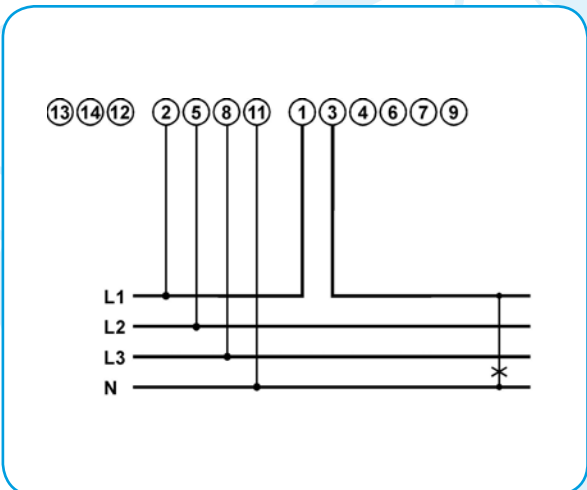

4b – three-phase, four wires, balanced load

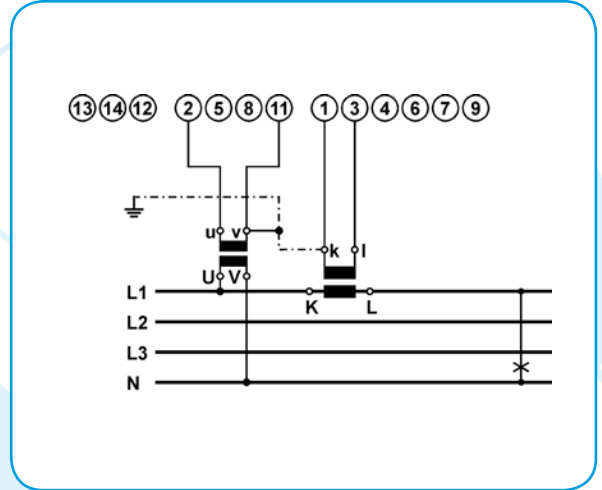

4b – three-phase, four wires, balanced load

# Connection Diagrams

## MEASURING TRANSDUCTORS MT 5x0/UMT 5x0

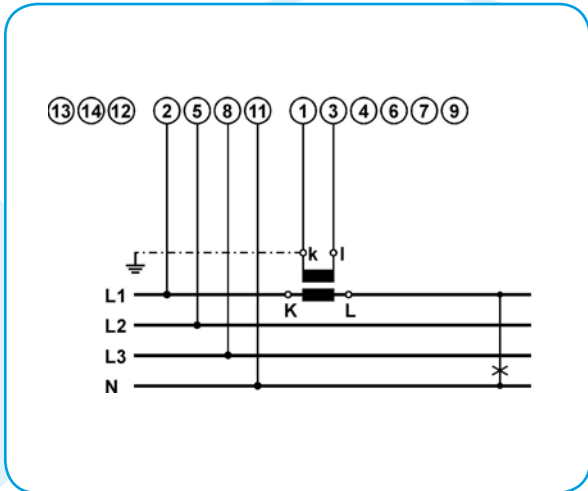

4b – three-phase, four wires, balanced load

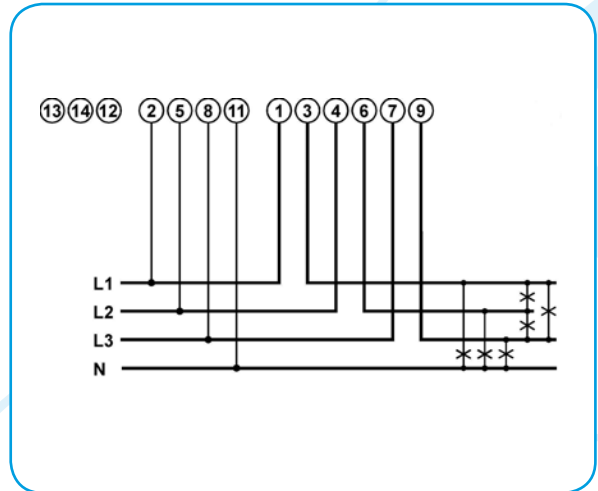

4u – three-phase, four wires, unbalanced load

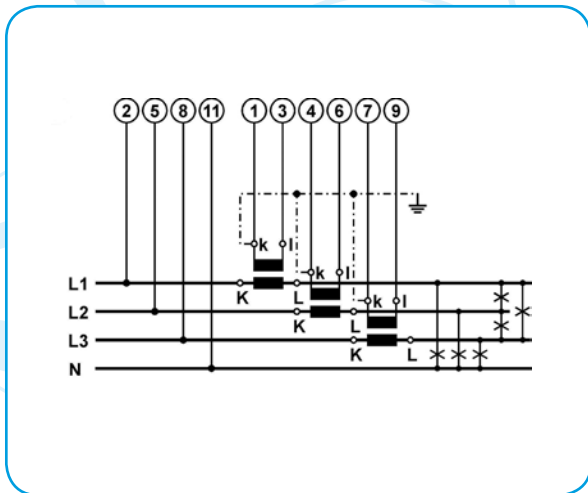

4u – three-phase, four wires, unbalanced load

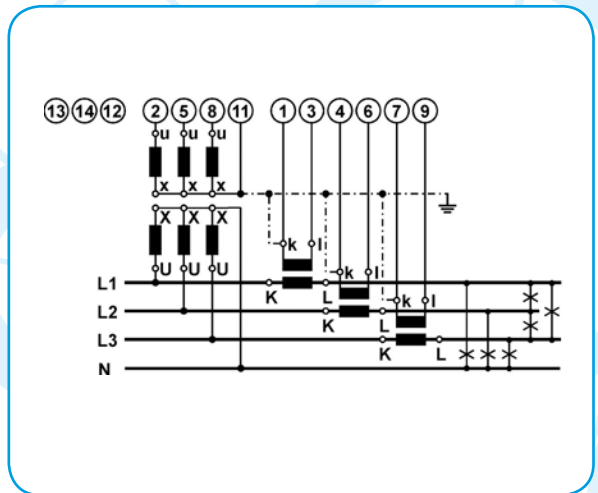

4u – three-phase, four wires, unbalanced load

# Connection Diagrams

## MEASURING TRANSDUCCERS MT 51x/UMT 51x

(U)MT 510, (U)MT 511

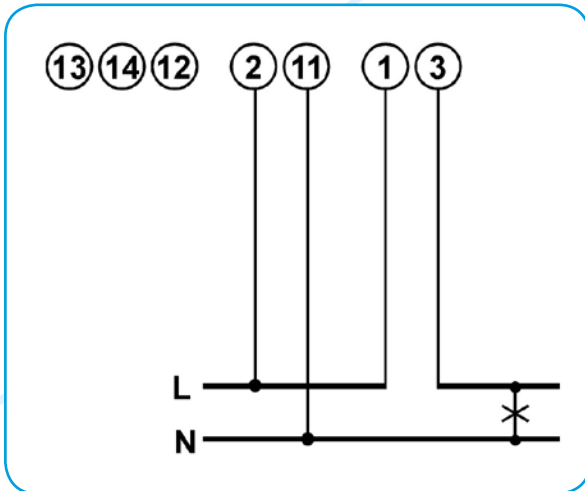

1b – single phase

(U)MT 510, (U)MT 511

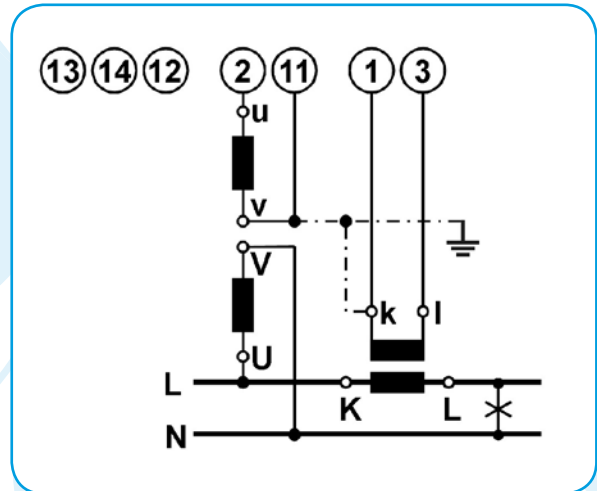

1b – single phase

(U)MT 516

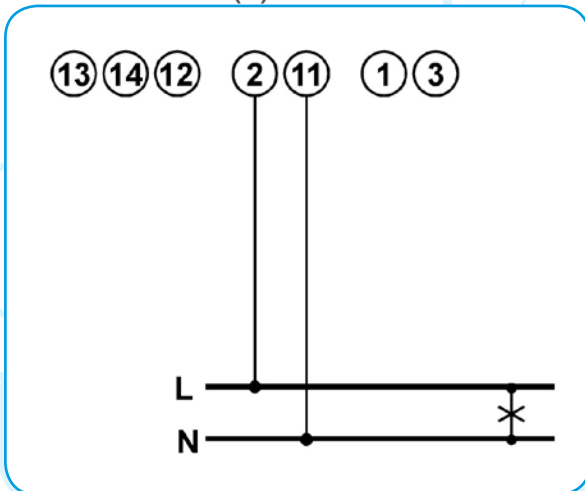

1b – single phase

(U)MT 518

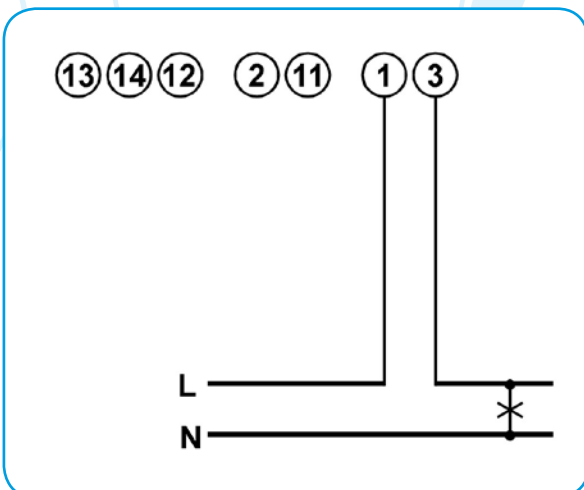

1b – single phase

(U)MT 516

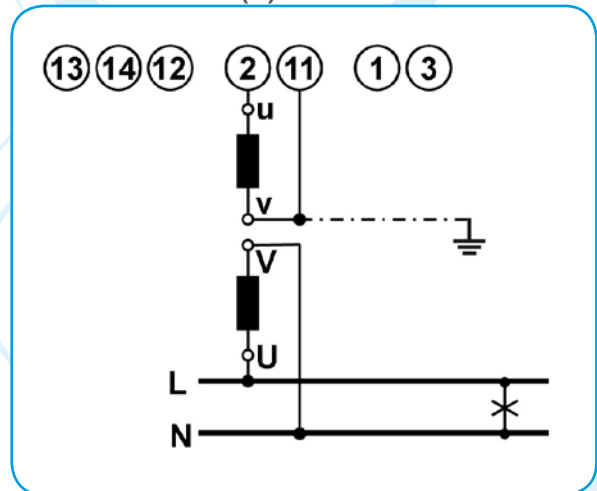

1b – single phase

(U)MT 518

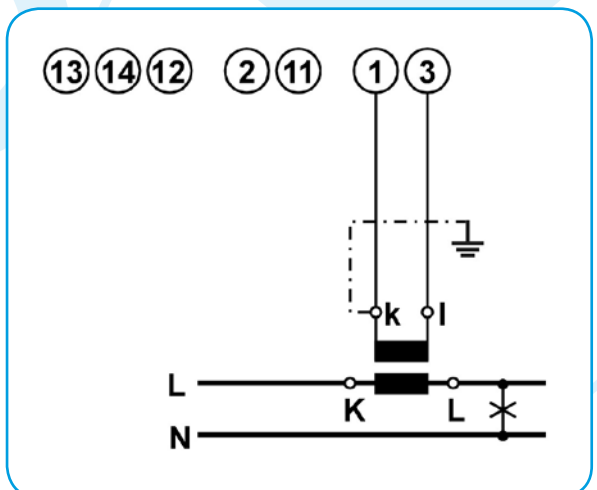

1b – single phase

# Connection Diagrams

## MEASURING TRANSDUCER MT 4xx

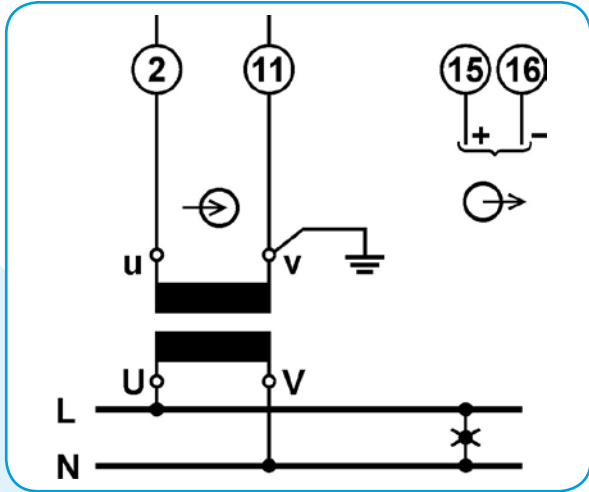

MT 406

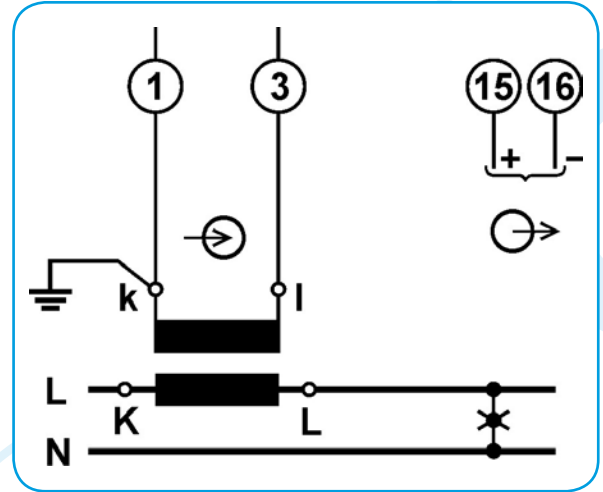

MT 408

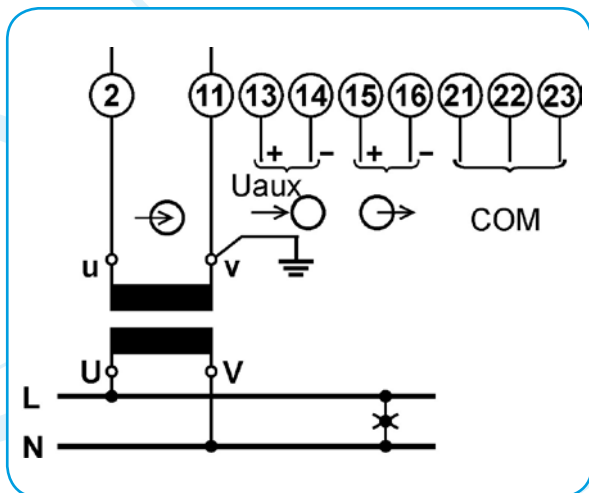

MT 416

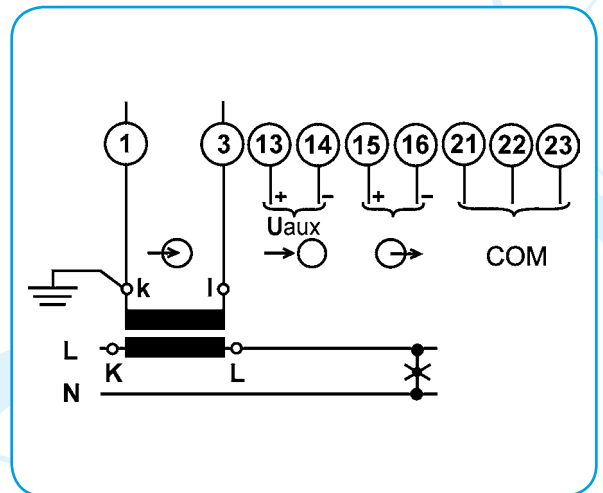

MT 418

# Connection Diagrams

## MEASURING TRANSDUCER MT 440

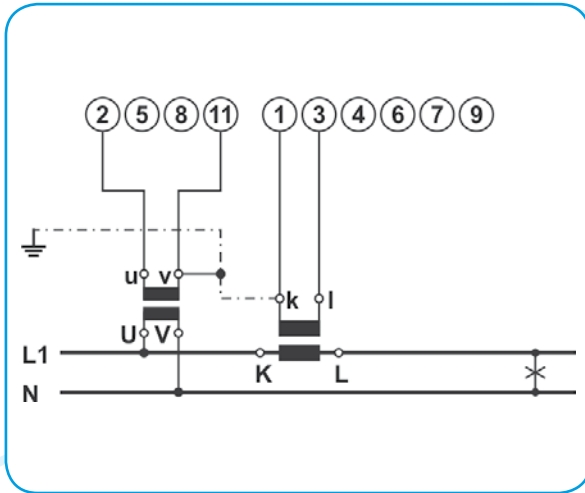

MT 440 - 1b

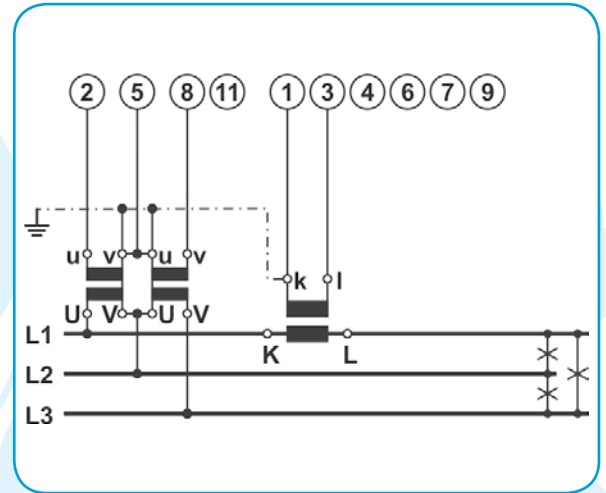

MT 440 - 3b

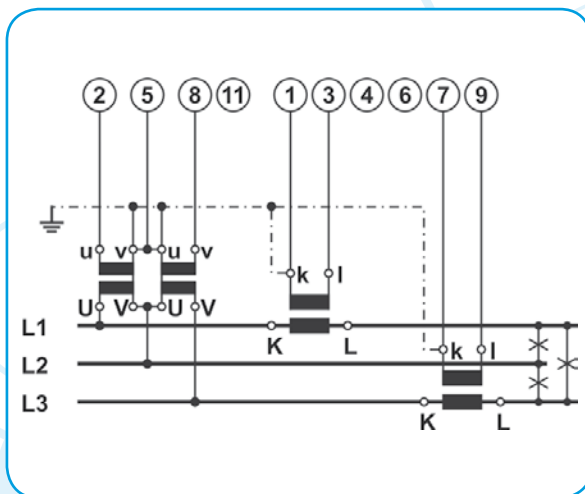

MT 440 - 3u

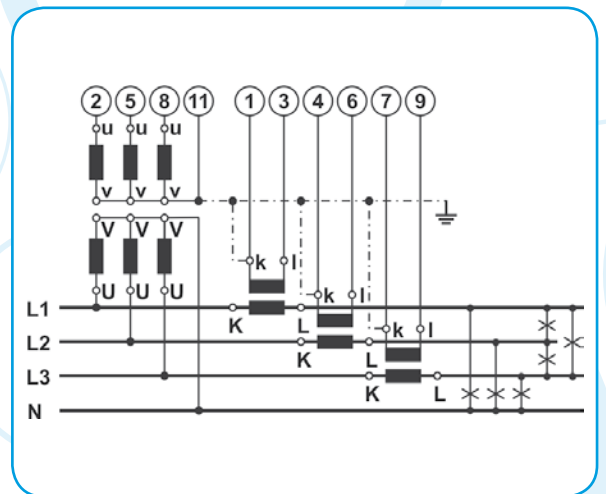

MT 440 - 4u

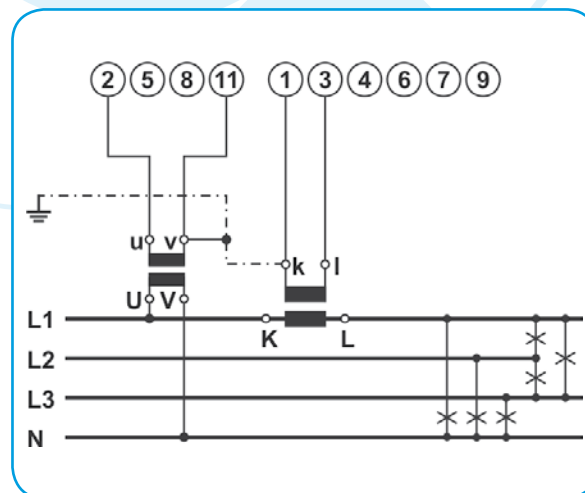

MT 440 - 4b

# Connection Diagrams

## MEASURING TRANSDUCERS MT 4xx COMMUNICATION ADAPTERS MI 48x

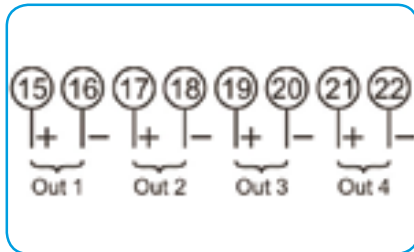

Transducers can have up to four analogue outputs

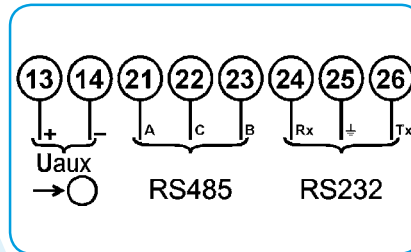

MI 485

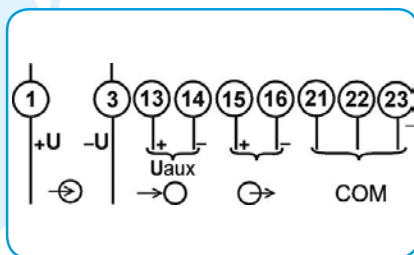

MI 456

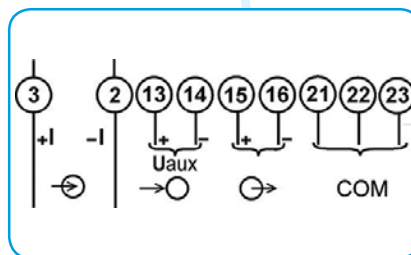

MI 458

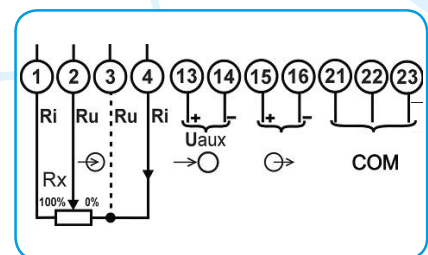

MI 454

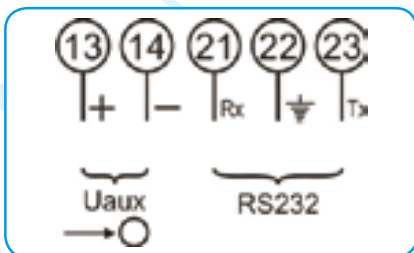

MI 486

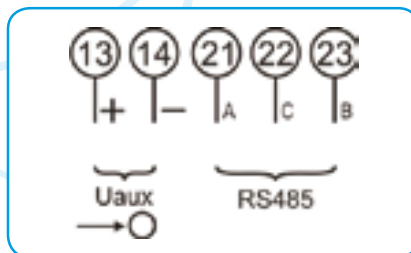

MI 488

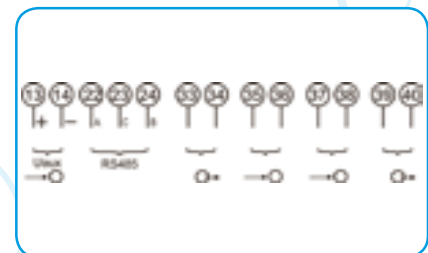

MI 480

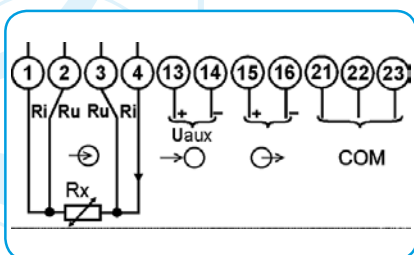

MI 452, 4-wire

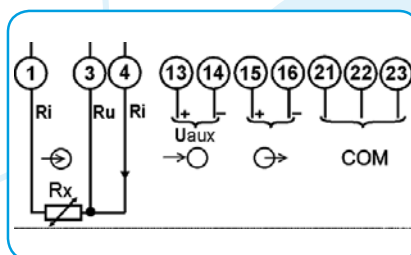

MI 452, 3-wire

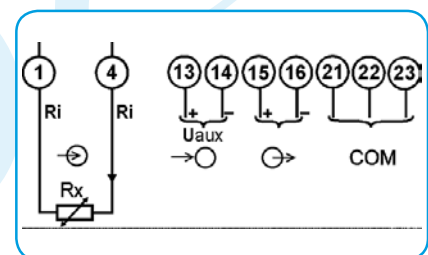

MI 452, 2-wire

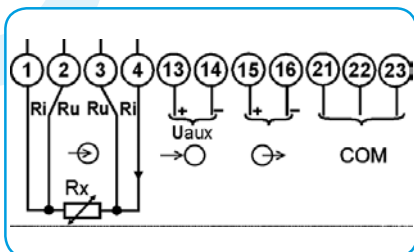

MI 450, 4-wire

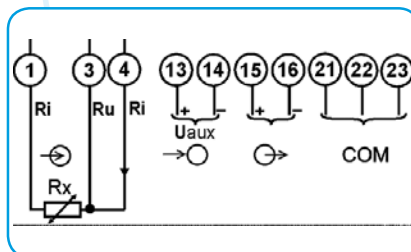

MI 450, 3-wire

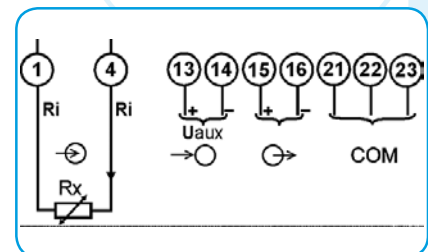

MI 450, 2-wire

Note:

Auxiliary supply on connection terminals 13 (-) and 14 (+), output on connection terminals 15 (-) and 16 (+).

# Connection Diagrams

## TAP POSITION METERS

### CONNECTION DIAGRAMS FOR TAP POSITION METERS

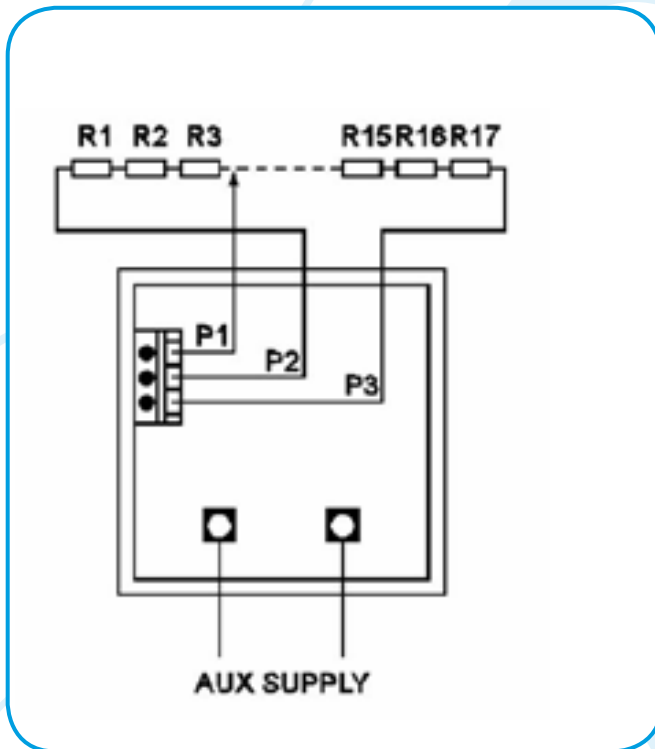

CQ 2207

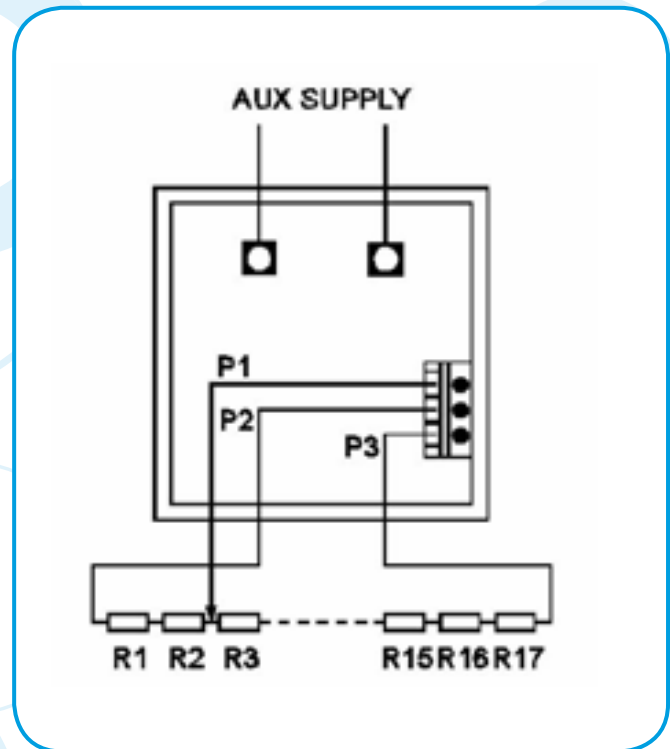

CQ 0207

# Connection Diagrams

ANALOG METERS ZQ 120x, FQ 120x, CQ 3207, FQ 3x07,  
SQ 02x4, SQ 01x4, FQ 1108, ZQ 1108

Connection diagram for: SQ 02x4, SQ 01x4

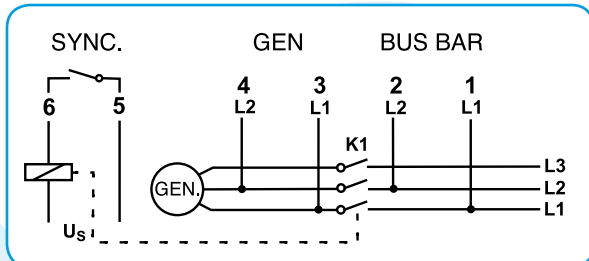

Phase to phase connection

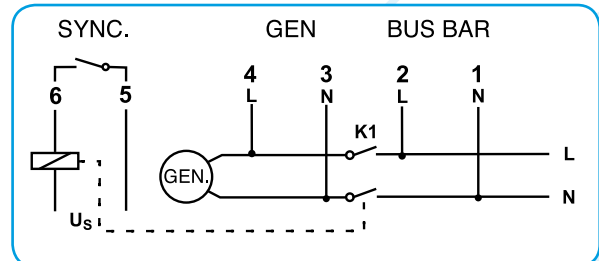

Phase to neutral connection

Connection terminal number	Connection designation	Use of terminal
1	L1 <sup>1)</sup>	System voltage
2	L2 <sup>1)</sup>	System voltage
3	L1 <sup>1)</sup>	Generator voltage
4	L2 <sup>1)</sup>	Generator voltage
5	SYNC.	Relay output
6	SYNC.	Relay output
7	STATUS	Status output
8	STATUS	Status output

<sup>1)</sup> In the case of phase to neutral connection, the connection scheme on the back side of the synchroscope (upper pictures) is different, connection terminal designations are "L" and "N".

Connection diagram for: ZQ 1207, ZQ 1208,  
FQ 1207, FQ 1208, FQ 1108, ZQ 1108

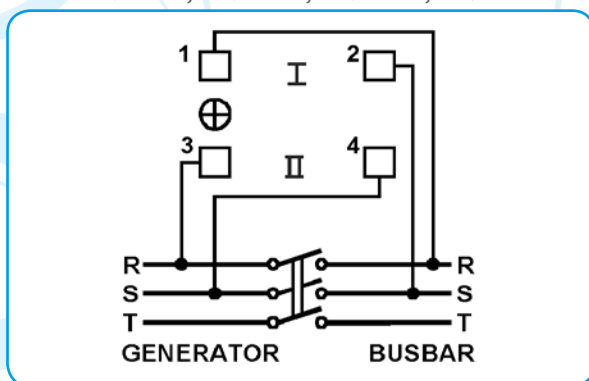

Connection diagram for: CQ 3207

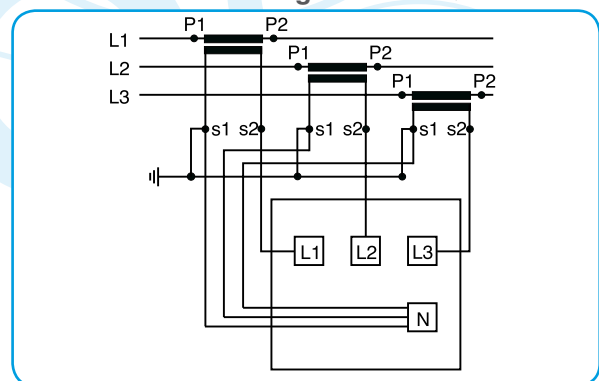

Connection diagram for: FQ 3107, FQ 3207, FQ 3307

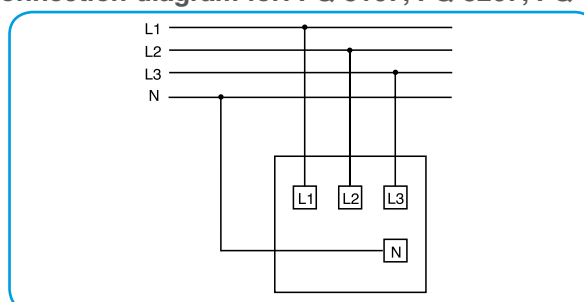

# Instruments Conformity to Standards

## OVERLOADS OF SHORT DURATION

Type of instrument	Range	Test condition		Standard requirements
CQ2207	1A	0.5s ; 25x In	2x Un	According to 60051-1:2000 Direct acting indicating analogue electrical measuring instruments and their accessories - Part 1: Definitions and general requirements common to all parts 10xIn - 9x0,5s+1x5s/60s 2xUn - 9x0,5s+1x5s/60s
CQ2207	1A	0.5s ; 30x In	2x Un	
CQ2207	1A	0.5s ; 50x In	2x Un	
CQ2207	1A	1s ; 25x In	2x Un	
CQ2207	1A	1s ; 30x In	2x Un	
CQ2207	1A	1s ; 50x In	2x Un	
CQ2207	5A	0.5s ; 25x In	2x Un	
CQ2207	5A	0.5s ; 30x In	2x Un	
CQ2207	5A	0.5s ; 40x In	2x Un	
CQ2207	5A	1s ; 25x In	2x Un	
CQ2207	5A	1s ; 30x In	2x Un	
CQ2207	5A	1s ; 40xIn	2x Un	
EQ2207	1A	0.5s ; 25x In	2x Un	
EQ2207	1A	0.5s ; 30x In	2x Un	
EQ2207	1A	0.5s ; 50x In	2x Un	
EQ2207	1A	1s ; 25x In	2x Un	
EQ2207	1A	1s ; 30x In	2x Un	
EQ2207	1A	1s ; 50x In	2x Un	
EQ2207	5A	1s ; 25x In	2x Un	
EQ2207	5A	1s ; 30x In	2x Un	
EQ2207	5A	1s ; 50x In	2x Un	
FQ0207	1A	0.5s ; 25x In	2x Un	
FQ0207	1A	0.5s ; 30x In	2x Un	
FQ0207	1A	0.5s ; 50x In	2x Un	
FQ0207	1A	1s ; 25x In	2x Un	
FQ0207	1A	1s ; 30x In	2x Un	
FQ0207	1A	1s ; 50x In	2x Un	
FQ0207	5A	0.5s ; 25x In	2x Un	
FQ0207	5A	0.5s ; 30x In	2x Un	
FQ0207	5A	0.5s ; 50x In	2x Un	
FQ0207	5A	1s ; 50x In	2x Un	

# Instruments Conformity to Standards

## Type of product

## Conformity to standard

### Measuring centres

MC 760	IEC 62052-11 : 2004 - Electricity metering equipment (ac) General requirements, tests and test conditions Part 11: Metering equipment" IEC 62053-21:2003 - Electricity metering equipment (a.c.) Particular requirements - Part 21: Static meters for active energy (classes 1 and 2) IEC 62053-31:2003 - Electricity metering equipment (a.c.) Particular requirements - Part 31: Pulse output devices for electro mechanical and electronic meters (two wires only) IEC 61010-1: 2001- Safety requirements for electrical equipment for measurement , control and laboratory use - Part 1:
General requirements	IEC 61326-1: 2003 - EMC requirements for electrical equipment for measurement, control and laboratory use - Part 1:
General requirements	IEC 61000-4-5: 2001 - Electromagnetic compatibility (EMC) - Part 4-5: Testing and measurements techniques - Surge immunity test IEC 61000-4-7: 2002 - Electromagnetic compatibility (EMC) - Part 4-7: Testing and measurements techniques - General guide on harmonics and interharmonics measurements and instrumentation, for power supply systems and equipment connected thereto IEC 61000-4-15: 2003 - Electromagnetic compatibility (EMC) - Part 4: Testing and measurements techniques - Section 15: Flickermeter - Functional and design specifications IEC 61000-4-30: 2003 - Electromagnetic compatibility (EMC) - Part 4-30: Testing and measurements techniques - Power quality measurement methods
MC 750, MC 740, MC 754, MC 744	IEC 62052-11 : 2004 - Electricity metering equipment (ac) General requirements, tests and test conditions Part 11: Metering equipment" IEC 62053-21:2003 - Electricity metering equipment (a.c.) Particular requirements - Part 21: Static meters for active energy (classes 1 and 2) IEC 61010-1: 2001 - Safety requirements for electrical equipment for measurement, control and laboratory use - Part 1:
General requirements	IEC 61326-1: 2003 - EMC requirements for electrical equipment for measurement, control and laboratory use - Part 1:
General requirements	IEC 61000-4-5: 2001 - Electromagnetic compatibility (EMC) - Part 4-5: Testing and measurements techniques - Surge immunity test IEC 61010-1: 2001 - Safety requirements for electrical equipment for measurement, control and laboratory use - Part 1:
MC 710	IEC 61326-1: 2003 - EMC requirements for electrical equipment for measurement, control and laboratory use - Part 1:
General requirements	IEC 61000-4-5: 2001 - Electromagnetic compatibility (EMC) - Part 4-5: Testing and measurements techniques - Surge immunity test
Communication adapters	IEC 55024: 2000 - Information technology equipment - Immunity characteristics - Limits and method of measurement (CISPR 24: 1997, modified) IEC 61010-1: 2001 - Safety requirements for electrical equipment for measurement, control and laboratory
MI 480, MI 485, MI 486, MI 488	IEC 61326-1: 2003 - EMC requirements for electrical equipment for measurement, control and laboratory use - Part 1:
use - Part 1: General requirements	IEC 61000-4-3: 1995-2 - Electromagnetic compatibility (EMC) - Part 4: Testing and measurements techniques - Section 3 Radiated, radio-frequency, electromagnetic field immunity test
General requirements	IEC 61000-4-3: 1995-2 - Electromagnetic compatibility (EMC) - Part 4: Testing and measurements techniques - Section 3 Radiated, radio-frequency, electromagnetic field immunity test
Measuring transducers	IEC 688 : 1992 - Electrical measuring transducers for converting a.c. electrical quantities to analog or digital signals EN 61326 : 1997+ Amendment A1 : 1998 - Electrical equipment for measurement, control and laboratory use EMC requirements "EN 61000-6-2 : 1999 - Electromagnetic compatibility ( EMC ) Part 6-2 : Generic standards - Immunity for industrial environments" IEC 61010-1: 2001 - Safety requirements for electrical equipment for measurement, control and laboratory use - Part 1:
MI 400, MI 401, MI 404, MI 413, MI 414, MI 421, MI 436, MI 438	IEC 688 : 1992 - Electrical measuring transducers for converting a.c. electrical quantities to analog or digital signals EN 61326 : 1997+ Amendment A1 : 1998 - Electrical equipment for measurement, control and laboratory use EMC requirements IEC 61010-1: 2001 - Safety requirements for electrical equipment for measurement, control and laboratory use - Part 1:
General requirements	IEC 688 : 1992 - Electrical measuring transducers for converting a.c. electrical quantities to analog or digital signals EN 61326 : 1997+ Amendment A1 : 1998 - Electrical equipment for measurement, control and laboratory use EMC requirements IEC 61010-1: 2001 - Safety requirements for electrical equipment for measurement, control and laboratory use - Part 1:
MT 406 , MT 408, MT 416, MT 418, MT 420	IEC 688 : 1992 - Electrical measuring transducers for converting a.c. electrical quantities to analog or digital signals EN 61326 : 1997+ Amendment A1 : 1998 - Electrical equipment for measurement, control and laboratory use EMC requirements IEC 61010-1: 2001 - Safety requirements for electrical equipment for measurement, control and laboratory use - Part 1:
General requirements	CEI IEC 60770-1 / 1999-02 - Transmitters for use in industrial-process control system CEI IEC 1298-1 / 1995-07 - Process measurements and control devices - General methods and procedures for evaluating performance; • General considerations CEI IEC 1298-2 / 1995-07 - Process measurements and control devices - General methods and procedures for evaluating performance; • Tests under reference conditions CEI IEC 1298-3 / 1995-07 - Process measurements and control devices - General methods and procedures for evaluating performance; •Tests for effects of influence quantities
MI 450, MI 452, MI 454, MI 456 and MI 458	CEI IEC 60770-1 / 1999-02 - Transmitters for use in industrial-process control system CEI IEC 1298-1 / 1995-07 - Process measurements and control devices - General methods and procedures for evaluating performance; • General considerations CEI IEC 1298-2 / 1995-07 - Process measurements and control devices - General methods and procedures for evaluating performance; • Tests under reference conditions CEI IEC 1298-3 / 1995-07 - Process measurements and control devices - General methods and procedures for evaluating performance; •Tests for effects of influence quantities
General requirements	CEI IEC 60770-1 / 1999-02 - Transmitters for use in industrial-process control system CEI IEC 1298-1 / 1995-07 - Process measurements and control devices - General methods and procedures for evaluating performance; • General considerations CEI IEC 1298-2 / 1995-07 - Process measurements and control devices - General methods and procedures for evaluating performance; • Tests under reference conditions CEI IEC 1298-3 / 1995-07 - Process measurements and control devices - General methods and procedures for evaluating performance; •Tests for effects of influence quantities

# Instruments Conformity to Standards

CEI IEC 1298-4 / 1995-07 - Process measurements and control device - General methods and procedures for evaluating performance; • Evaluation report content  
IEC 61010-1: 2001 - Safety requirements for electrical equipment for measurement, control and laboratory use - Part 1:

## General requirements

### Energy meters

WQ 0207, WQ 0217, WQ 1217, WQ 2207

EN61036 : 1996 - Alternating current static watt-hour meters for active energy ( classes 1 and 2 )  
EN61010-1 : 1993 + Amendment A3 : 1995 - Safety requirements for electrical equipment for measurement, control and laboratory use. Part 1 - General requirements

### Synchronization meters

SQ 0204 in SQ 0214

EN60051-5 : 1995 - Direct acting indicating analogue electrical measuring instruments and their accessories. Special requirements for phase meters, power factor meters and synchrosopes.  
EN 61010-1 : 2002 - Safety requirements for electrical equipment for measurement, control and laboratory use. Part 1- General requirements

ZQ 1207

EN 61326 : 1998 - Electrical equipment for measurement, control and laboratory use - EMC requirements  
EN 61326: 1998 - Electrical equipment for measurement, control and laboratory use - EMC requirements  
EN 60051-1: 2000 - Direct acting indicating analogue electrical instruments and their accessories - Part 1: Definitions and general requirements to all parts  
EN 60051-4: 1995 - Direct acting indicating analogue electrical instruments and their accessories - Part 4: Special requirements for frequency meters  
EN 60051-9: 1995 - Direct acting indicating analogue electrical instruments and their accessories - Part 9: Recommended test methods  
EN61010-1 : 2002 - Safety requirements for electrical equipment for measurement, control and laboratory use. Part 1-

### General requirements

FQ 1207

EN 60051-1: 2000 - Direct acting indicating analogue electrical instruments and their accessories - Part 1: Definitions and general requirements to all parts  
EN 60051-2: 1995 - Direct acting indicating analogue electrical instruments and their accessories - Part 2: Special requirements for Ammeters and Voltmeters  
EN 60051-9: 1995 - Direct acting indicating analogue electrical instruments and their accessories - Part 9: Recommended test methods  
EN61010-1 : 2002 - Safety requirements for electrical equipment for measurement, control and laboratory use. Part 1-

### General requirements

### Power meters and power factor meters

EQ 0107, EQ 0207, EQ 2107, EQ 2207,  
YQ 0107, YQ 0207, YQ 2107, YQ 2207

EN 61236 : 1998 - Electrical equipment for measurements, control and laboratory use, EMC requirements  
EN 60051-1 : 2000 - Direct acting indicating analogue electrical measuring instruments and their accessories - Part 1 : Definitions and general requirement  
EN 60051-3: 1995 - Direct acting indicating analogue electrical measuring instruments and their accessories - Part 3 : Special requirements for wattmeters and varimeters  
EN 60051-9: 1995 - Direct acting indicating analogue electrical measuring instruments and their accessories - Part 9 : Recommended test methods  
EN 61010-1 : 2002 - Safety requirements for electrical equipment for measurement, control and laboratory use - Part 1 :

### General requirements

EQ 0307, EQ 2307, YQ 0307, YQ 2307

EN 61236 : 1998 - Electrical equipment for measurements, control and laboratory use, EMC requirements  
EN 60051-1 : 2000 - Direct acting indicating analogue electrical measuring instruments and their accessories - Part 1 : Definitions and general requirements  
EN 60051-3: 1995 - Direct acting indicating analogue electrical measuring instruments and their accessories - Part 3 : Special requirements for wattmeters and varimeters  
EN 60051-5: 1995 - Direct acting indicating analogue electrical measuring instruments and their accessories - Part 5 : Special requirements for phase meters, power factor meters and synchrosopes.  
EN 60051-9: 1995 - Direct acting indicating analogue electrical measuring instruments and their accessories - Part 9 : Recommended test methods  
EN 61010-1 : 2002 - Safety requirements for electrical equipment for measurement, control and laboratory use - Part 1 :

### General requirements

### Frequency meters

ZQ 0207, ZQ 0407, ZQ 0307, ZQ 0107,  
ZQ 2307, ZQ 2207, ZQ 2107  
- General requirements

EN 61326: 1998 - Electrical equipment for measurement, control and laboratory use - EMC requirements  
EN60051-1 1994 - Direct acting indicating analogue electrical measuring instruments and their accessories

- Frequency meters

EN60051-4 1984 - Direct acting indicating analogue electrical measuring instruments and their accessories

- Recommended test methods.

EN60051-9 1988 - Direct acting indicating analogue electrical measuring instruments and their accessories

EN61010-1 : 2002 - Safety requirements for electrical equipment for measurement, control and laboratory use. Part 1-

### General requirements

### Reed frequency meters

ZQ 0317, ZQ 0217, ZQ 0117,  
1217, ZQ 1117

EN 60051-1: 2000 - Direct acting indicating analogue electrical instruments and their accessories - Part 1: Definitions and general requirements to all parts  
EN 60051-4: 1995 - Direct acting indicating analogue electrical instruments and their accessories - Part 4: Special requirements for frequency meters  
EN 60051-9: 1995 - Direct acting indicating analogue electrical instruments and their accessories - Part 9: Recommended test methods  
EN61010-1 : 2002 - Safety requirements for electrical equipment for measurement, control and laboratory use. Part 1-

### General requirements

# Instruments Conformity to Standards

Meters for DC voltage or current with moving coil  
BQ 0107, BQ 0207, BQ 0307,  
BQ 0407, BQ 0507

EN 60051-1: 2000 - Direct acting indicating analogue electrical instruments and their accessories - Part 1: Definitions and general requirements to all parts  
EN 60051-2: 1995 - Direct acting indicating analogue electrical instruments and their accessories - Part 2: Special requirements for Ammeters and Voltmeters  
EN 60051-9: 1995 - Direct acting indicating analogue electrical instruments and their accessories - Part 9: Recommended test methods  
EN61010-1 : 2002 - Safety requirements for electrical equipment for measurement, control and laboratory use. Part 1-

## General requirements

BQ 2107, BQ 2207, BQ 2307, BQ 2407,  
BQ 2507

EN 60051-1: 2000 - Direct acting indicating analogue electrical instruments and their accessories - Part 1: Definitions and general requirements to all parts  
EN 60051-2: 1995 - Direct acting indicating analogue electrical instruments and their accessories - Part 2: Special requirements for Ammeters and Voltmeters  
EN 60051-9: 1995 - Direct acting indicating analogue electrical instruments and their accessories - Part 9: Recommended test methods  
EN61010-1 : 2002 - Safety requirements for electrical equipment for measurement, control and laboratory use. Part 1-

## General requirements

Meters for DC voltage or current with moving coil and rectifier

CQ 0107, CQ 0207, CQ 0307, CQ 0407,  
CQ 0507, CQ 2107, CQ 2207, CQ 2307,  
CQ 2407, CQ 2507

EN 61326: 1998 - Electrical equipment for measurement, control and laboratory use - EMC requirements  
EN 60051-1: 2000 - Direct acting indicating analogue electrical instruments and their accessories - Part 1: Definitions and general requirements to all parts  
EN 60051-2: 1995 - Direct acting indicating analogue electrical instruments and their accessories - Part 2: Special requirements for Ammeters and Voltmeters  
EN 60051-9: 1995 - Direct acting indicating analogue electrical measuring instruments and their accessories  
EN61010-1 : 2002 - Safety requirements for electrical equipment for measurement, control and laboratory use. Part 1-

## General requirements

Meters for AC voltage or current with moving iron

FQ0107, FQ0207, FQ0307,  
FQ0507, FQ0407

EN 60051-1: 2000 - Direct acting indicating analogue electrical instruments and their accessories - Part 1: Definitions and general requirements to all parts  
EN 60051-2: 1995 - Direct acting indicating analogue electrical instruments and their accessories - Part 2: Special requirements for Ammeters and Voltmeters  
EN 60051-9: 1995 - Direct acting indicating analogue electrical instruments and their accessories - Part 9: Recommended test methods  
EN61010-1 : 2002 - Safety requirements for electrical equipment for measurement, control and laboratory use. Part 1-

## General requirements

FQ 3207 in FQ 3307

EN 60051-1: 2000 - Direct acting indicating analogue electrical instruments and their accessories - Part 1: Definitions and general requirements to all parts  
EN 60051-2: 1995 - Direct acting indicating analogue electrical instruments and their accessories - Part 2: Special requirements for Ammeters and Voltmeters  
EN 60051-9: 1995 - Direct acting indicating analogue electrical instruments and their accessories - Part 9: Recommended test methods  
EN61010-1 : 2002 - Safety requirements for electrical equipment for measurement, control and laboratory use. Part 1-

## General requirements

Bimetal maximum current meters

MQ 0507, MQ 0407, MQ 0307,  
MQ 0207, MQ 0107

EN60051-1 1994 - Direct acting indicating analogue electrical measuring instruments and their accessories - General requirements  
EN60051-9 1988 - Direct acting indicating analogue electrical measuring instruments and their accessories - Recommended test methods.  
EN61010-1 : 2002 - Safety requirements for electrical equipment for measurement, control and laboratory use. Part 1-  
General requirements

Combined bimetal maximum current meters

MQ 0117, MQ 0217, MQ 0317

EN60051-1 1994 - Direct acting indicating analogue electrical measuring instruments and their accessories - General requirements  
EN60051-9 1988 - Direct acting indicating analogue electrical measuring instruments and their accessories - Recommended test methods.  
EN 60051-2: 1995 - Direct acting indicating analogue electrical instruments and their accessories - Part 2: Special requirements for Ammeters and Voltmeters  
ESI 50-2 Bimetallic Ammeters  
EN61010-1: 2002 - Safety requirements for electrical equipment for measurement, control and laboratory use. Part 1-  
General requirements

Multimeters

MI 7054

EN 61326: 1998 - Electrical equipment for measurement, control and laboratory use - EMC requirements  
EN60051-1 1994 - Direct acting indicating analogue electrical measuring instruments and their accessories - General requirements  
EN60051-7 1984 - Direct acting indicating analogue electrical measuring instruments and their accessories - Multi-function instruments  
EN60051-9 1988 - Direct acting indicating analogue electrical measuring instruments and their accessories - Recommended test methods.  
EN61010-1 : 2002 - Safety requirements for electrical equipment for measurement, control and laboratory use. Part 1 -  
General requirements

# Instruments Conformity to Standards

MI 7056	<p>EN 61326: 1998 - Electrical equipment for measurement, control and laboratory use - EMC requirements</p> <p>EN60051-1 1994 - Direct acting indicating analogue electrical measuring instruments and their accessories - General requirements</p> <p>EN60051-7 1984 - Direct acting indicating analogue electrical measuring instruments and their accessories - Multi-function instruments</p> <p>EN60051-9 1988 - Direct acting indicating analogue electrical measuring instruments and their accessories - Recommended test methods</p> <p>EN61010-1 : 2002 - Safety requirements for electrical equipment for measurement, control and laboratory use. Part 1 - General requirements</p>
MI 7065	<p>EN 61326: 1998 - Electrical equipment for measurement, control and laboratory use- EMC requirements</p> <p>EN60051-1 1994 - Direct acting indicating analogue electrical measuring instruments and their accessories - General requirements</p> <p>EN60051-7 1984 - Direct acting indicating analogue electrical measuring instruments and their accessories - Multi-function instruments</p> <p>EN60051-9 1988 - Direct acting indicating analogue electrical measuring instruments and their accessories - Recommended test methods</p> <p>EN61010-1 : 2002 - Safety requirements for electrical equipment for measurement, control and laboratory use. Part 1 - General requirements</p>
Educational Programme 07035.00	<p>EN 61326: 1998 - Electrical equipment for measurement, control and laboratory use - EMC requirements</p> <p>EN60051-1 1994 - Direct acting indicating analogue electrical measuring instruments and their accessories - General requirements</p> <p>EN60051-7 1984 - Direct acting indicating analogue electrical measuring instruments and their accessories - Multi-function instruments</p> <p>EN60051-9 1988 - Direct acting indicating analogue electrical measuring instruments and their accessories - Recommended test methods</p> <p>EN61010-1 : 2002 - Safety requirements for electrical equipment for measurement, control and laboratory use. Part 1 - General requirements</p>
07038.00	<p>EN 61326: 1998 - Electrical equipment for measurement, control and laboratory use - EMC requirements</p> <p>EN60051-1 1994 - Direct acting indicating analogue electrical measuring instruments and their accessories - General requirements</p> <p>EN60051-2 1984 - Direct acting indicating analogue electrical measuring instruments and their accessories - Special requirements for ammeters and voltmeters</p> <p>EN60051-9 1988 - Direct acting indicating analogue electrical measuring instruments and their accessories - Recommended test methods</p> <p>EN61010-1 : 2002 - Safety requirements for electrical equipment for measurement, control and laboratory use. Part 1 - General requirements</p>
07021.01	<p>EN 61326: 1998 - Electrical equipment for measurement, control and laboratory use - EMC requirements</p> <p>EN60051-1 1994 - Direct acting indicating analogue electrical measuring instruments and their accessories - General requirements</p> <p>EN60051-7 1984 - Direct acting indicating analogue electrical measuring instruments and their accessories - Multi-function instruments</p> <p>EN60051-9 1988 - Direct acting indicating analogue electrical measuring instruments and their accessories - Recommended test methods.</p> <p>EN61010-1 : 2002 - Safety requirements for electrical equipment for measurement, control and laboratory use. Part 1 - General requirements</p>
07026.00	<p>EN 61326: 1998 - Electrical equipment for measurement, control and laboratory use - EMC requirements</p> <p>EN60051-1 1994 - Direct acting indicating analogue electrical measuring instruments and their accessories - General requirements</p> <p>EN60051-7 1984 - Direct acting indicating analogue electrical measuring instruments and their accessories - Multi-function instruments</p> <p>EN60051-9 1988 - Direct acting indicating analogue electrical measuring instruments and their accessories - Recommended test methods.</p> <p>EN61010-1 : 2002 - Safety requirements for electrical equipment for measurement, control and laboratory use. Part 1 - General requirements</p>
<b>Digital temperature meters</b> MI 7022	<p>EN 61326 : 1998 - Electrical equipment for measurement, control and laboratory use - EMC requirements A1:1998 Amendment A1</p>
Shunts	<p>AR 0101 EN 60051-1: 2000 - Direct acting indicating analogue electrical instruments and their accessories - Part 1: Definitions and general requirements to all parts</p> <p>EN 60051-8: 1995 - Direct acting indicating analogue electrical instruments and their accessories - Part 8: Special requirements for accessories.</p> <p>EN 60051-9: 1995 - Direct acting indicating analogue electrical instruments and their accessories - Part 9: Recommended test methods</p> <p>EN61010-1 : 2002 - Safety requirements for electrical equipment for measurement, control and laboratory use. Part 1-</p>
General requirements.	
<b>Common standards</b>	<p>DIN 43701 : measuring ratings</p> <p>IEC 61554:1999 Electrical measuring instruments-dimensions for panel mounting</p> <p>DIN 43802 : pointers , scales</p> <p>DIN1451 : inscriptions</p> <p>EN 60529:1997 Degrees of protection provided enclosures (IP code)</p> <p>UL 94V-0 : self extinguishable materials</p> <p>EN 61010-1:2002 Safety requirements for electrical equipment for measurement, control and laboratory use</p> <p>EN 61036:1998/A1:2001 Alternating current static watt-hour meters for active energy (Razreds 1 and 2)</p> <p>DIRECTIVE 2002/96/EC of 27 January 2003 on waste electrical and electronic equipment (WEEE)</p> <p>DIRECTIVE 2002/95/EC of 27 January 2003 on the restriction of the use of certain hazardous substances in EEE</p> <p>Installation categories according to standard EN 61010-1 and data on the label on the instrument.</p>



**Iskra**®

**Iskra Sistemi**

Iskra Sistemi, d. d., Stegne 21, SI-1000 Ljubljana  
Tel.: +386 1 513 10 00, Fax: +386 1 511 15 32  
E-mail: [info@iskrasistemi.si](mailto:info@iskrasistemi.si), [www.iskrasistemi.si](http://www.iskrasistemi.si)