

Protistor® Fuse Microswitches

Microswitch systems for round and square-body fuses (not for PSC fuses)

The Protistor fuse microswitch is a remote signaling system designed to fit on round and square body Protistor fuses (not for PSC fuses) that are equipped with microswitch support. It indicates fuse status and has a manual reset feature.

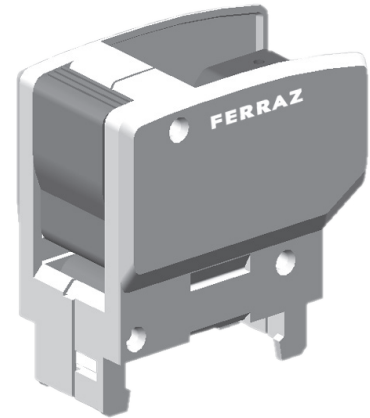

Features/Benefits:

- Remote signaling systems for fitting on Mersen fuses equipped with microswitch support
- Indication of fuse status
- Manual reset
- Standard and low current models with different insulation ratings
- Watertight types for use in corrosive atmospheres

Characteristics

Type	Catalog Number	AC or DC Insulation Voltage Rating Ui (V)	AC Voltage Withstand Test (.)	Impulse Voltage Test Uimp 1,2/50 hs (..)	Positive Operating Min. Voltage / Min. Current	Current Rating	Current	Non-indicating Circuit			Indicating Circuit L/R=25ms			
								30V	110V	250V	30V	100V	250V	
Standard	MC3E 1-5N	1250V	15 kV	20 kV	20 V	5A	50/60 Hz	10 A	10 A	7 A			6 A	
	MCR3E 1-5N	2200V	20 kV	30 kV	50 mA		DC	5 A	0.5 A		1.6 A	0.3 A		
Low Level	MC3E 1-5NBS	1250V	15 kV		10 V 10 mA	3A	50/60 Hz							
	MC3E 1-9NBS	1250V	15 kV	20 kV				3 A	3 A	3 A	2 A	1 A	1 A	
	MCR3E 1-5NBS	2200V	20 kV (1)											
	MCR3E 1-9NBS	2200V	23 kV (2)	30 kV										
	MC2R3E 1-5BS	6000V	24 kV (1)					DC	3 A	0.5 A	0.25 A	3 A	0.2 A	0.1 A
	MC2R3E 1-9NBS	6000V	26 kV (2)	40 kV										
Watertight IP 50	MC3E 1-5NET	1250V	32 kV (3)	16 kV	10 V	3A	50 Hz		3 A	3 A		1 A	1 A	
	MCR3E 1-5NET	2200V	11 kV	30 kV	10 mA		DC		0.5A			0.2 A		
	MC2R3E 1-5NET	6000V	20 kV (1)	40 kV										

Catalog numbering system: MC3E 1-5 single pole microswitch - MC3E 1-9 double pole microswitch - MCR, MC2R reinforced insulation microswitch

* Between power circuit and microswitch terminals as per IEC 60 and 694 and NFC 64010 (50/60 Hz 1 min. duration in dry air)

** Between power circuit and microswitch terminals Uimp: impulse voltage according to IEC 947-1

***Between power circuit and microswitch terminals

EACH MICROSWITCH WEIGHS LESS THAN 100g, THEREFORE NO FUME AND SMOKE GRADE IS REQUIRED BY NF F16-102 STANDARD

(1) for short body fuses (sizes 30 - 31 - 32 - 33 - 70 - 71 - 72 - 73 - 83 - 84) Except PSC

(2) for sizes 100 - 91 - 92 - 93 - 94 - 123 - 124 fuses and longer

(3) for sizes 171 - 172 - 173 - 174 fuses and longer

Protistor® Fuse Microswitches

Remote Signaling with 1250 V AC/DC Insulation Voltage

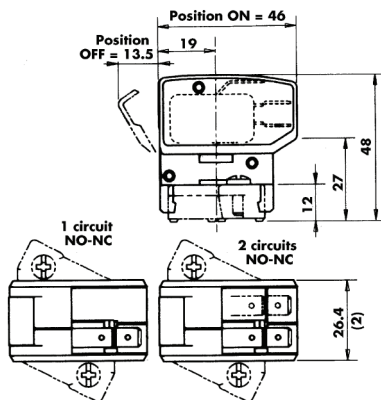

Quantity of NO-NC separated circuits	Contact	Catalog Number	Ref. Number	Weight (g)	Pack. (1)
1	standard	MC3E 1-5N	D310020	39.5	3
1	low level	MC3E 1-5NBS	E310021	39.5	3
2	low level	MC3E 1-9NBS	F310022	45.7	3
1	watertight	MC3E 1-5NET	L310027	40.2	3

Remote Signaling with Insulation Voltage up to 2200 V AC/DC

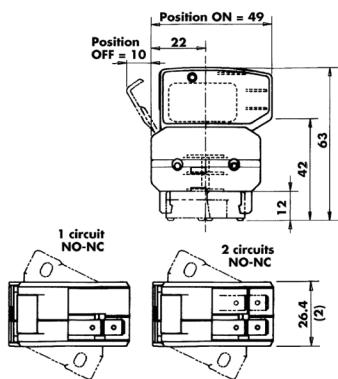

Quantity of NO-NC separated circuits	Contact	Catalog Number	Ref. Number	Weight (g)	Pack. (1)
1	standard	MCR3E 1-5N	G310023	51.7	1
1	low level	MC3RE 1-5NBS	P310030	51.7	1
2	low level	MCR3E 1-9NBS	H310024	58.0	1
1	watertight	MCR3E 1-5NET	Q310031	52.5	1

Remote Signaling with Insulation Voltage up to 6000 V AC/DC

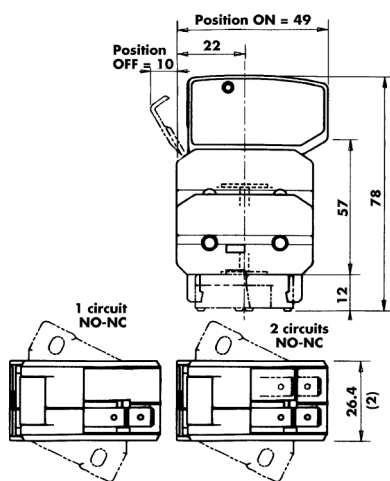

Quantity of NO-NC separated circuits	Contact	Catalog Number	Ref. Number	Weight (g)	Pack. (1)
1	low level	MC2R3E 1-5NBS	J310025	64.0	1
1	watertight	MC2R3E 1-5NET	N310029	64.8	1
2	low level	MC2R3E 1-9NBS	K310026	70.3	1

Electrical diagram of each microswitch circuit

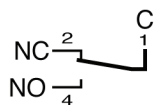

Non-blown fuse
Microswitch ON

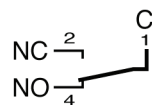

Blown fuse
Microswitch OFF

All of these signaling systems are resettable and fitted with silver-plated 3-terminal microswitch C, NO and NC. The C terminal is on the top and connection is made via 6.35 mm clips except for watertight models whose clips are 4.8 mm wide

NOTE (2): The 26.4 dimension is the same with 1 or 2 separated circuits NO-NC.
 Tests with sine vibrations carried out at ambient with scanning of the three main holder axes.
 Spectrum: 1st segment (2 to 16 Hz) constant trip $x = 5$ mm peak.
 2nd segment (16 to 250 Hz) constant acceleration $y + 5$ g peak

Exponential scanning speed: 1 octave per minute.
 Duration: 2 hours per axis.