

Terminal blocks spring clamp

for distribution boxes

DIN 3



Disconnect function view

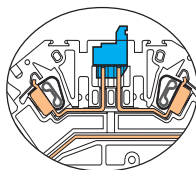

End stop		th. 9 mm	BADL	V0	1SNA 399 903 R0200
End stop		th. 10 mm	BAM2 V0	V0	1SNA 399 967 R0100
End stop		th. 12 mm	BADH	V2	1SNA 116 900 R2700
End stop		th. 9,1 mm	BAMH	V2	1SNA 114 836 R0000
End stop		th. 9,1 mm	BAMH V0	V0	1SNA 194 836 R0100
Rail		35 x 7,5 x 1	PR3.Z2		1SNA 174 300 R1700
Rail		35 x 15 x 2,3	PR4		1SNA 168 500 R1200
Rail		35 x 15 x 1,5	PR5		1SNA 168 700 R2200

Other end stops, rails and accessories : see section on accessories.

Notes

The use of some accessories may decrease the block's voltage rating. For more information, consult us.

- * Blue marking on "neutral" circuit.
- Yellow/green marking on "ground" circuit.

One wire per spring.
UL 94 V0 material.

Accessories

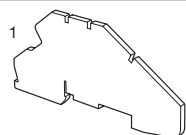

- 1 End section grey
- 2 Jumper bar orange
IP 20 - 24 A

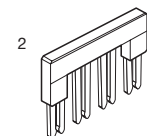

R See section on markers marking method

D 2,5/5.A.NTLP.L

Spacing 5 mm +0,05 .198"

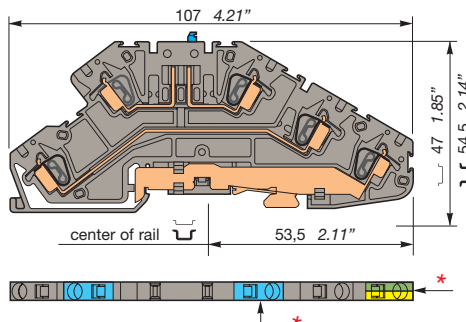

Colour	Type	Part number
Grey V0	□	D 2,5/5.A.NTLP.L 1SNA 290 336 R0700

Characteristics

Wire size	IEC		UL/CSA
	NFC	DIN	
Rigid	(1) 0,14-4 mm ²		26-12 AWG
Flexible	0,14-2,5 mm ²		26-12 AWG
Isolating cover	0,5-2,5 mm ²		
Ground bar			
Voltage			
Rated	(2) 400 V / 250 V		300 V
Impulse withstand	(3) 6 kV / 4 kV		
Pollution degree	3		
Current			
Rated	Short circuit	20 A	300 A / 1s.
Wire size			
Rated / Gauge	2,5 mm ² / A2		12 AWG
Wire strip length	Recomm. screwdriver	Weight	Protection
9,5 mm	3,5 mm	20 g	IP 20
.37"	.14"	.71 oz	NEMA 1

Type	Part numbers
FEDA5.L V0 th. 2,5 mm	1SNA 291 561 R2600
BJDL5.2 V0 2 poles	1SNA 291 102 R2300
BJDL5.3 V0 3 poles	1SNA 291 103 R2400
BJDL5.4 V0 4 poles	1SNA 291 104 R2500
BJDL5.5 V0 5 poles	1SNA 291 105 R2600
BJDL5.6 V0 6 poles	1SNA 291 106 R2700
BJDL5.7 V0 7 poles	1SNA 291 107 R2000
BJDL5.8 V0 8 poles	1SNA 291 108 R0100
BJDL5.9 V0 9 poles	1SNA 291 109 R0200
BJDL5.10 V0 10 poles	1SNA 291 110 R2600

- (1) Entelec's spring terminal blocks with 5 mm spacing are compliant with IEC 947-1 standard for 2.5 mm² wire size. However, terminal blocks can also be connected to 4 mm² rigid wires.
- (2) Phase to phase = 400 V - Phase to ground = 250 V
- (3) Phase to phase = 6 kV - Phase to ground = 4 kV

RC55

Interruptible neutral : Why ?

Example : fault on a TN-S network (1 neutral cable, 1 ground cable, both connected at the transformer)

Fault ① : fault between one phase and the device (e.g. industrial oven) frame
It is a direct phase to ground fault. The fuse operates and the fault is identified.

Fault ② : fault limited by the load impedance - use of neutral interruptible function
In this case, there is no direct phase to ground short-circuit and the fuse will not operate. There is a fault current on the ground path limited by the load impedance. Despite the apparent correct operation of the device, there is a potential danger for the users.

Test procedure for fault location :

- 1- Isolate the power transformer from the installation by operating the main disconnect switch.
- 2- Insert an ohmmeter between neutral and ground before the distribution point to the different devices (as it is not possible to detect the origin of the fault if several devices are connected on the same circuit).
- 3- Open the interruptible neutral levers one by one.
- 4- When the faulty circuit is opened, the ohmmeter shows an infinite impedance. The fault is then identified.

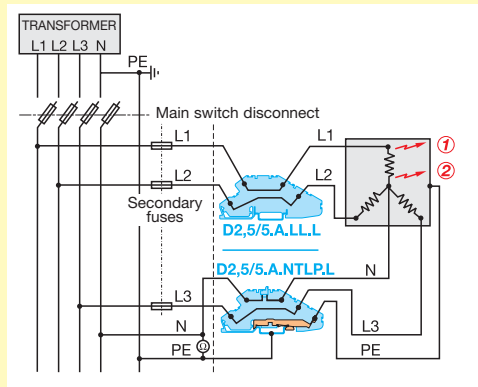

Terminal blocks spring clamp

for distribution boxes

DIN 3

End stop		th. 9 mm	BADL	V0	1SNA 399 903 R0200
End stop		th. 10 mm	BAM2 V0	V0	1SNA 399 967 R0100
End stop		th. 12 mm	BADH	V2	1SNA 116 900 R2700
End stop		th. 9,1 mm	BAMH	V2	1SNA 114 836 R0000
End stop		th. 9,1 mm	BAMH V0	V0	1SNA 194 836 R0100
Rail		35 x 7,5 x 1	PR3.Z2		1SNA 174 300 R1700
Rail		35 x 15 x 2,3	PR4		1SNA 168 500 R1200
Rail		35 x 15 x 1,5	PR5		1SNA 168 700 R2200

Other end stops, rails and accessories : see section on accessories.

Notes

The use of some accessories may decrease the block's voltage rating. For more information, consult us.

- * Blue marking on "neutral" circuit.
- Yellow/green marking on "ground" circuit.

One wire per spring.
UL 94 V0 material.

Accessories

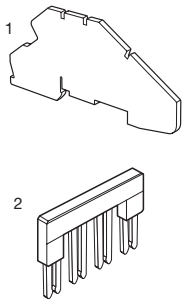

- 1 End section grey
- 2 Jumper bar orange
IP 20 - 24 A



R See section on markers marking method

D 2,5/5.A.NLP.L

Spacing 5 mm +0,05 .198"

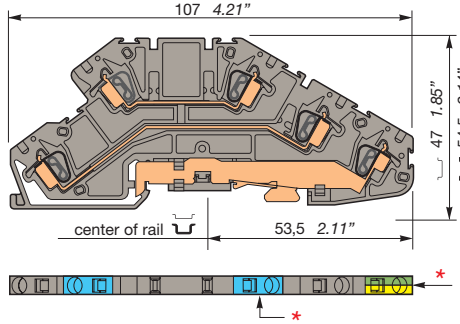

Colour	Type	Part number
Grey V0	D 2,5/5.A.NLP.L	1SNA 290 338 R1100

Characteristics

Wire size	IEC		UL/CSA
	NFC	DIN	
Rigid	(1) 0,14-4 mm ²		26-12 AWG
Flexible	0,14-2,5 mm ²		26-12AWG
Isolating cover			
Ground bar			
Voltage			
Rated		(1) 400 V / 250 V	300 V
Impulse withstand		(2) 6 kV / 4 kV	
Pollution degree		3	
Current			
Rated	Short circuit	24 A	300 A /1s. 20 A
Wire size			
Rated / Gauge		2,5 mm ² / A2	12 AWG
Wire strip. length	Recomm. screwdriver	Weight	Protection
9,5 mm	3,5 mm	19 g	IP 20
.37"	.14"	.67 oz	NEMA 1

Type	Part numbers
FEDA5.L V0 th. 2,5 mm	1SNA 291 561 R2600
BJDL5.2 V0 2 poles	1SNA 291 102 R2300
BJDL5.3 V0 3 poles	1SNA 291 103 R2400
BJDL5.4 V0 4 poles	1SNA 291 104 R2500
BJDL5.5 V0 5 poles	1SNA 291 105 R2600
BJDL5.6 V0 6 poles	1SNA 291 106 R2700
BJDL5.7 V0 7 poles	1SNA 291 107 R2000
BJDL5.8 V0 8 poles	1SNA 291 108 R0100
BJDL5.9 V0 9 poles	1SNA 291 109 R0200
BJDL5.10 V0 10 poles	1SNA 291 110 R2600

- (1) Entelec's spring terminal blocks with 5 mm spacing are compliant with IEC 947-1 standard for 2.5 mm² wire size. However, terminal blocks can also be connected to 4 mm² rigid wires.
- (2) Phase to phase = 400 V - Phase to ground = 250 V
- (3) Phase to phase = 6 kV - Phase to ground = 4 kV

RC55

D 2,5/5.A.LLP.L

Spacing 5 mm +0,05 .198"

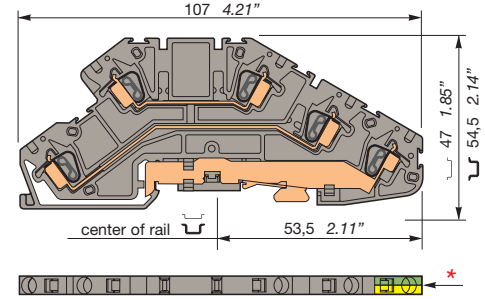

Colour	Type	Part number
Grey V0	D 2,5/5.A.LLP.L	1SNA 290 340 R2700

Characteristics

Wire size	IEC		UL/CSA
	NFC	DIN	
Rigid	(1) 0,14-4 mm ²		26-12 AWG
Flexible	0,14-2,5 mm ²		26-12AWG
Isolating cover			
Ground bar			
Voltage			
Rated		(1) 400 V / 250 V	300 V
Impulse withstand		(2) 6 kV / 4 kV	
Pollution degree		3	
Current			
Rated	Short circuit	24 A	300 A /1s. 20 A
Wire size			
Rated / Gauge		2,5 mm ² / A2	12 AWG
Wire strip. length	Recomm. screwdriver	Weight	Protection
9,5 mm	3,5 mm	19 g	IP 20
.37"	.14"	.67 oz	NEMA 1

Type	Part numbers
FEDA5.L V0 th. 2,5 mm	1SNA 291 561 R2600
BJDL5.2 V0 2 poles	1SNA 291 102 R2300
BJDL5.3 V0 3 poles	1SNA 291 103 R2400
BJDL5.4 V0 4 poles	1SNA 291 104 R2500
BJDL5.5 V0 5 poles	1SNA 291 105 R2600
BJDL5.6 V0 6 poles	1SNA 291 106 R2700
BJDL5.7 V0 7 poles	1SNA 291 107 R2000
BJDL5.8 V0 8 poles	1SNA 291 108 R0100
BJDL5.9 V0 9 poles	1SNA 291 109 R0200
BJDL5.10 V0 10 poles	1SNA 291 110 R2600

- (1) Entelec's spring terminal blocks with 5 mm spacing are compliant with IEC 947-1 standard for 2.5 mm² wire size. However, terminal blocks can also be connected to 4 mm² rigid wires.
- (2) Phase to phase = 400 V - Phase to ground = 250 V
- (3) Phase to phase = 6 kV - Phase to ground = 4 kV

RC55

Terminal blocks spring clamp

for distribution boxes

↳ DIN 3

End stop		th. 9 mm	BADL	V0	1SNA 399 903 R0200
End stop		th. 10 mm	BAM2 V0	V0	1SNA 399 967 R0100
Rail		35 x 7,5 x 1	PR3.Z2		1SNA 174 300 R1700
Rail		35 x 15 x 2,3	PR4		1SNA 168 500 R1200
Rail		35 x 15 x 1,5	PR5		1SNA 168 700 R2200

Other end stops, rails and accessories : see section on accessories.

Notes

The use of some accessories may decrease the block's voltage rating. For more information, consult us.

- * Blue marking on "neutral" circuit.
- Yellow/green marking on "ground" circuit.

One wire per spring.
UL 94 V0 material.

Accessories

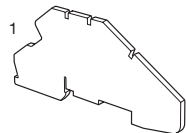

- 1 End section grey
- 2 Jumper bar orange
IP 20 - 24 A

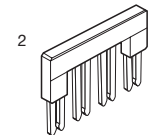

R See section on markers marking method



D 2,5/5.A.NL.L

Spacing 5 mm +0,05 .198"

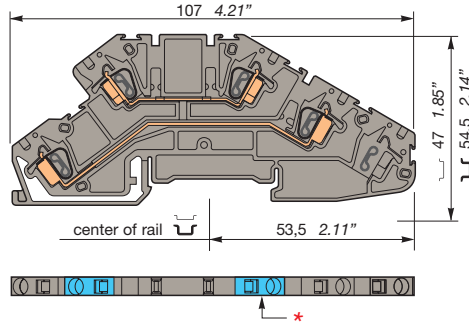

Colour	Type	Part number
1 circuit : "neutral"		
1 circuit : "feed-through"		
Grey V0	D 2,5/5.A.NL.L	1SNA 290 344 R1700

Characteristics

Wire size	IEC		UL/CSA
	NFC	DIN	
Rigid	(1) 0,14-4 mm ²		26-12 AWG
Flexible	0,14-2,5 mm ²		26-12AWG
Isolating cover	0,5-2,5 mm ²		
Ground bar			
Voltage			
Rated	400 V		300 V
Impulse withstand	6 kV		
Pollution degree	3		
Current			
Rated	24 A		20 A
Wire size			
Rated / Gauge	2,5 mm ² / A2		12 AWG
Wire strip. length	Recomm. screwdriver	Weight	Protection
9,5 mm	3,5 mm	15 g	IP 20
.37"	.14"	.53 oz	NEMA 1

D 2,5/5.A.LL.L

Spacing 5 mm +0,05 .198"

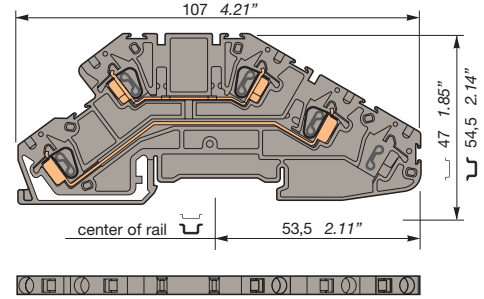

Colour	Type	Part number
2 circuits : "feed-through"		
Grey V0	D 2,5/5.A.LL.L	1SNA 290 342 R1500

Characteristics

Wire size	IEC		UL/CSA
	NFC	DIN	
Rigid	(1) 0,14-4 mm ²		26-12 AWG
Flexible	0,14-2,5 mm ²		26-12AWG
Isolating cover	0,5-2,5 mm ²		
Ground bar			
Voltage			
Rated	400 V		300 V
Impulse withstand	6 kV		
Pollution degree	3		
Current			
Rated	24 A		20 A
Wire size			
Rated / Gauge	2,5 mm ² / A2		12 AWG
Wire strip. length	Recomm. screwdriver	Weight	Protection
9,5 mm	3,5 mm	15 g	IP 20
.37"	.14"	.53 oz	NEMA 1

Type	Part numbers
FEDA5.L V0 th. 2,5 mm	1SNA 291 561 R2600
BJDL5.2 V0 2 poles	1SNA 291 102 R2300
BJDL5.3 V0 3 poles	1SNA 291 103 R2400
BJDL5.4 V0 4 poles	1SNA 291 104 R2500
BJDL5.5 V0 5 poles	1SNA 291 105 R2600
BJDL5.6 V0 6 poles	1SNA 291 106 R2700
BJDL5.7 V0 7 poles	1SNA 291 107 R2000
BJDL5.8 V0 8 poles	1SNA 291 108 R0100
BJDL5.9 V0 9 poles	1SNA 291 109 R0200
BJDL5.10 V0 10 poles	1SNA 291 110 R2600

Type	Part numbers
FEDA5.L V0 th. 2,5 mm	1SNA 291 561 R2600
BJDL5.2 V0 2 poles	1SNA 291 102 R2300
BJDL5.3 V0 3 poles	1SNA 291 103 R2400
BJDL5.4 V0 4 poles	1SNA 291 104 R2500
BJDL5.5 V0 5 poles	1SNA 291 105 R2600
BJDL5.6 V0 6 poles	1SNA 291 106 R2700
BJDL5.7 V0 7 poles	1SNA 291 107 R2000
BJDL5.8 V0 8 poles	1SNA 291 108 R0100
BJDL5.9 V0 9 poles	1SNA 291 109 R0200
BJDL5.10 V0 10 poles	1SNA 291 110 R2600

(1) Entelec's spring terminal blocks with 5 mm spacing are compliant with IEC 947-1 standard for 2.5 mm² wire size. However, terminal blocks can also be connected to 4 mm² rigid wires.

(1) Entelec's spring terminal blocks with 5 mm spacing are compliant with IEC 947-1 standard for 2.5 mm² wire size. However, terminal blocks can also be connected to 4 mm² rigid wires.

RC55

Terminal blocks spring clamp for distribution boxes

DIN 3

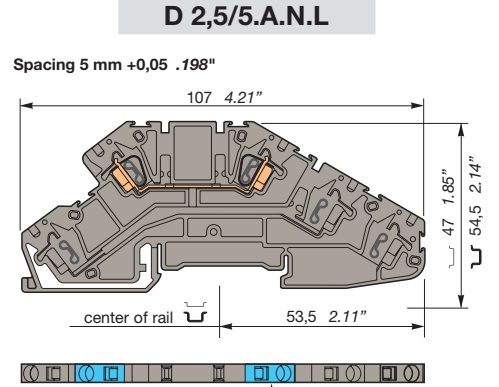
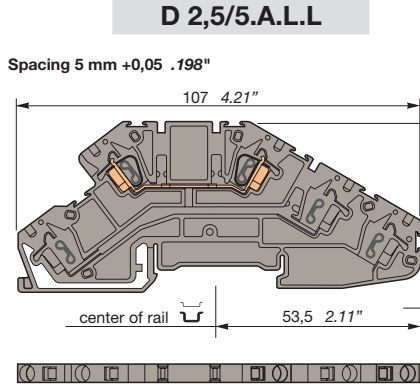

Colour	Type	Part number
Grey V0 (*)	D 2,5/5.A.L.L.	1SNA 290 348 R2300
Grey V0 (**)	D 2,5/5.A.L.L.	1SNA 290 402 R0300

Colour	Type	Part number
Grey V0	D 2,5/5.A.N.L.	1SNA 290 346 R1100

Characteristics			
Wire size	IEC		UL/CSA
	NFC	DIN	
Rigid	(1) 0,14-4 mm ²		26-12 AWG
Flexible	0,14-2,5 mm ²		26-12 AWG
Isolating cover			
Ground bar			
Voltage			
Rated	400 V		300 V
Impulse withstand	6 kV		
Pollution degree	3		
Current			
Rated	24 A		20 A
Wire size			
Rated / Gauge	2,5 mm ² / A2		12 AWG
Wire strip. length	Recomm. screwdriver	Weight	Protection
9,5 mm	3,5 mm	12 g	IP 20
.37"	.14"	.42 oz	NEMA 1

Characteristics			
Wire size	IEC		UL/CSA
	NFC	DIN	
Rigid	(1) 0,14-4 mm ²		26-12 AWG
Flexible	0,14-2,5 mm ²		26-12 AWG
Isolating cover			
Ground bar			
Voltage			
Rated	400 V		300 V
Impulse withstand	6 kV		
Pollution degree	3		
Current			
Rated	24 A		20 A
Wire size			
Rated / Gauge	2,5 mm ² / A2		12 AWG
Wire strip. length	Recomm. screwdriver	Weight	Protection
9,5 mm	3,5 mm	12 g	IP 20
.37"	.14"	.42 oz	NEMA 1

End stop	th. 9 mm	BADL	V0	1SNA 399 903 R0200
End stop	th. 10 mm	BAM2 V0	V0	1SNA 399 967 R0100
End stop	th. 12 mm	BADH	V2	1SNA 116 900 R2700
End stop	th. 9,1 mm	BAMH	V2	1SNA 114 836 R0000
End stop	th. 9,1 mm	BAMH V0	V0	1SNA 194 836 R0100
Rail	35 x 7,5 x 1	PR3.Z2		1SNA 174 300 R1700
Rail	35 x 15 x 2,3	PR4		1SNA 168 500 R1200
Rail	35 x 15 x 1,5	PR5		1SNA 168 700 R2200

Other end stops, rails and accessories : see section on accessories.

Notes
The use of some accessories may decrease the block's voltage rating. For more information, consult us.
* Blue marking on "neutral" circuit.
Yellow/green marking on "ground" circuit.

One wire per spring.
UL 94 V0 material.

Accessories

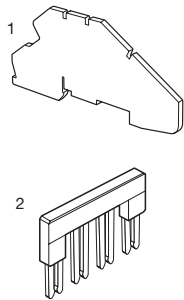

- 1 End section grey
- 2 Jumper bar orange IP 20 - 24 A

Type	Part numbers		
FEDA5.L V0	th. 2,5 mm	1SNA 291 561 R2600	
BJDL5.2 V0	2 poles	1SNA 291 102 R2300	
BJDL5.3 V0	3 poles	1SNA 291 103 R2400	
BJDL5.4 V0	4 poles	1SNA 291 104 R2500	
BJDL5.5 V0	5 poles	1SNA 291 105 R2600	
BJDL5.6 V0	6 poles	1SNA 291 106 R2700	
BJDL5.7 V0	7 poles	1SNA 291 107 R2000	
BJDL5.8 V0	8 poles	1SNA 291 108 R0100	
BJDL5.9 V0	9 poles	1SNA 291 109 R0200	
BJDL5.10 V0	10 poles	1SNA 291 110 R2600	

Type	Part numbers		
FEDA5.L V0	th. 2,5 mm	1SNA 291 561 R2600	
BJDL5.2 V0	2 poles	1SNA 291 102 R2300	
BJDL5.3 V0	3 poles	1SNA 291 103 R2400	
BJDL5.4 V0	4 poles	1SNA 291 104 R2500	
BJDL5.5 V0	5 poles	1SNA 291 105 R2600	
BJDL5.6 V0	6 poles	1SNA 291 106 R2700	
BJDL5.7 V0	7 poles	1SNA 291 107 R2000	
BJDL5.8 V0	8 poles	1SNA 291 108 R0100	
BJDL5.9 V0	9 poles	1SNA 291 109 R0200	
BJDL5.10 V0	10 poles	1SNA 291 110 R2600	

(1) Entelec's spring terminal blocks with 5 mm spacing are compliant with IEC 947-1 standard for 2.5 mm² wire size. However, terminal blocks can also be connected to 4 mm² rigid wires.

(1) Entelec's spring terminal blocks with 5 mm spacing are compliant with IEC 947-1 standard for 2.5 mm² wire size. However, terminal blocks can also be connected to 4 mm² rigid wires.



R See section on markers marking method

RC55

RC55

Terminal blocks spring clamp

for distribution boxes

DIN 3

Product range compatible with
neutral busbar

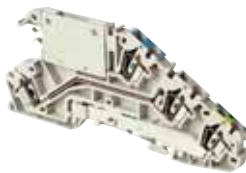

Disconnected from busbar

Connected to busbar

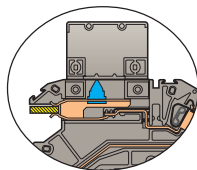
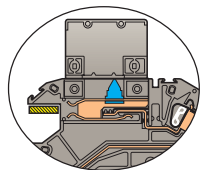

End stop	th. 9 mm	BADL	V0	1SNA 399 903 R0200
End stop	th. 10 mm	BAM2 V0	V0	1SNA 399 967 R0100
Rail	35 x 7,5 x 1	PR3.Z2		1SNA 174 300 R1700
Rail	35 x 15 x 2,3	PR4		1SNA 168 500 R1200
Rail	35 x 15 x 1,5	PR5		1SNA 168 700 R2200

Other end stops, rails and accessories : see section on accessories.

Notes

The use of some accessories may decrease the block's voltage rating. For more information, consult us.

- * Blue marking on "neutral" circuit.
- Yellow/green marking on "ground" circuit.

One wire per spring.
UL 94 V0 material.

Accessories

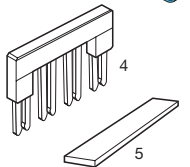
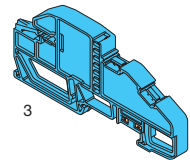
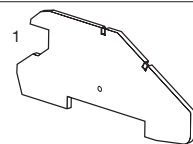

1	End section	grey	FED5.L.A	V0	th. 2,5 mm	1SNA 291 559 R0400
3	Neutral bar end section holder (4)		SPBO.NT.L	V0		1SNA 399 886 R2100
4	Jumper bar IP 20 - 24 A	orange	BJDL5.2	V0	2 poles	1SNA 291 102 R2300
			BJDL5.3	V0	3 poles	1SNA 291 103 R2400
			BJDL5.4	V0	4 poles	1SNA 291 104 R2500
			BJDL5.5	V0	5 poles	1SNA 291 105 R2600
			BJDL5.6	V0	6 poles	1SNA 291 106 R2700
			BJDL5.7	V0	7 poles	1SNA 291 107 R2000
			BJDL5.8	V0	8 poles	1SNA 291 108 R0100
			BJDL5.9	V0	9 poles	1SNA 291 109 R0200
			BJDL5.10	V0	10 poles	1SNA 291 110 R2600
5	Busbar		BO3		10 x 3 mm	1SNA 164 406 R2400
6	Clamp for busbar		SFB1		0,5 to 35 mm ² - H = 7	1SNA 163 860 R0500
			SFB2		16 to 35 mm ² - H = 3	1SNA 168 956 R0600
R	See section on markers marking method		RC55			

D 2,5/5.NTLP.L

Spacing 5 mm +0,05 .198"

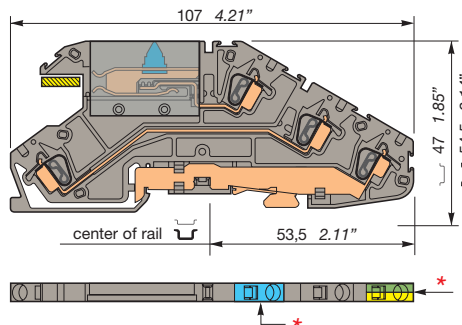

Colour	Type	Part number
Grey V0	D 2,5/5.NTLP.L	1SNA 290 322 R0100

1 circuit : "disconnect neutral" with busbar connection
 1 circuit : "feed-through"
 1 circuit : "ground" connected to the rail

Characteristics

Wire size	IEC		UL/CSA
	NFC	DIN	
Rigid	(1) 0,14-4 mm ²		26-12 AWG
Flexible	0,14-2,5 mm ²		26-12AWG
Isolating cover	0,5-2,5 mm ²		
Ground bar	10 x 3 mm		

Voltage		
Rated	(2) 400 V / 250 V	300 V
Impulse withstand	(3) 6 kV / 4 kV	
Pollution degree	3	

Current		
Rated	Short circuit	20 A
		300 A / 1s.
		20 A

Wire size		
Rated / Gauge	2,5 mm ² / A2	12 AWG

Wire strip length	Recomm. screwdriver	Weight	Protection
9,5 mm	3,5 mm	16 g	IP 20
.37"	.14"	.56 oz	NEMA 1

Type	Part numbers
FED5.L.A	V0 th. 2,5 mm 1SNA 291 559 R0400
SPBO.NT.L	V0 1SNA 399 886 R2100
BJDL5.2	V0 2 poles 1SNA 291 102 R2300
BJDL5.3	V0 3 poles 1SNA 291 103 R2400
BJDL5.4	V0 4 poles 1SNA 291 104 R2500
BJDL5.5	V0 5 poles 1SNA 291 105 R2600
BJDL5.6	V0 6 poles 1SNA 291 106 R2700
BJDL5.7	V0 7 poles 1SNA 291 107 R2000
BJDL5.8	V0 8 poles 1SNA 291 108 R0100
BJDL5.9	V0 9 poles 1SNA 291 109 R0200
BJDL5.10	V0 10 poles 1SNA 291 110 R2600
BO3	10 x 3 mm 1SNA 164 406 R2400
SFB1	0,5 to 35 mm ² - H = 7 1SNA 163 860 R0500
SFB2	16 to 35 mm ² - H = 3 1SNA 168 956 R0600

(1) Entelec's spring terminal blocks with 5 mm spacing are compliant with IEC 947-1 standard for 2.5 mm² wire size. However, terminal blocks can also be connected to 4 mm² rigid wires.
 (2) Phase to phase = 400 V - Phase to ground = 250 V
 (3) Phase to phase = 6 kV - Phase to ground = 4 kV

(4) 200 mm max. (40 blocks) between 2 SPBO.NT.L

Interruptible neutral : Why ?

Example : fault on a TN-S network (1 neutral cable, 1 ground cable, both connected at the transformer)

Fault ① : fault between one phase and the device (e.g. industrial oven) frame
 It is a direct phase to ground fault. The fuse operates and the fault is identified.

Fault ② : fault limited by the load impedance - use of neutral interruptible function
 In this case, there is no direct phase to ground short-circuit and the fuse will not operate. There is a fault current on the ground path limited by the load impedance. Despite the apparent correct operation of the device, there is a potential danger for the users.

- Test procedure for fault location :**
- 1- Isolate the power transformer from the installation by operating the main disconnect switch.
 - 2- Insert an ohmmeter between neutral and ground before the distribution point to the different devices (as it is not possible to detect the origin of the fault if several devices are connected on the same circuit.
 - 3- Open the interruptible neutral levers one by one.
 - 4- When the faulty circuit is opened, the ohmmeter shows an infinite impedance. The fault is then identified.

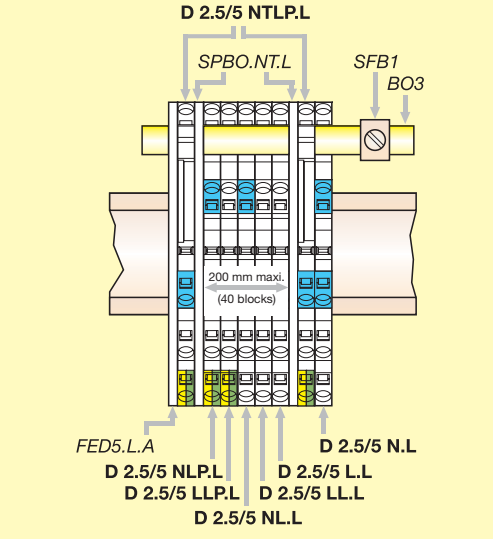
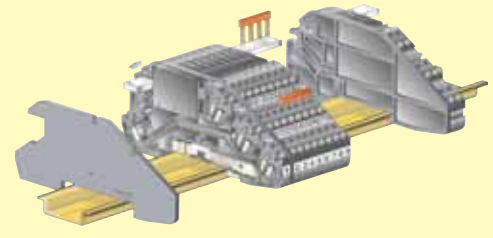
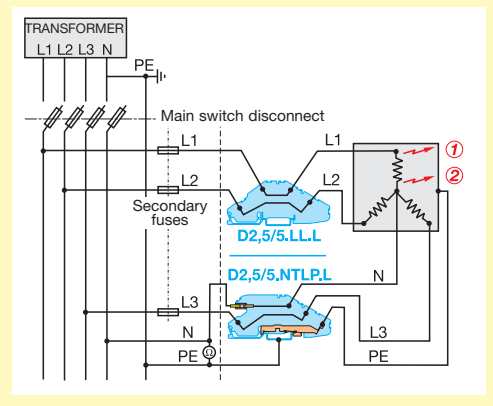

Terminal blocks spring clamp

for distribution boxes

DIN 3

Product range compatible with neutral busbar



End stop		th. 9 mm	BADL	V0	1SNA 399 903 R0200
End stop		th. 10 mm	BAM2 V0	V0	1SNA 399 967 R0100
End stop		th. 12 mm	BADH	V2	1SNA 116 900 R2700
End stop		th. 9,1 mm	BAMH	V2	1SNA 114 836 R0000
End stop		th. 9,1 mm	BAMH V0	V0	1SNA 194 836 R0100
Rail		35 x 7,5 x 1	PR3.Z2		1SNA 174 300 R1700
Rail		35 x 15 x 2,3	PR4		1SNA 168 500 R1200
Rail		35 x 15 x 1,5	PR5		1SNA 168 700 R2200

Other end stops, rails and accessories : see section on accessories.

Notes

The use of some accessories may decrease the block's voltage rating. For more information, consult us.

- * Blue marking on "neutral" circuit.
- Yellow/green marking on "ground" circuit.

One wire per spring.
UL 94 V0 material.

Accessories

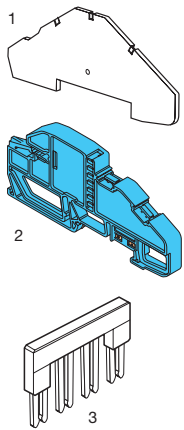

- End section grey
- Neutral bar end section holder (4)
- Jumper bar orange IP 20 - 24 A



R See section on markers marking method

D 2,5/5.NLP.L

Spacing 5 mm +0,05 .198"

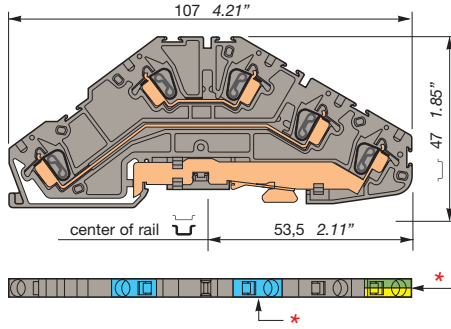

Colour	Type	Part number
1 circuit : "neutral"		
1 circuit : "feed-through"		
1 circuit : "ground" connected to the rail		
Grey V0		D 2,5/5.NLP.L 1SNA 290 324 R0300

Characteristics

Wire size	IEC		UL/CSA
	NFC	DIN	
Rigid	(1) 0,14-4 mm ²		26-12 AWG
Flexible	0,14-2,5 mm ²		26-12 AWG
Isolating cover			
Ground bar			
Voltage			
Rated		(2) 400 V / 250 V	300 V
Impulse withstand		(3) 6 kV / 4 kV	
Pollution degree		3	
Current			
Rated	Short circuit	24 A	300 A / 1s. 20 A
Wire size			
Rated / Gauge		2,5 mm ² / A2	12 AWG
Wire strip. length	Recomm. screwdriver	Weight	Protection
9,5 mm	3,5 mm	18 g	IP 20
.37"	.14"	.63 oz	NEMA 1

D 2,5/5.LLP.L

Spacing 5 mm +0,05 .198"

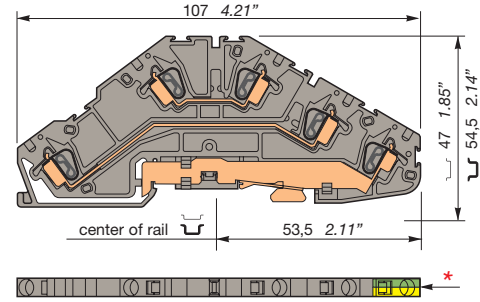

Colour	Type	Part number
2 circuits : "feed-through"		
1 circuit : "ground" connected to the rail		
Grey V0		D 2,5/5.LLP.L 1SNA 290 326 R0500

Characteristics

Wire size	IEC		UL/CSA
	NFC	DIN	
Rigid	(1) 0,14-4 mm ²		26-12 AWG
Flexible	0,14-2,5 mm ²		26-12 AWG
Isolating cover			
Ground bar			
Voltage			
Rated		(2) 400 V / 250 V	300 V
Impulse withstand		(3) 6 kV / 4 kV	
Pollution degree		3	
Current			
Rated	Short circuit	24 A	300 A / 1s. 20 A
Wire size			
Rated / Gauge		2,5 mm ² / A2	12 AWG
Wire strip. length	Recomm. screwdriver	Weight	Protection
9,5 mm	3,5 mm	18 g	IP 20
.37"	.14"	.63 oz	NEMA 1

Type	Part numbers
FED5.L.B V0 th. 2,5 mm	1SNA 291 560 R0100
SPBO.NT.L V0	1SNA 399 886 R2100
BJDL5.2 V0 2 poles	1SNA 291 102 R2300
BJDL5.3 V0 3 poles	1SNA 291 103 R2400
BJDL5.4 V0 4 poles	1SNA 291 104 R2500
BJDL5.5 V0 5 poles	1SNA 291 105 R2600
BJDL5.6 V0 6 poles	1SNA 291 106 R2700
BJDL5.7 V0 7 poles	1SNA 291 107 R2000
BJDL5.8 V0 8 poles	1SNA 291 108 R0100
BJDL5.9 V0 9 poles	1SNA 291 109 R0200
BJDL5.10 V0 10 poles	1SNA 291 110 R2600

- Entelec's spring terminal blocks with 5 mm spacing are compliant with IEC 947-1 standard for 2.5 mm² wire size. However, terminal blocks can also be connected to 4 mm² rigid wires.
- Phase to phase = 400 V - Phase to ground = 250 V
- Phase to phase = 6 kV - Phase to ground = 4 kV

Type	Part numbers
FED5.L.B V0 th. 2,5 mm	1SNA 291 560 R0100
SPBO.NT.L V0	1SNA 399 886 R2100
BJDL5.2 V0 2 poles	1SNA 291 102 R2300
BJDL5.3 V0 3 poles	1SNA 291 103 R2400
BJDL5.4 V0 4 poles	1SNA 291 104 R2500
BJDL5.5 V0 5 poles	1SNA 291 105 R2600
BJDL5.6 V0 6 poles	1SNA 291 106 R2700
BJDL5.7 V0 7 poles	1SNA 291 107 R2000
BJDL5.8 V0 8 poles	1SNA 291 108 R0100
BJDL5.9 V0 9 poles	1SNA 291 109 R0200
BJDL5.10 V0 10 poles	1SNA 291 110 R2600

- Entelec's spring terminal blocks with 5 mm spacing are compliant with IEC 947-1 standard for 2.5 mm² wire size. However, terminal blocks can also be connected to 4 mm² rigid wires.
- Phase to phase = 400 V - Phase to ground = 250 V
- Phase to phase = 6 kV - Phase to ground = 4 kV

RC55

(4) 200 mm max. between 2 SPBO.NT.L

RC55

Terminal blocks spring clamp

for distribution boxes

DIN 3

Product range compatible with neutral busbar



End stop		th. 9 mm	BADL	V0	1SNA 399 903 R0200
End stop		th. 10 mm	BAM2 V0	V0	1SNA 399 967 R0100
End stop		th. 12 mm	BADH	V2	1SNA 116 900 R2700
End stop		th. 9,1 mm	BAMH	V2	1SNA 114 836 R0000
End stop		th. 9,1 mm	BAMH V0	V0	1SNA 194 836 R0100
Rail		35 x 7,5 x 1	PR3.Z2		1SNA 174 300 R1700
Rail		35 x 15 x 2,3	PR4		1SNA 168 500 R1200
Rail		35 x 15 x 1,5	PR5		1SNA 168 700 R2200

Other end stops, rails and accessories : see section on accessories.

Notes

The use of some accessories may decrease the block's voltage rating. For more information, consult us.

* Blue marking on "neutral" circuit.

One wire per spring.
UL 94 V0 material.

Accessories

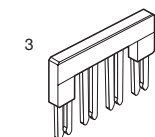
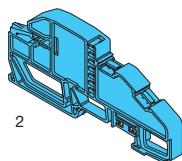
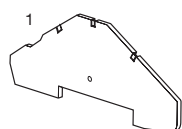

- 1 End section grey
- 2 Neutral bar end section holder (4)
- 3 Jumper bar orange IP 20 - 24 A

R See section on markers marking method

D 2,5/5.NL.L

Spacing 5 mm +0,05 .198"

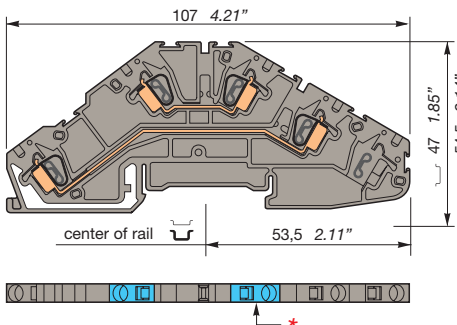

Colour	Type	Part number
1 circuit : "neutral"		
1 circuit : "feed-through"		
Grey V0	D 2,5/5.NL.L	1SNA 290 330 R1500

Characteristics

Wire size	IEC		UL/CSA
	NFC	DIN	
Rigid	(1) 0,14-4 mm ²		26-12 AWG
Flexible	0,14-2,5 mm ²		26-12 AWG
Isolating cover			
Ground bar			

Voltage		
Rated	400 V	300 V
Impulse withstand	6 kV	
Pollution degree	3	

Current		
Rated	24 A	20 A

Wire size			
Rated / Gauge	2,5 mm ² / A2	12 AWG	
Wire strip. length	Recomm. screwdriver	Weight	Protection
9,5 mm .37"	3,5 mm .14"	14 g .49 oz	IP 20 NEMA 1

Type	Part numbers
FED5.L.B V0	th. 2,5 mm 1SNA 291 560 R0100
SPBO.NT.LV0	1SNA 399 886 R2100
BJDL5.2 V0	2 poles 1SNA 291 102 R2300
BJDL5.3 V0	3 poles 1SNA 291 103 R2400
BJDL5.4 V0	4 poles 1SNA 291 104 R2500
BJDL5.5 V0	5 poles 1SNA 291 105 R2600
BJDL5.6 V0	6 poles 1SNA 291 106 R2700
BJDL5.7 V0	7 poles 1SNA 291 107 R2000
BJDL5.8 V0	8 poles 1SNA 291 108 R0100
BJDL5.9 V0	9 poles 1SNA 291 109 R0200
BJDL5.10 V0	10 poles 1SNA 291 110 R2600

(1) Entrelac's spring terminal blocks with 5 mm spacing are compliant with IEC 947-1 standard for 2.5 mm² wire size. However, terminal blocks can also be connected to 4 mm² rigid wires.

RC55

(4) 200 mm max. between 2 SPBO.NT.L

D 2,5/5.LL.L

Spacing 5 mm +0,05 .198"

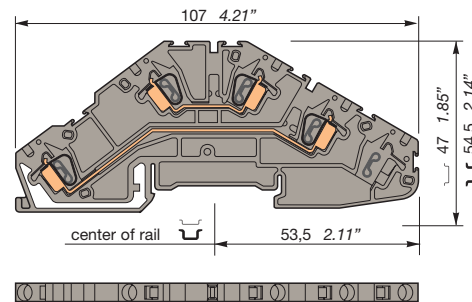

Colour	Type	Part number
2 circuits : "feed-through"		
Grey V0	D 2,5/5.LL.L	1SNA 290 328 R1700

Characteristics

Wire size	IEC		UL/CSA
	NFC	DIN	
Rigid	(1) 0,14-4 mm ²		26-12 AWG
Flexible	0,14-2,5 mm ²		26-12 AWG
Isolating cover			
Ground bar			

Voltage		
Rated	400 V	300 V
Impulse withstand	6 kV	
Pollution degree	3	

Current		
Rated	24 A	20 A

Wire size			
Rated / Gauge	2,5 mm ² / A2	12 AWG	
Wire strip. length	Recomm. screwdriver	Weight	Protection
9,5 mm .37"	3,5 mm .14"	14 g .49 oz	IP 20 NEMA 1

Type	Part numbers
FED5.L.B V0	th. 2,5 mm 1SNA 291 560 R0100
SPBO.NT.LV0	1SNA 399 886 R2100
BJDL5.2 V0	2 poles 1SNA 291 102 R2300
BJDL5.3 V0	3 poles 1SNA 291 103 R2400
BJDL5.4 V0	4 poles 1SNA 291 104 R2500
BJDL5.5 V0	5 poles 1SNA 291 105 R2600
BJDL5.6 V0	6 poles 1SNA 291 106 R2700
BJDL5.7 V0	7 poles 1SNA 291 107 R2000
BJDL5.8 V0	8 poles 1SNA 291 108 R0100
BJDL5.9 V0	9 poles 1SNA 291 109 R0200
BJDL5.10 V0	10 poles 1SNA 291 110 R2600

(1) Entrelac's spring terminal blocks with 5 mm spacing are compliant with IEC 947-1 standard for 2.5 mm² wire size. However, terminal blocks can also be connected to 4 mm² rigid wires.

RC55

